

RYOBI®

RAG750-115
RAG800-115
RAG800-125

ORIGINAL INSTRUCTIONS

Angle Grinder



Important!

It is essential that you read the instructions in this manual before assembling, operating, and maintaining the product.

Subject to technical modification.

Safety, performance, and dependability have been given top priority in the design of your angle grinder.

INTENDED USE

The angle grinder is intended to be used only by adults who have read and understood the instructions and warnings in this manual and can be considered responsible for their actions. The angle grinder is designed for grinding and cutting metals only. Only appropriate grinding discs as described in the product specification section of this manual should be fitted to the angle grinder. The angle grinder is designed for handheld use; it is not to be mounted onto a fixture or workbench.

GENERAL POWER TOOL SAFETY WARNINGS

WARNING

Read all safety warnings and all instructions. Failure to follow the warnings and instructions may result in electric shock, fire and/or serious injury.

Save all warnings and instructions for future reference.

The term "power tool" in the warnings refers to your mains-operated (corded) power tool or battery-operated (cordless) power tool.

1) WORK AREA SAFETY

- a) **Keep work area clean and well lit.** Cluttered or dark areas invite accidents.
- b) **Do not operate power tools in explosive atmospheres, such as in the presence of flammable liquids, gases or dust.** Power tools create sparks which may ignite the dust or fumes.
- c) **Keep children and bystanders away while operating a power tool.** Distractions can cause you to lose control.

2) ELECTRICAL SAFETY

- a) **Power tool plugs must match the outlet. Never modify the plug in any way. Do not use any adapter plugs with earthed (grounded) power tools.** Unmodified plugs and matching outlets will reduce risk of electric shock.
- b) **Avoid body contact with earthed or grounded surfaces, such as pipes, radiators, ranges and refrigerators.** There is an increased risk of electric shock if your body is earthed or grounded.
- c) **Do not expose power tools to rain or wet conditions.** Water entering a power tool will increase the risk of electric shock.
- d) **Do not abuse the cord. Never use the cord for carrying, pulling or unplugging the power tool. Keep cord away from heat, oil, sharp edges or moving parts.** Damaged or entangled cords increase the risk of electric shock.
- e) **When operating a power tool outdoors, use an extension cord suitable for outdoor use.** Use of a cord suitable for outdoor use reduces the risk of electric shock.
- f) **If operating a power tool in a damp location is unavoidable, use a residual current device (RCD) protected supply.** Use of an RCD reduces

the risk of electric shock.

3) PERSONAL SAFETY

- a) **Stay alert, watch what you are doing and use common sense when operating a power tool. Do not use a power tool while you are tired or under the influence of drugs, alcohol or medication.** A moment of inattention while operating power tools may result in serious personal injury.
- b) **Use personal protective equipment. Always wear eye protection.** Protective equipment such as dust mask, non-skid safety shoes, hard hat or hearing protection used for appropriate conditions will reduce personal injuries.
- c) **Prevent unintentional starting. Ensure the switch is in the off-position before connecting to power source and/or battery pack, picking up or carrying the tool.** Carrying power tools with your finger on the switch or energising power tools that have the switch on invites accidents.
- d) **Remove any adjusting key or wrench before turning the power tool on.** A wrench or a key left attached to a rotating part of the power tool may result in personal injury.
- e) **Do not overreach. Keep proper footing and balance at all times.** This enables better control of the power tool in unexpected situations.
- f) **Dress properly. Do not wear loose clothing or jewellery. Keep your hair, clothing and gloves away from moving parts.** Loose clothes, jewellery or long hair can be caught in moving parts.
- g) **If devices are provided for the connection of dust extraction and collection facilities, ensure these are connected and properly used.** Use of dust collection can reduce dust-related hazards.

4) POWER TOOL USE AND CARE

- a) **Do not force the power tool. Use the correct power tool for your application.** The correct power tool will do the job better and safer at the rate for which it was designed.
- b) **Do not use the power tool if the switch does not turn it on and off.** Any power tool that cannot be controlled with the switch is dangerous and must be repaired.
- c) **Disconnect the plug from the power source and/or the battery pack from the power tool before making any adjustments, changing accessories or storing power tools.** Such preventive safety measures reduce the risk of starting the power tool accidentally.
- d) **Store idle power tools out of the reach of children and do not allow persons unfamiliar with the power tool or these instructions to operate the power tool.** Power tools are dangerous in the hands of untrained users.
- e) **Maintain power tools. Check for misalignment or binding of moving parts, breakage of parts and any other condition that may affect the power tool's operation. If damaged, have the power tool repaired before use.** Many accidents are caused by poorly maintained power tools.
- f) **Keep cutting tools sharp and clean.** Properly

maintained cutting tools with sharp cutting edges are less likely to bind and are easier to control.

- g) **Use the power tool, accessories and tool bits etc, in accordance with these instructions, taking into account the working conditions and the work to be performed.** Use of the power tool for operations different from those intended could result in a hazardous situation.

SERVICE

Have your power tool serviced by a qualified repair person using only identical replacement parts. This will ensure that the safety of the power tool is maintained.

ANGLE GRINDER SAFETY WARNINGS

SAFETY WARNINGS COMMON FOR GRINDING OR ABRASIVE CUTTING-OFF OPERATIONS:

- a) **This power tool is intended to function as a grinder or cut-off tool. Read all safety warnings, instructions, illustrations and specifications provided with this power tool.** Failure to follow all instructions listed below may result in electric shock, fire and/or serious injury.
- b) **Operations such as sanding, wire brushing or polishing are not recommended to be performed with this power tool.** Operations for which the power tool was not designed may create a hazard and cause personal injury.
- c) **Do not use accessories which are not specifically designed and recommended by the tool manufacturer.** Just because the accessory can be attached to your power tool does not assure safe operation.
- d) **The rated speed of the accessory must be at least equal to the maximum speed marked on the power tool.** Accessories running faster than their rated speed can break and fly apart.
- e) **The outside diameter and the thickness of your accessory must be within the capacity rating of your power tool.** Incorrectly sized accessories cannot be adequately guarded or controlled.
- f) **Threaded mounting of accessories must match the grinder spindle thread. For accessories mounted by flanges, the arbour hole of the accessory must fit the locating diameter of the flange.** Accessories that do not match the mounting hardware of the power tool will run out of balance, vibrate excessively and may cause loss of control.
- g) **Do not use a damaged accessory. Before each use inspect the accessory such as abrasive wheels for chips and cracks, backing pad for cracks, tear or excess wear, wire brush for loose or cracked wires. If power tool or accessory is dropped, inspect for damage or install an undamaged accessory. After inspecting and installing an accessory, position yourself and bystanders away from the plane of the rotating accessory and run the power tool at maximum no-load speed for one minute.** Damaged accessories will normally break apart during this test time.
- h) **Wear personal protective equipment. Depending on application, use face shield, safety goggles or safety glasses.**

As appropriate, wear dust mask, hearing protectors, gloves and workshop apron capable of stopping small abrasive or workpiece fragments. The eye protection must be capable of stopping flying debris generated by various operations. The dust mask or respirator must be capable of filtrating particles generated by your operation. Prolonged exposure to high intensity noise may cause hearing loss.

- i) **Keep bystanders a safe distance away from work area. Anyone entering the work area must wear personal protective equipment.** Fragments of workpiece or of a broken accessory may fly away and cause injury beyond immediate area of operation.
- j) **Hold the power tool by insulated gripping surfaces only, when performing an operation where the cutting accessory may contact hidden wiring or its own cord.** Cutting accessory contacting a "live" wire may make exposed metal parts of the power tool "live" and could give the operator an electric shock.
- k) **Position the cord clear of the spinning accessory.** If you lose control, the cord may be cut or snagged and your hand or arm may be pulled into the spinning accessory.
- l) **Never lay the power tool down until the accessory has come to a complete stop.** The spinning accessory may grab the surface and pull the power tool out of your control.
- m) **Do not run the power tool while carrying it at your side.** Accidental contact with the spinning accessory could snag your clothing, pulling the accessory into your body.
- n) **Regularly clean the power tool's air vents.** The motor's fan will draw the dust inside the housing and excessive accumulation of powdered metal may cause electrical hazards.
- o) **Do not operate the power tool near flammable materials.** Sparks could ignite these materials.
- p) **Do not use accessories that require liquid coolants.** Using water or other liquid coolants may result in electrocution or shock.

FURTHER SAFETY INSTRUCTIONS FOR ALL OPERATIONS

Kickback and related warnings

Kickback is a sudden reaction to a pinched or snagged rotating wheel, backing pad, brush or any other accessory. Pinching or snagging causes rapid stalling of the rotating accessory, which in turn causes the uncontrolled power tool to be forced in the direction opposite of the accessory's rotation at the point of the binding.

For example, if an abrasive wheel is snagged or pinched by the workpiece, the edge of the wheel that is entering into the pinch point can dig into the surface of the material causing the wheel to climb out or kick out. The wheel may either jump toward or away from the operator, depending on the direction of the wheel's movement at the point of pinching. Abrasive wheels may also break under these conditions.

Kickback is the result of power tool misuse and/or incorrect operating procedures or conditions and can be avoided by taking proper precautions as given below.

- a) **Maintain a firm grip on the power tool and**

position your body and arm to allow you to resist kickback forces. Always use auxiliary handle, if provided, for maximum control over kickback or torque reaction during start-up. The operator can control torque reactions or kickback forces, if proper precautions are taken.

- b) **Never place your hand near the rotating accessory.** Accessory may kickback over your hand.
- c) **Do not position your body in the area where power tool will move if kickback occurs.** Kickback will propel the tool in direction opposite to the wheel's movement at the point of snagging.
- d) **Use special care when working corners, sharp edges, etc. Avoid bouncing and snagging the accessory.** Corners, sharp edges or bouncing have a tendency to snag the rotating accessory and cause loss of control or kickback.
- e) **Do not attach a saw chain woodcarving blade or toothed saw blade.** Such blades create frequent kickback and loss of control.

ADDITIONAL SAFETY INSTRUCTIONS FOR GRINDING AND CUTTING-OFF OPERATIONS

Safety warnings specific for grinding and abrasive cutting-off operations:

- a) **Use only wheel types that are recommended for your power tool and the specific guard designed for the selected wheel.** Wheels for which the power tool was not designed cannot be adequately guarded and are unsafe.
- b) **The grinding surface of centre depressed wheels must be mounted below the plane of the guard lip.** An improperly mounted wheel that projects through the plane of the guard lip cannot be adequately protected.
- c) **The guard must be securely attached to the power tool and positioned for maximum safety, so the least amount of wheel is exposed towards the operator.** The guard helps to protect the operator from broken wheel fragments, accidental contact with wheel and sparks that could ignite clothing.
- d) **Wheels must be used only for recommended applications. For example: Do not grind with the side of cut-off wheel.** Abrasive cut-off wheels are intended for peripheral grinding, side forces applied to these wheels may cause them to shatter.
- e) **Always use undamaged wheel flanges that are of correct size and shape for your selected wheel.** Proper wheel flanges support the wheel, thus reducing the possibility of wheel breakage. Flanges for cut-off wheels may be different from grinding wheel flanges.
- f) **Do not use worn down wheels from larger power tools.** Wheel intended for larger power tool is not suitable for the higher speed of a smaller tool and may burst.

ADDITIONAL SAFETY WARNINGS SPECIFIC FOR ABRASIVE CUTTING-OFF OPERATIONS

- a) **Do not "jam" the cut-off wheel or apply excessive pressure. Do not attempt to make an excessive depth of cut.** Overstressing the wheel increases the loading and susceptibility to twisting

or binding of the wheel in the cut and the possibility of kickback or wheel breakage.

- b) **Do not position your body in line with and behind the rotating wheel.** When the wheel, at the point of operation, is moving away from your body, the possible kickback may propel the spinning wheel and the power tool directly at you.
- c) **When wheel is binding or when interrupting a cut for any reason, switch off the power tool and hold the power tool motionless until the wheel comes to a complete stop. Never attempt to remove the cut-off wheel from the cut while the wheel is in motion otherwise kickback may occur.** Investigate and take corrective action to eliminate the cause of wheel binding.
- d) **Do not restart the cutting operation in the workpiece.** Let the wheel reach full speed and carefully re-enter the cut. The wheel may bind, walk up or kickback if the power tool is restarted in the workpiece.
- e) **Support panels or any oversized workpiece to minimize the risk of wheel pinching and kickback.** Large workpieces tend to sag under their own weight. Supports must be placed under the workpiece near the line of cut and near the edge of the workpiece on both sides of the wheel.
- f) **Use extra caution when making a "pocket cut" into existing walls or other blind areas.** The protruding wheel may cut gas or water pipes, electrical wiring or objects that can cause kickback.

ANGLE GRINDER SAFETY PRECAUTIONS

- a) Check that the speed marked on the grinding wheel is equal to or greater than the rated speed of the product.
- b) Ensure that the dimensions of the grinding wheel are compatible with the product and that the wheel fits the spindle.
- c) Grinding wheels must be stored in a dry place.
- d) Do not store objects on top of the grinding wheels.
- e) Grinding wheels must not be used for any operation other than grinding.
- f) Grinding wheels must be stored and handled with care in accordance with the manufacturer's instruction.
- g) Inspect the grinding wheel before use to ensure that it is not chipped or cracked. Chips or cracks can cause the wheels to shatter, resulting in possible serious injury.
- h) Ensure that the wheel is fitted in accordance with this manual.
- i) Ensure that the grinding wheel is correctly mounted and tightened before use and run the product at no-load speed for 30 seconds in a safe position. Stop immediately if there is considerable vibration or if other defects are detected. If this condition occurs, check the tool to determine the cause.
- j) Do not use separate reducing bushings or adapters to adapt large hole grinding wheels.
- k) Check that the workpiece is properly supported.
- l) Use only grinding wheels approved by RYOBI.

- m) Ensure that sparks resulting from use do not create a hazard, e.g., do not hit people, or ignite flammable substances.
- n) Always use protective safety glasses and ear protectors.
- o) Use other personal protective equipment, such as gloves, apron, and helmet, when necessary.
- p) Never place the product on the floor or other surfaces while it is running. Grinding wheels continue to rotate after the product is switched off. Never touch the wheel or place it on the floor or other surfaces while it is rotating.
- q) Use the product only for approved applications. Never use coolants or water or use the tool as a fixed tool.
- r) Grip the product securely with both hands while operating.

RESIDUAL RISKS

Even when the angle grinder is used as prescribed, it is still impossible to completely eliminate certain residual risk factors. The following hazards may arise and the operator should pay special attention to avoid the following:

- Injury caused by thrown-off particles
 - Metal or abrasive particles may enter the eyes and cause severe permanent damage. Wear goggles approved for grinding operations when operating the product.
- Injury caused by vibration
 - Limit exposure. See Risk Reduction.
- Injury caused by dust
 - Wear appropriate dust control mask with filters suitable for protecting against particles from the material being worked on and abrasive particles from the grinding disc. Do not eat, drink, or smoke in the work area. Ensure adequate ventilation.
- Injury from contact with the grinding disc
 - The disc and workpiece will become hot during use. Wear gloves when changing discs or touching workpiece. Keep hands away from the grinding area at all times. Clamp the workpiece whenever possible.
- Injury caused by noise
 - Prolonged exposure to noise will increase the risk of hearing damage, and the effects are cumulative. When using power tools for an extended period of time, wear hearing protection.

RISK REDUCTION

It has been reported that vibrations from handheld tools may contribute to a condition called Raynaud's Syndrome in certain individuals. Symptoms may include tingling, numbness and blanching of the fingers, usually apparent upon exposure to cold. Hereditary factors, exposure to cold and dampness, diet, smoking, and work practices are all thought to contribute to the development of these symptoms. There are measures that can be taken by the operator to possibly reduce the effects of vibration:

- Keep your body warm in cold weather. When operating the product, wear gloves to keep the hands and wrists warm. It is reported that cold weather is a major factor contributing to Raynaud's Syndrome.

- After each period of operation, exercise to increase blood circulation.
- Take frequent work breaks. Limit the amount of exposure per day.

If you experience any of the symptoms of this condition, immediately discontinue use and see your doctor about these symptoms.

⚠ WARNING

Injuries may be caused or aggravated by prolonged use of a tool. When using any tool for prolonged periods, ensure you take regular breaks.

KNOW YOUR PRODUCT

See page 7.

1. Switch button
2. Spindle lock button
3. Guard lever lock
4. Grinding wheel
5. Clamp nut
6. Wheel guard assembly
7. Disc flange
8. Auxiliary handle
9. Wrench

STARTUP PROTECTION

Machines with a lock-on switch are fitted with a cut-out. This prevents the machine from restarting by itself after a power failure. When resuming work, switch the machine off and then switch it back on again.

MAINTENANCE

⚠ WARNING

Do not make any adjustments while the motor is in motion.

The product should never be connected to a power supply when assembling parts, making adjustments, cleaning, performing maintenance, or when the product is not in use. Disconnecting the product will prevent accidental starting that could cause serious injury.

- After use, check the product to make sure that it is in good condition.
- It is recommended that you take the product to a Ryobi authorised service centre for a thorough cleaning and lubrication at least once a year.
- If the power supply cord is damaged, it must be replaced only by the manufacturer or by an authorised service centre to avoid risk. Contact authorised service centre.

⚠ WARNING

To ensure safety and reliability, all repairs should be performed by an authorised service center or other qualified service organisation.

⚠ WARNING

Do not use compressed air to blow dust from the product. This practice is dangerous and can cause dirt and grit to be blasted into someone's eyes, causing serious injury.

ENVIRONMENTAL PROTECTION



Recycle raw materials instead of disposing of as waste. The machine, accessories and packaging should be sorted for environment-friendly recycling.

SYMBOLS ON THE PRODUCT



Safety Alert

V

Volts

Hz

Hertz

~

Alternating current

W

Watts

n

Rated speed

min⁻¹

Revolutions or reciprocations per minute



Class II tool, double insulation



Please read the instructions carefully before starting the product.



Wear ear protection



Wear eye protection



Wear dust mask.



Do not use chipped, cracked or defective grinding wheel



Not for wet grinding. Using water or other liquid coolants may result in electrocution or shock.



Wear safety hand gloves



Do not use for face grinding.



Wear safety footwear.



Wear eye and ear protection and mask



CE Conformity



EurAsian Conformity Mark.



Ukrainian mark of conformity.



Waste electrical products should not be disposed of with household waste. Please recycle where facilities exist. Check with your local authority or retailer for recycling advice.

SYMBOLS IN THIS MANUAL



Connect to the power supply.



Disconnect from the power supply.



Parts or accessories sold separately



Waste electrical products should not be disposed of with household waste. Please recycle where facilities exist.



Lock



Unlock



Note



Warning



Stop the product.

The following signal words and meanings are intended to explain the levels of risk associated with this product:

⚠ DANGER

Indicates an imminently hazardous situation, which, if not avoided, will result in death or serious injury.

⚠ WARNING

Indicates a potentially hazardous situation, which, if not avoided, could result in death or serious injury.

⚠ CAUTION

Indicates a potentially hazardous situation, which, if not avoided, may result in minor or moderate injury.

CAUTION

(Without Safety Alert Symbol) Indicates a situation that may result in property damage.



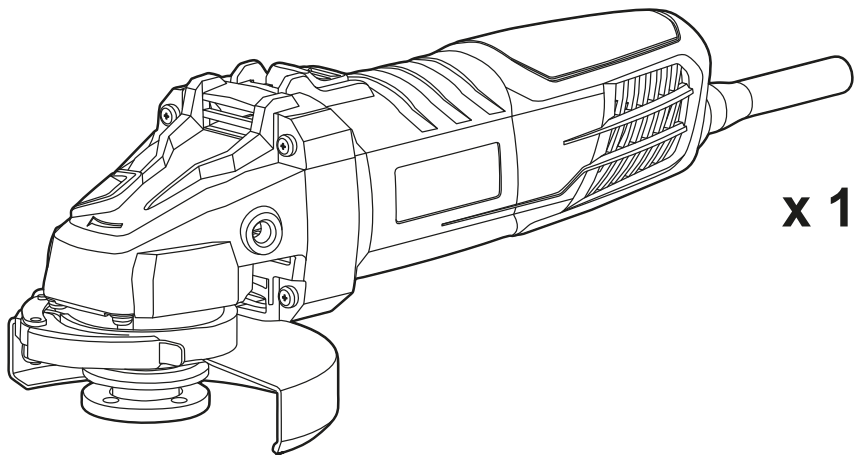

x 1

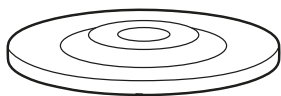

x 1

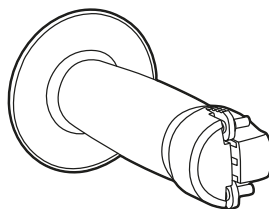

x 1

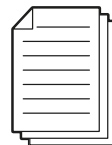

x 1

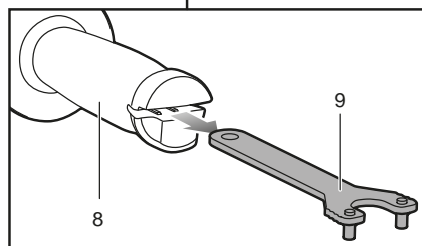
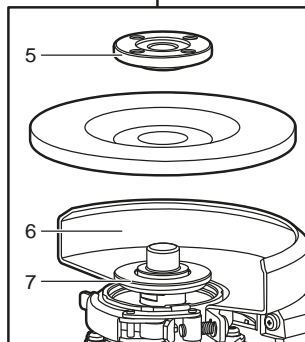
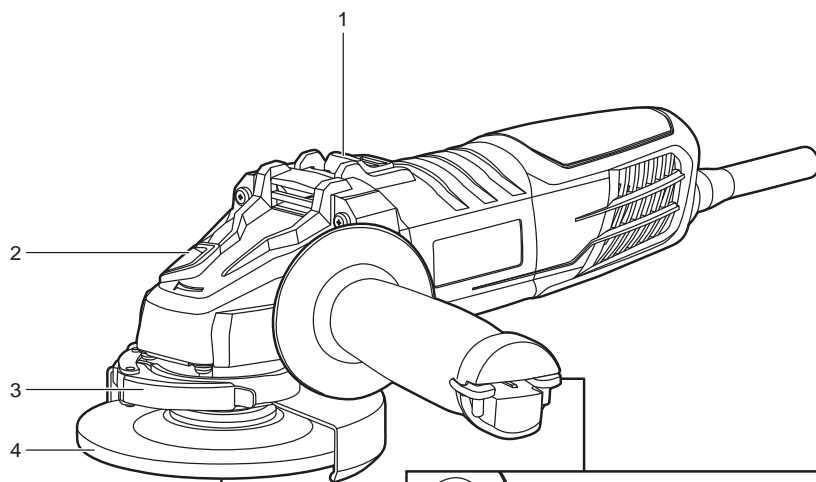

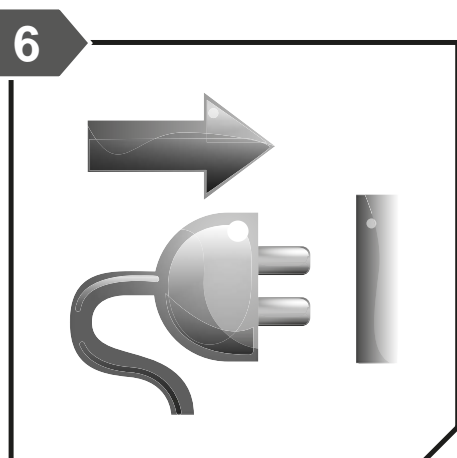
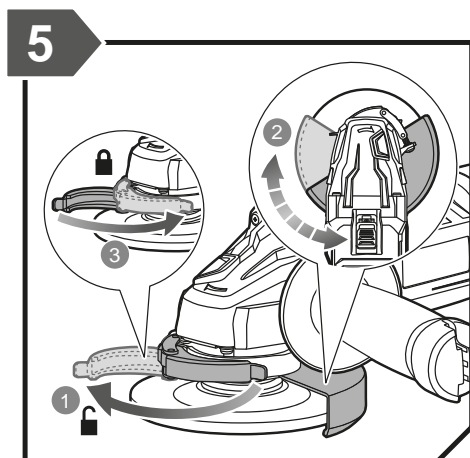
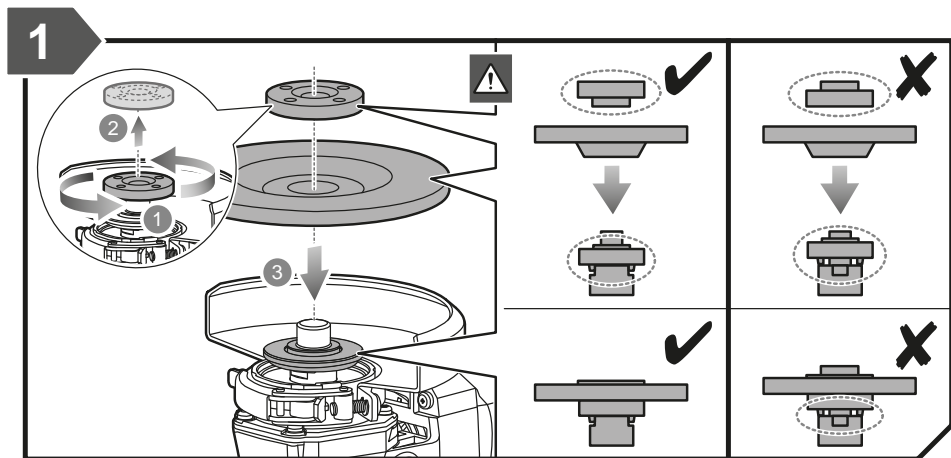

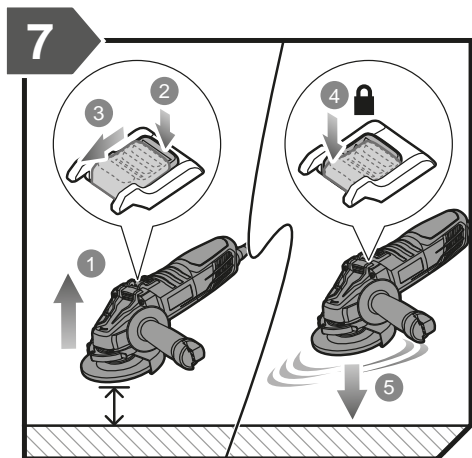
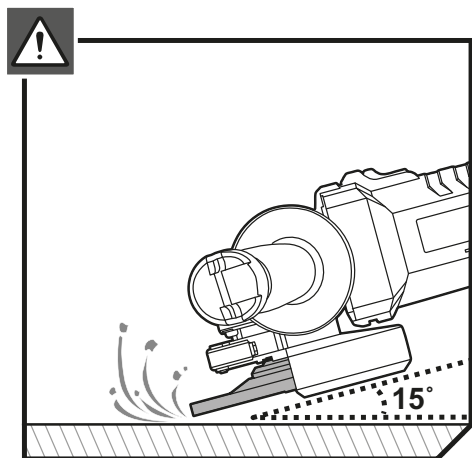
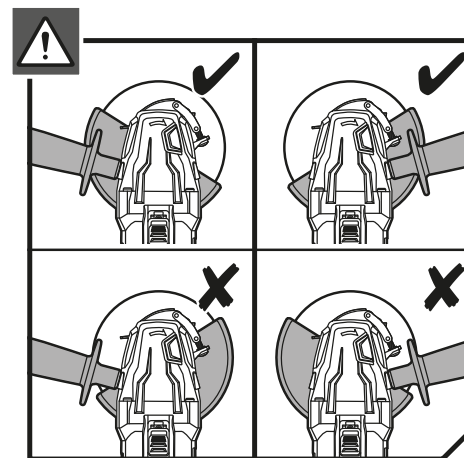
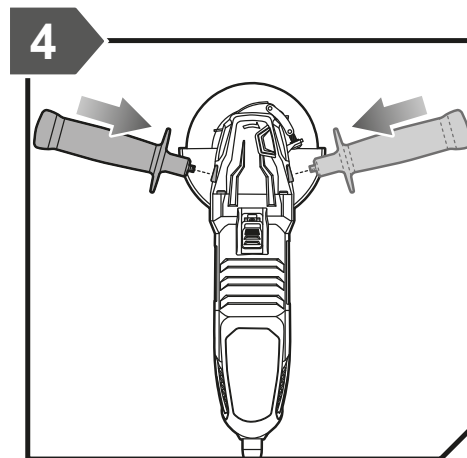
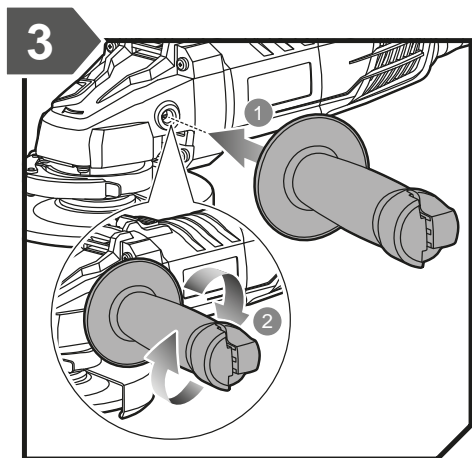
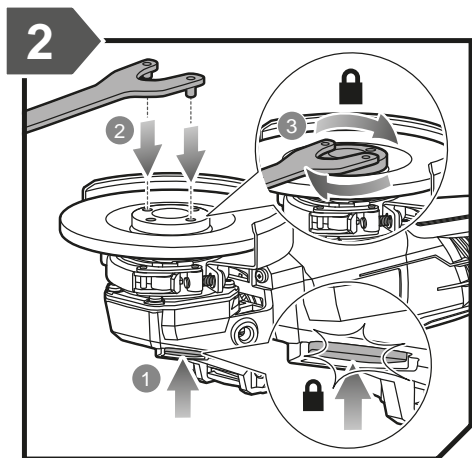

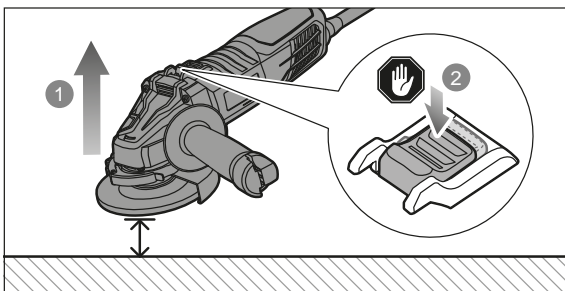
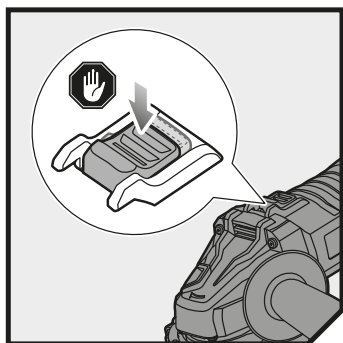
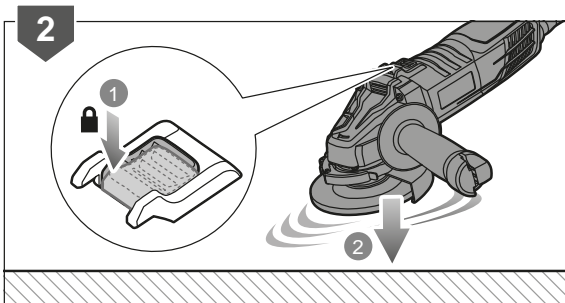
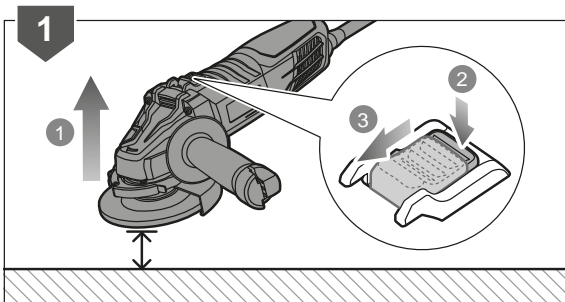
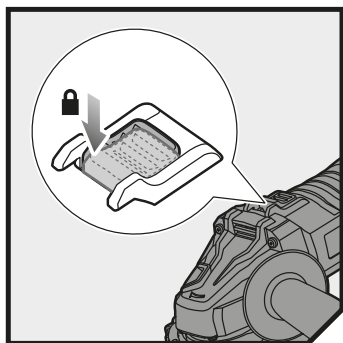

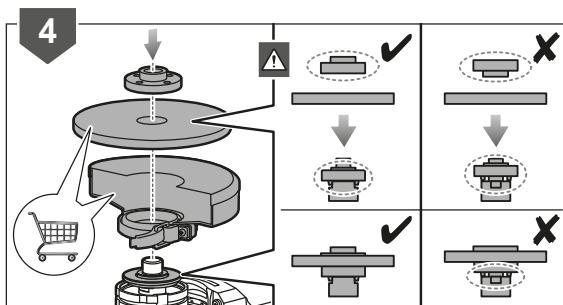
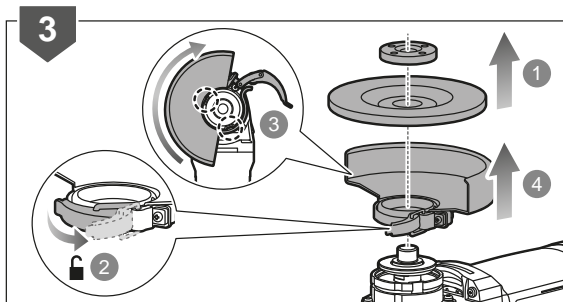
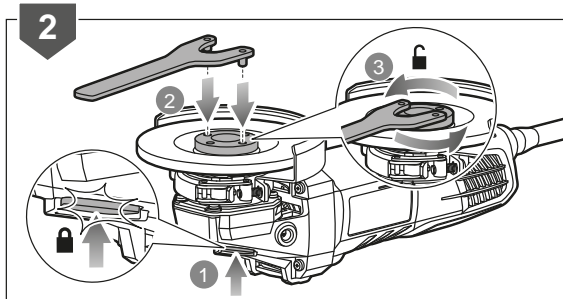
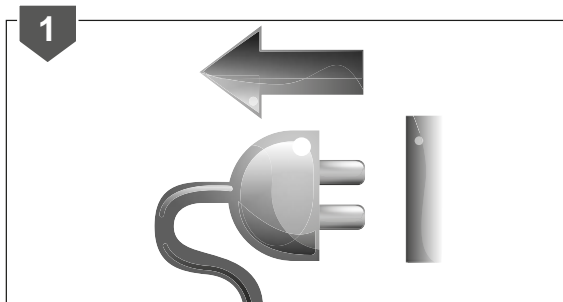
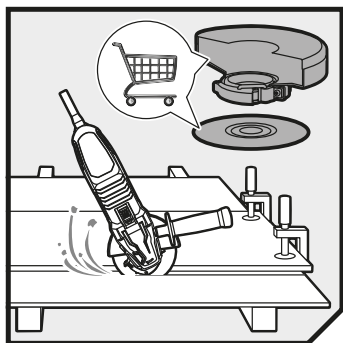

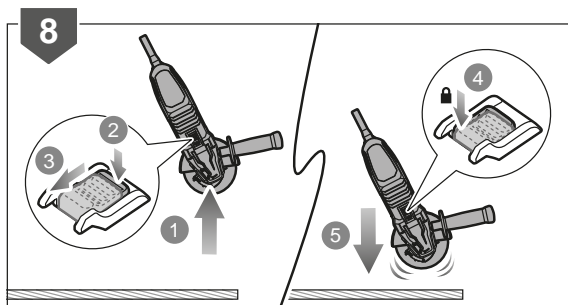
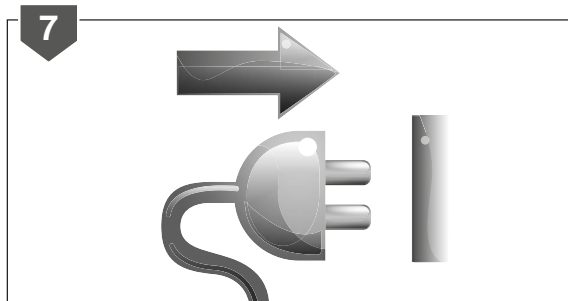
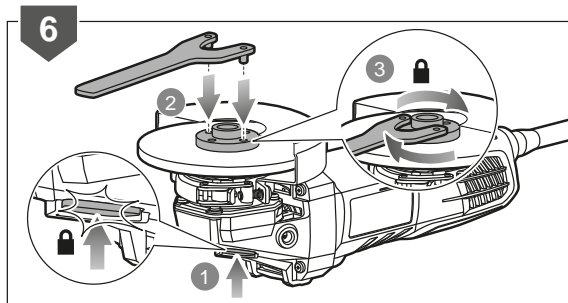
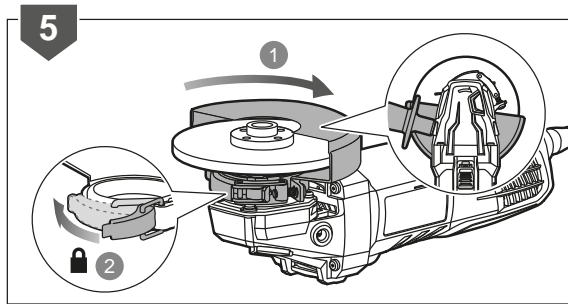

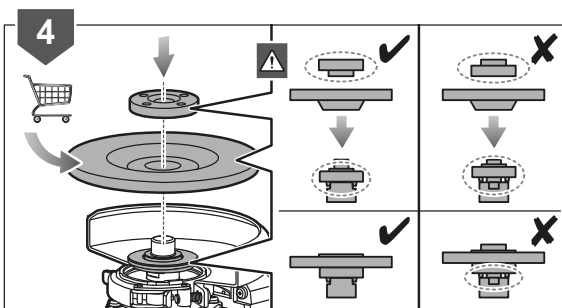
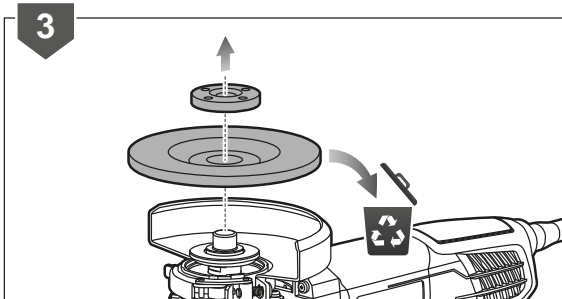
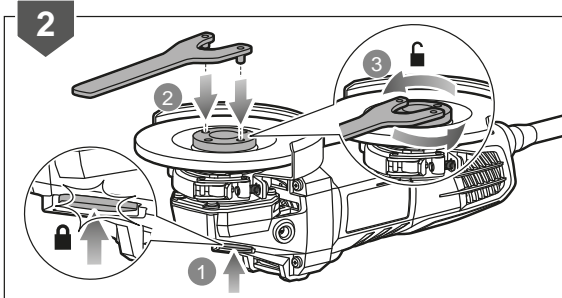
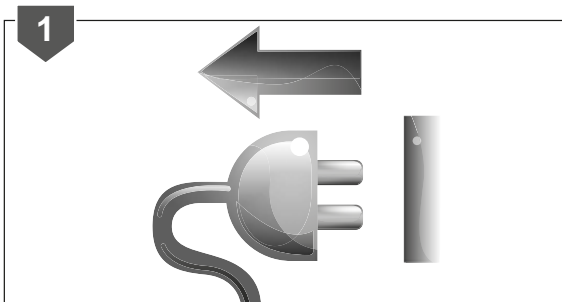
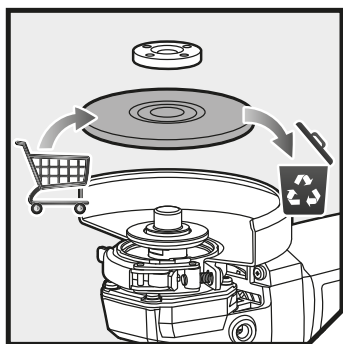

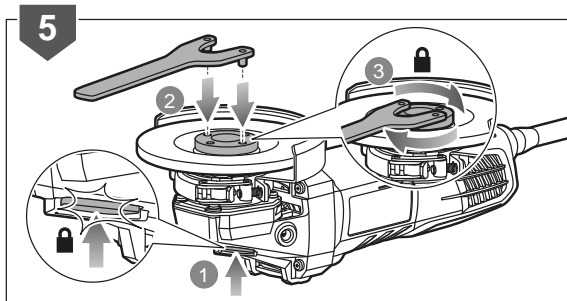

PRODUCT SPECIFICATIONS

Angle Grinder			
Model	RAG750-115	RAG800-115	RAG800-125
Grinding wheel:			
Diameter	115 mm (4.5 in.)	115 mm (4.5 in.)	125 mm (5 in.)
Thickness	6 mm	6 mm	6 mm
Cutting wheel:			
Diameter	115 mm (4.5 in.)	115 mm (4.5 in.)	125 mm (5 in.)
Thickness	3 mm	3 mm	3 mm
Diamond wheel:			
Diameter	115 mm (4.5 in.)	115 mm (4.5 in.)	125 mm (5 in.)
Thickness	2 mm	2 mm	2 mm
Rated voltage	220 - 240 V ~ 50 / 60 Hz	220 - 240 V ~ 50 / 60 Hz	220 - 240 V ~ 50 / 60 Hz
Rated capacity	115 mm	115 mm	125 mm
Input	750 W	800 W	800 W
Spindle thread	M 14	M 14	M 14
Rated speed	12000 min ⁻¹	12000 min ⁻¹	12000 min ⁻¹
Net weight	2.35 kg	2.35 kg	2.35 kg
Measured sound values determined according to EN 60745:			
A-weighted sound pressure level	$L_{PA} = 86.5$ dB(A)	$L_{PA} = 86.5$ dB(A)	$L_{PA} = 86.5$ dB(A)
Uncertainty K	3 dB	3 dB	3 dB
A-weighted sound power level	$L_{WA} = 97.5$ dB(A)	$L_{WA} = 97.5$ dB(A)	$L_{WA} = 97.5$ dB(A)
Uncertainty K	3 dB	3 dB	3 dB
The vibration total values (triaxial vector sum) determined according to EN 60745:			
Surface grinding, Vibration emission level	$a_{TAG} = 6.9$ m/s ²	$a_{TAG} = 6.9$ m/s ²	$a_{TAG} = 6.9$ m/s ²
Uncertainty K	1.5 m/s ²	1.5 m/s ²	1.5 m/s ²

VIBRATION LEVEL



WARNING

The vibration emission level given in this information sheet has been measured in accordance with a standardised test given in EN 60745 and may be used to compare one tool with another. It may be used for a preliminary assessment of exposure. The declared vibration emission level represents the main applications of the tool. However if the tool is used for different applications, with different accessories or poorly maintained, the vibration emission may differ. This may significantly increase the exposure level over the total working period.

An estimation of the level of exposure to vibration should also take into account the times when the tool is switched off or when it is running but not actually doing the job. This may significantly reduce the exposure level over the total working period. Identify additional safety measures to protect the operator from the effects of vibration such as: maintain the tool and the accessories, keep the hands warm, organisation of work patterns.

GUARANTEE

In addition to any statutory rights resulting from the purchase, this product is covered by a guarantee as stated below.

1. The guarantee period is 24 months for consumers and commences on the date when the product was purchased. This date has to be documented by an invoice or other proof of purchase. The product is designed and dedicated to consumer and private use only. So there is no guarantee provided in case of professional or commercial use.
2. There is, in some cases (i.e. promotion, range of tools), a possibility to extend the warranty period over the period described above using the registration on the www.ryobitools.eu website. The eligibility of the tool is clearly displayed in stores and/or on packaging. The end user needs to register his/her newly-acquired tools online within 8 days from the date of purchase. The end user may register for the extended warranty in his country of residence if listed on the online registration form where this option is valid. Furthermore, end users must give their consent to the storage of the data which are required to enter online and they have to accept the terms and conditions. The registration confirmation receipt, which is sent out by e-mail, and the original invoice showing the date of purchase will serve as proof of the extended warranty. Your statutory rights remain unaffected.
3. The guarantee covers all defects of the product during the warranty period due to defaults in workmanship or material at the purchase date. The guarantee is limited to repair and/or replacement and does not include any other obligations including but not limited to incidental or consequential damages. The warranty is not valid if the product has been misused, used contrary to the instruction manual, or being incorrectly connected. This guarantee does not apply to
 - any damage to the product that is the result of improper maintenance
 - any product that has been altered or modified
 - any product where original identification (trade mark, serial number) markings have been defaced, altered or removed
 - any damage caused by non-observance of the instruction manual
 - any non CE product
 - any product which has been attempted to be repaired by a non-qualified professional or without prior authorization by Techtronic Industries
 - any product connected to improper power supply (amps, voltage, frequency)
 - any damage caused by external influences (chemical, physical, shocks) or foreign substances
 - normal wear and tear of spare parts
 - inappropriate use, overloading of the tool
 - use of non-approved accessories or parts
 - carburettor after 6 months, carburettor adjustments after 6 months
 - power tool accessories provided with tool or purchased separately. Such exclusions include but is not limited to screw driver bits, drill bits, abrasive discs, sand paper and blades, lateral guide
 - components (parts and accessories) subject to natural wear and tear, including but not limited to carbon brushes, chuck, power cord, auxiliary handle, sanding plate, dust bag, dust exhaust tube
4. For servicing, the product must be sent or presented to a RYOBI authorized service station listed for each country in the following list of service station addresses. In some countries your local RYOBI dealer undertakes to send the product to the RYOBI service organisation. When sending a product to a RYOBI service station, the product should be safely packed without any dangerous contents such as petrol, marked with sender's address and accompanied by a short description of the fault.
5. A repair/replacement under this guarantee is free of charge. It does not constitute an extension or a new start of the guarantee period. Exchanged parts or tools become our property. In some countries delivery charges or postage will have to be paid by the sender.
6. This guarantee is valid in the European Community, Switzerland, Iceland, Norway, Liechtenstein, Turkey and Russia. Outside these areas, please contact your authorized RYOBI dealer to determine if another warranty applies.

AUTHORISED SERVICE CENTRES

ACD PLANT LTD
145 Southbank Road
Coundon
Coventry, West Midlands
CV6 1FG
Phone: 02476 594348
Email: danmcgunigle@acdplant.co.uk
Web: www.acdplant.co.uk

CBS Power Tools Limited
Unit 4, V P Square
Storeys Bar Rd, Fengate
Peterborough, Cambridgeshire
PE1 5YS
Phone: 01733 343031
Email: steve@cbspowertools.co.uk
Web: www.cbspowertools.com

C D Powertools
76 Old Road
Churwell Morley, Leeds
LS27 7TH
Phone: 0113 2718494
Email: info@cdpowertools.co.uk
Web: www.cdpowertools.co.uk

C J Sinclair Limited
44 Victoria Road
St Peters
Broadstairs, Kent
CT10 2UG
Phone: 01843 869400
Email: repairs@cjsinclairltd.co.uk
Web: www.cjsinclairltd.co.uk

Powertech Ind Ltd
Unit 2C, Ellison Road
Norwood Ind, Killamarsh
Sheffield, South Yorkshire
S21 2JG
Phone: 01142 474080
Email: stores@powertech-industrial.co.uk
Web: www.powertech-industrial.co.uk

RYCKO Technical Services LTD
104 Green Lane
St Albans, Herts
AL3 6EX
Phone: 08458 678790
Email: info@ryckotechnical.com
Web: www.ryckotechnical.com

ToolTech Industrial Equipment
227 E Dunhill Road, Macosquin
Coleraine, Co Londonderry
BT514LQ
Phone: 028 70359493
Email: john@tooltech.org.uk

For an updated list of authorised service centres, visit <http://uk.ryobitools.eu/header/service-and-support/service-agents>.

DECLARATION OF CONFORMITY

Techtronic Industries GmbH
Max-Eyth-Straße 10, 71364 Winnenden, Germany

Herewith we declare that the product

Angle Grinder
Brand: Ryobi
Model number: RAG750-115 / RAG800-115/ RAG800-125
Serial number range:
RAG750-115: 44453501000001- 44453501999999
RAG800-115: 44454101000001- 44454101999999
RAG800-125: 44460301000001- 44460301999999

is in conformity with the following European Directives and harmonised standards

2006/42/EC, 2004/108/EC (until 19 April 2016), 2014/30/EU, 2011/65/EU
EN55014-1:2006+A1:2009+A2:2011, EN55014-2:1997+A1:2001+A2:2008, EN61000-3-2:2014,
EN61000-3-3:2013, EN60745-1:2009+A11:2010, EN60745-2-3:2011+A2:2013+A11:2014+A12:2014

RoHS documentation is compiled according to EN 50581:2012

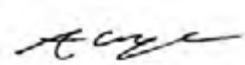

Andrew John Eyre (BEng, CEng, MIET)
Vice President, Regulatory & Safety
Winnenden, Oct. 20, 2015

Authorised to compile the technical file:
Alexander Krug, Managing Director
Techtronic Industries GmbH
Max-Eyth-Straße 10, 71364 Winnenden, Germany







Techtronic Industries GmbH
Max-Eyth-Straße 10,
71364 Winnenden, Germany

20151013v1