

# Ultrastar® DC HA210

(Previously known as Ultrastar 7K2)

Capacity Enterprise HDD

HUS722T2TALA604

HUS722T1TALA604

**Western Digital.**

**Revision 1.1 (28 July 2016)**

**Revision 1.2 (01 May 2018)**

*One MB is equal to one million bytes, one GB is equal to one billion bytes and one TB equals 1,000GB (one trillion bytes) when referring to storage capacity. Accessible capacity will vary from the stated capacity due to formatting and partitioning of the drive, the computer's operating system, and other factors.*

*The following paragraph does not apply to any jurisdiction where such provisions are inconsistent with local law: THIS PUBLICATION IS PROVIDED "AS IS" WITHOUT WARRANTY OF ANY KIND, EITHER EXPRESS OR IMPLIED, INCLUDING, BUT NOT LIMITED TO, THE IMPLIED WARRANTIES OF MERCHANTABILITY OR FITNESS FOR A PARTICULAR PURPOSE.*

*This publication could include technical inaccuracies or typographical errors. Changes are periodically made to the information herein; these changes will be incorporated in new editions of the publication. There may be improvements or changes in any products or programs described in this publication at any time. It is possible that this publication may contain reference to, or information about, Western Digital products (machines and programs), programming, or services that are not announced in your country. Such references or information must not be construed to mean that Western Digital Corporation intends to announce such Western Digital products, programming, or services in your country. Technical information about this product is available by contacting your local Western Digital product representative or on the Internet at: [support@wdc.com](mailto:support@wdc.com).*

*Western Digital Corporation may have patents or pending patent applications covering subject matter in this document. The furnishing of this document does not give you any license to these patents.*

© 2018 Western Digital Corporation or its affiliates.

*Ultrastar, RAFF, Data Lifeguard, the Western Digital logo and Ultrastar are registered trademarks or trademarks of Western Digital Corporation or its affiliates in the U.S. and/or other countries. Other trademarks are the property of their respective owners.*

*References in this publication to Western Digital-branded products, programs, or services do not imply that they will be made available in all countries. Product specifications provided are sample specifications and do not constitute a warranty. Actual specifications for unique part numbers may vary. Please visit the Support section of our website, [support@wdc.com](http://support@wdc.com), for additional information on product specifications. Pictures shown may vary from actual products.*

# Ultrastar® DC HA210

## Technical Reference Manual

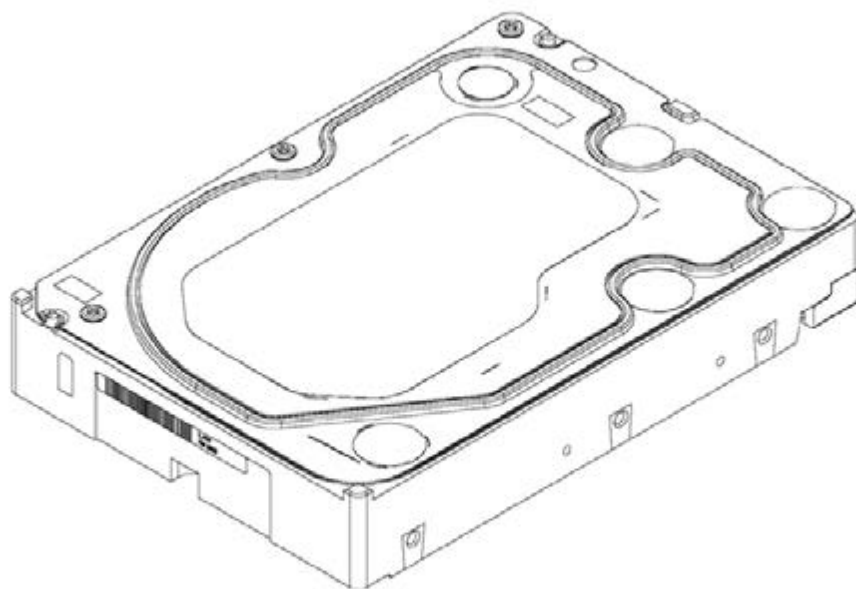

## TABLE OF CONTENTS

<b>1.0 DESCRIPTION AND FEATURES .....</b>	<b>7</b>
1.1 General Description .....	7
1.2 Product Features.....	7
<b>2.0 SPECIFICATION .....</b>	<b>9</b>
2.1 Performance Specifications .....	9
2.2 CacheFlow™ .....	10
2.2.1 Write Cache .....	10
2.2.2 Read Cache .....	10
2.3 Mechanical Specifications .....	11
2.3.1 Physical Dimensions .....	12
2.3.2 Drive Mounting .....	12
2.4 Electrical Specifications.....	13
2.4.1 Mean Current Requirements and Power Dissipation.....	13
2.4.2 Power Savings Modes .....	13
2.4.3 Input Voltage Requirements .....	15
2.4.4 Ripple .....	15
2.4.5 Power Connectors and Cables .....	15
2.5 Environmental Specifications.....	16
2.5.1 Shock and Vibration.....	16
2.5.2 Temperature and Humidity .....	17
2.5.3 Temperature Measurement .....	17
2.5.4 Cooling .....	18
2.5.5 Atmospheric Pressure.....	18
2.5.6 Acoustics .....	18
2.5.7 RoHS (Restriction of Hazardous Substances) .....	18
2.6 Agency Approvals.....	19
2.7 Full Model Number Specification .....	19
<b>3.0 PRODUCT FEATURES.....</b>	<b>20</b>
3.1 SATA 6 Gb/s.....	21
3.2 Time-Limited Error Recovery (TLER) .....	21
3.3 Rotary Acceleration Feed Forward (RAFF)™ .....	22
3.4 Perpendicular Magnetic Recording (PMR).....	23
3.5 IntelliSeek.....	23
3.6 Native Command Queuing (NCQ) .....	23
3.7 Pre-emptive Wear Leveling (PWL) .....	23
3.8 MicroFemto Slider .....	23
3.9 S.M.A.R.T. Command Transport (SCT) .....	24
3.9.1 Write Same .....	24
3.9.2 Temperature Reporting.....	24
3.10 World Wide Name (WWN) .....	24
3.11 Power Loss Data Protection .....	24
3.12 Hot Plug Support .....	25
3.13 Active LED Status .....	25
3.14 Fluid Dynamic Bearings (FDB) .....	25
3.15 Staggered Spinup and Activity Indication (SATA PowerPin 11) .....	25
3.15.1 Staggered Spinup .....	25
3.15.2 Activity Indication.....	25
3.16 48-bit Logical Block Addressing (LBA).....	26
3.17 Self-Monitoring, Analysis, and Reporting Technology (S.M.A.R.T.) .....	26
3.18 Password Security Mode.....	27
3.18.1 Master and User Passwords.....	27
3.18.2 Security Levels.....	27
3.19 Data Path Protection (DPP).....	27
3.20 Manufacturing Option Block .....	27

<b>4.0 RELIABILITY</b> .....	<b>28</b>
4.1 Reliability Considerations.....	28
4.2 Error Rates.....	28
4.2.1 Error Rates .....	28
4.2.2 Environmental Interference .....	29
4.3 Reliability Features Set .....	30
4.3.1 Data Lifeguard™* .....	30
4.3.2 Thermal Management .....	30
4.3.3 Internal Environmental Protection System .....	30
4.3.4 Defect Management.....	30
4.3.5 Recoverable Errors.....	30
4.3.6 Unrecoverable Errors .....	30
4.3.7 Automatic Defect Retirement .....	31
4.3.8 Error Recovery Process.....	31
<b>5.0 ATA COMMAND SET</b> .....	<b>32</b>
5.1 Host Interface Commands .....	32
5.1.1 ATA-7/ATA-8 Commands .....	32
5.1.2 SATA Commands .....	33
5.1.3 Obsolete Commands .....	33
5.1.4 SCT Commands.....	34
5.2 S.M.A.R.T. (BOh) .....	35
5.2.1 Read Attribute Values Sub-Command.....	35
5.2.2 Supported Attributes .....	36
5.2.3 Read Log Sector.....	37
5.3 Identify Device (ECh) .....	38
5.4 Set Features (EFh) .....	44
<b>6.0 DRIVE HANDLING AND MAINTENANCE</b> .....	<b>45</b>
6.1 Unpacking .....	45
6.1.1 Handling Precautions.....	45
6.1.2 Inspection of Shipping Container.....	45
6.1.3 Removal From Shipping Container.....	45
6.1.4 Removal From Static Shielding Bag .....	46
6.1.5 Moving Precautions .....	46
6.2 Hard Drive Installation .....	46
6.2.1 Backplane Usage .....	47
6.3 Maintenance.....	48
<b>7.0 GLOSSARY</b> .....	<b>49</b>

## LIST OF FIGURES

Figure 1 Mounting Dimensions .....	11
Figure 2 Drive Base Casting Thermocouple Location .....	17
Figure 3 Forced Airflow Direction .....	18
Figure 4 Dual Linear Sensor Rotational Acceleration Feed Forward (RAFF) .....	22
Figure 5 Manufacturing Option Block.....	27
Figure 6 SATA Cable Connections .....	46
Figure 7 Connector Pair Blind Mate Misalignment Allowable.....	47
Figure 8 Device Backplane Connection.....	47

## LIST OF TABLES

Table 1 Physical Specifications.....	9
Table 2 Performance Specifications .....	9
Table 3 Device/Head Register .....	16
Table 4 Maximum and Reliability Operating Temperature Limits (Drive Baseplate).....	17
Table 5 Full Model Number Description .....	19
Table 6 ATA-7/ATA-8 Command Opcodes .....	32
Table 7 Optional Subcommands .....	33
Table 8 Obsolete Command Opcodes .....	33
Table 9 SCT Action Codes.....	34
Table 10 Definitions for the 512 Bytes. ....	35
Table 11 Supported Attributes.....	36
Table 12 Log Address Definition .....	37
Table 13 Identify Device Command.....	38

## 1.0 DESCRIPTION AND FEATURES

### 1.1 General Description

Western Digital Ultrastar Capacity Enterprise hard drives offer up to 10 TB capacities and are available with SATA interface. With the highest error tolerance and MTBF of any capacity-optimized drive, Western Digital Ultrastar delivers the durability and reliability required in tightly packed vibration prone multi-drive systems. The combination of high-capacity, peak performance and robust design make Western Digital Ultrastar drives ideal for heavy workload environments, cloud storage, RAID arrays, external storage arrays, data warehousing, and mining applications.

### 1.2 Product Features

- **Serial ATA (SATA)** — Serial ATA (SATA) is the next generation bus interface for hard drives. It is designed to replace Parallel ATA, and has many advantages including increased transfer rate, improved signal integrity, enhanced data protection, and hot plug support.
- **Time-Limited Error Recovery (TLER)** — TLER prevents hard drive error recovery fallout by limiting the time the drive spends in error recovery, providing increased performance, improved availability, and lower total cost of ownership in RAID arrays.
- **Rotary Acceleration Feed Forward (RAFF)** — These drives employ RAFF technology to maintain hard drive performance in high vibration environments through adaptive compensation of the servo system.
- **Perpendicular Magnetic Recording (PMR)** — With PMR technology the magnetization of each data bit is aligned vertically to the spinning disk, rather than longitudinally as has been the case in hard drive technology for decades. This enables more data on a given disk than is possible with conventional longitudinal recording, and provides a platform for future expansion of hard drive densities.
- **IntelliSeek™** — Key product feature that calculates optimum seek speeds to lower power consumption, noise, and vibration.
- **Native Command Queuing (NCQ)** — Performance of a random I/O workload can be improved through intelligent re-ordering of the I/O requests so they read/write to and from the nearest available sectors and minimize the need for additional disk revolutions or head actuator movement. This improvement can be achieved through Native Command Queuing (NCQ), which is supported by these hard drives.
- **Pre-emptive Wear Leveling (PWL)** — This feature provides a solution for protecting the recording media against mechanical wear. In cases where the drive is so busy with incoming commands that it is forced to stay in a same cylinder position for a long time, the PWL control engine initiates forced seeks so that disk lubricant maintains an even distribution and does not become depleted. This feature ensures reliability for applications that perform a high incidence of read/write operations at the same physical location on the disk.
- **MicroFemto Slider** — These drives incorporate the next generation of femto slider form factor in which the read/write head is mounted on the small, lightweight microfemto slider that allows the head to move more quickly from track to track on the disk.
- **S.M.A.R.T. Command Transport (SCT)** — The SCT Command Transport feature set provides a method for a host to send commands and data to a device and for a device to send data and status to a host using log pages.
- **World Wide Name (WWN)** — The World Wide Name (WWN) defined in ATA/ATAPI-7 is a modification of the IEEE extended unique identifier 64 bit standard (EUI-64) and is comprised of three major components: naming authority, organizationally unique identifier (OUI) and serial number. This product's OUI is 0014EEh.

- **Reliability Features Set-Data Lifeguard™** — Representing the ongoing commitment to data protection, Data Lifeguard includes features that enhance the drive’s ability to prevent data loss. Data Lifeguard data protection utilities include thermal management, an environmental protection system, and embedded error detection and repair features that automatically detect, isolate, and repair problem areas that may develop over the extended use of the hard drive. With these enhanced data reliability features, the drive can perform more accurate monitoring, error repair, and deliver exceptional data security.
- **Power Loss Data Protection** — Upon power loss, the drive utilizes stored spindle energy to back up the HDD cache to on-board flash. This allows deeper write queues which boosts performance, while minimizing data loss/corruption such as write splices that can occur during unexpected power losses.
- **Hot Plug Support** — SATA supports hot plugging (also known as “hot swapping”), the ability to swap out a failed hard drive without having to power down the system or reboot. This capability contributes to both data availability and serviceability without any associated downtime, making it a critical feature for extending SATA into enterprise applications.
- **Active LED Status** — The drive supports external LED requirements. It provides an activity LED output which is ON during command execution and OFF otherwise.
- **Fluid Dynamic Bearings (FDB)** — Bearing design that incorporates a layer of high-viscosity lubricant instead of ball bearings in the hard drive spindle motor. As an alternative to conventional ball bearing technology, FDB designs provide increased non-operational shock resistance, speed control, and improved acoustics.
- **Staggered Spin-Up** — Next generation SATA 6 Gb/s feature that allows the system to control whether the drive will spin up immediately or wait until the interface is fully ready.
- **CacheFlow™** — This unique, multi-generation caching algorithm evaluates the way data is read from and written to the drive and adapts “on-the-fly” to the optimum read and write caching methods. CacheFlow minimizes disk seek operations and overheads due to rotational latency. CacheFlow supports sequential and random write cache. With write cache and other CacheFlow features, the user can cache both read and write data. The cache can hold multiple writes and collectively write them to the hard disk.
- **48-bit Logical Block Addressing (LBA)** — Western Digital SATA drives support both 48-bit and 28-bit LBA and CHS-based addressing. LBA is included in advanced BIOS and operating system device drivers and ensures high capacity disk integration.
- **Power Management** — The drive supports the ATA and SATA power management command set, allowing the host to reduce the power consumption of the drive by issuing a variety of power management commands.
- **Self-Monitoring, Analysis, and Reporting Technology (S.M.A.R.T.)** — S.M.A.R.T. enables a drive’s internal status to be monitored through diagnostic commands at the host level and during offline activities. S.M.A.R.T. devices employ data analysis algorithms that are used to predict the likelihood of some near-term degradation or fault conditions. When used with a S.M.A.R.T. application, the drive can alert the host system of a negative reliability status condition. The host system can then warn the user of the impending risk of data loss and recommend an appropriate action.
- **ATA Security** — The drive supports the ATA Security Mode Feature set. The ATA Security Mode feature set allows the user to create a device lock password that prevents unauthorized hard disk access even if the drive is removed from the host computer. The correct password must be supplied to the hard drive in order to access user data. Both the User and Master Password features are supported, along with the High and Maximum security modes. The Master Password Revision code is also supported. This feature varies by drive configuration and may not be available on all configurations.
- **Data Path Protection (DPP)** — A feature that prevents possible electronic failures from corrupting data on the hard drive.



## 2.0 SPECIFICATION

Table 1 Physical Specifications

Physical Specifications <sup>1</sup>	HUS722T2TALA604	HUS722T1TALA604
Capacity	2 TB	1 TB
Interface	SATA 6 Gb/s	SATA 6 Gb/s
Physical Bytes Per Sector	512	512
Host Bytes Per Sector	512	512
User Sectors per Drive	3,907,029,168	1,953,525,168
Servo Type	Embedded	Embedded
Channel Recording Method	LDPC—Low Density Parity Code	

<sup>1</sup> As used for storage capacity, one megabyte (MB) = one million bytes, one gigabyte (GB) = one billion bytes, and one terabyte (TB) = one trillion bytes. Total accessible capacity varies depending on operating environment. As used for buffer or cache, one megabyte (MB) = 1,048,576 bytes. As used for transfer rate or interface, megabyte per second (MB/s) = one million bytes per second, and gigabit per second (Gb/s) = one billion bits per second. Effective maximum SATA 6 Gb/s transfer rate calculated according to the Serial ATA specification published by the SATA-IO organization as of the date of this document. Visit [www.sata-io.org](http://www.sata-io.org) for details.

## 2.1 Performance Specifications

Table 2 Performance Specifications

Average Seek (without overhead) - Read - Write	7.7 ms average 8.3 ms average
Average Latency	4.2 ms (nominal)
Rotational Speed	7200 RPM (nominal)
Data Transfer Rate (maximum at OD) <sup>1</sup> - Maximum burst interface transfer rate - Maximum sustained interface transfer rate	6 Gb/s HUS722T2TALA604: 200 MB/s HUS722T1TALA604: 184 MB/s
Buffer Size	128 MB
Spindle Start Time - From Power-on to Drive Ready <sup>2</sup>	15s average (FAST spinup mode) 18s average (STANDARD spinup mode)
Spindle Stop Time	<10s average
Load/Unload Cycles <sup>3</sup>	600,000 minimum

<sup>1</sup> As used for transfer rate or interface, megabyte per second (MB/s) = one million bytes per second, and gigabit per second (Gb/s) = one billion bits per second. Effective maximum SATA 6 Gb/s transfer rate calculated according to the Serial ATA specification published by the SATA-IO organization as of the date of this document. Visit [www.sata-io.org](http://www.sata-io.org) for details.

<sup>2</sup> Defined as the time from power-on to the setting of Drive Ready and Seek Complete including calibration. Controlled unload at ambient condition.

## 2.2 CacheFlow™

CacheFlow is the unique, multi-generation disk caching system. It incorporates read cache with write cache.

CacheFlow was designed to obtain maximum performance with today's most popular operating systems and applications. CacheFlow increases performance over prior caching algorithms by increasing the number of times that requested data is in the cache. This reduces the number of host commands that require actual media access thereby improving overall drive performance.

Typical applications perform a variety of access patterns, such as random, sequential, and repetitive. CacheFlow is designed to dynamically adapt to the changes in access patterns that occur during the course of application execution.

Random mode is the default operational mode for CacheFlow. Once CacheFlow detects a sequential access pattern, it leaves random mode. CacheFlow also performs predictive read operations to increase the probability that data requested in future commands already exists in the cache.

CacheFlow partitions the buffer into multiple segments to allow for the fact that applications may access multiple non-contiguous areas on the disk. CacheFlow tracks the amount of valid data in each segment and controls the deallocation of segments to maximize drive performance.

### 2.2.1 Write Cache

CacheFlow is designed to improve both single and multi-sector write performance by reducing delays caused by seek time and rotational latency.

The write cache adaptively detects random and sequential access patterns during application execution.

If a defective sector is found during a write cache operation, that sector is automatically relocated before the write occurs.

### 2.2.2 Read Cache

CacheFlow implements a multiple segment read cache. Cache segments are assigned to read commands as they are received from the host.

Each read segment consists of pre and post read sectors in addition to the host-requested sectors. This maximizes the amount of cache data in the drive's buffer, thereby increasing the likelihood of cache hits and improving overall performance.

## 2.3 Mechanical Specifications

Figure 1 shows the mounting dimensions and locations of the screw holes for the drive.

Figure 1 Mounting Dimensions

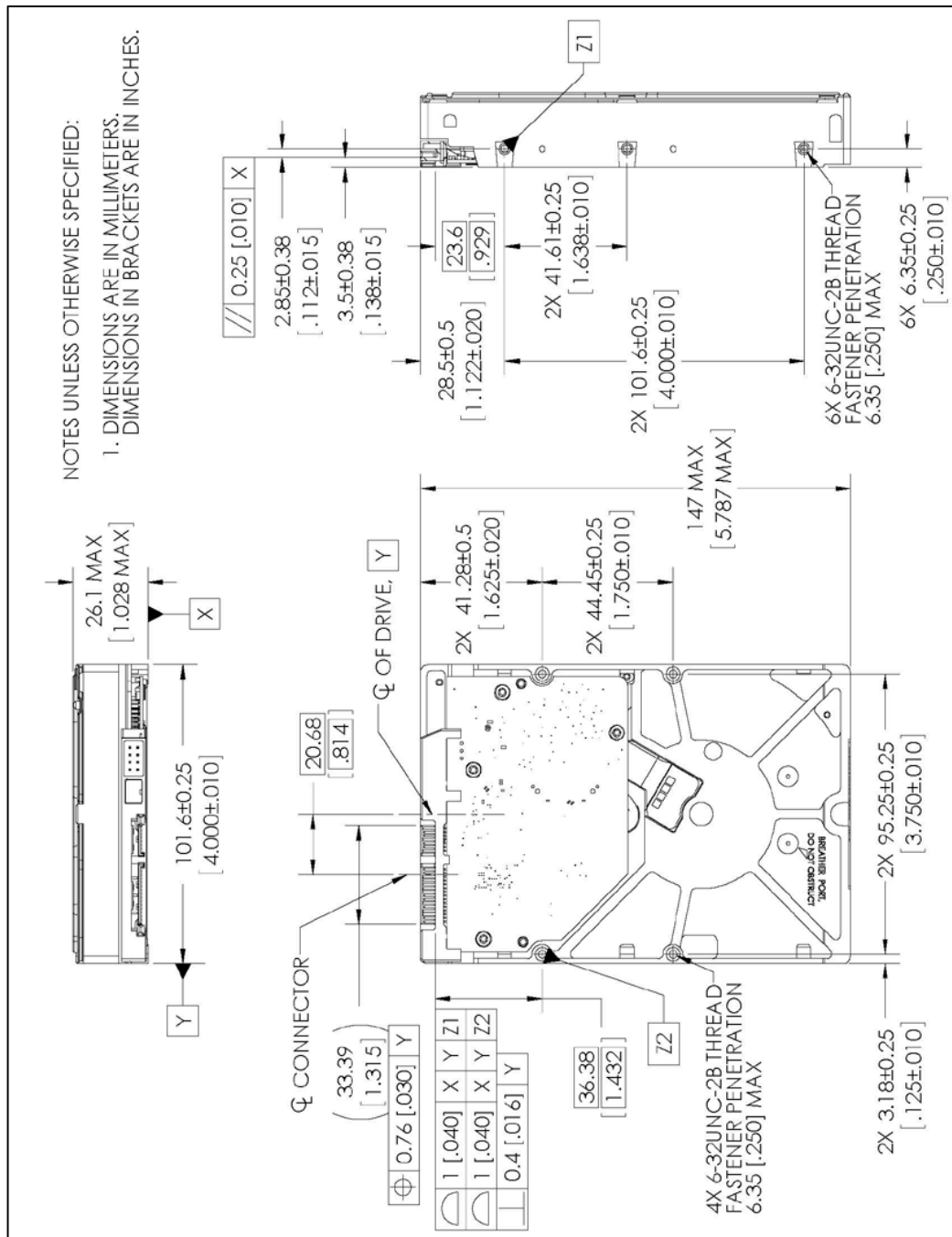

### 2.3.1 Physical Dimensions

	English		Metric	
	Dimension	Tolerance	Dimension	Tolerance
Height	1.028 inches	MAX	26.1 mm	MAX
Length	5.787 inches	MAX	147.0 mm	MAX
Width	4.00 inches	±0.01 inch	101.6 mm	±0.25 mm
Weight	1.41 pounds	±10%	0.64 kg	±10%

### 2.3.2 Drive Mounting

Use either the four bottom screws or at least four of the side mounting screws to rigidly support the drive and prevent vibration. Some adaptor frames may not have the mechanical design structure capable of mounting the drive to meet the specified shock and vibration requirements.

The hard drive itself does not provide electrical isolation between mounting locations and drive ground connection. If electrical isolation is required, the system designer or integrator would be responsible for providing a solution.

#### 2.3.2.1 Mounting Restrictions

If your system does not support hot plugging (see “Hot Plug Support on page.25), it must be turned off and unplugged before installing your hard drive.

#### 2.3.2.2 Orientation

You can mount the hard drive in the X, Y, or Z axis, depending upon the physical design of your system. For best results, mount the drive with all four screws grounded to the chassis. If all four screws are not used, see "Grounding" on page.12.

#### 2.3.2.3 Screw Type and Screw Length Limitations

The hard drive should be mounted to the chassis using four 6-32 screws. Recommended screw torque is 5 in-lb. Maximum screw torque is 10 in-lb.

**CAUTION: Screws that are too long can damage the hard drive. Hard drive screw penetration can differ between products depending upon hard drive design. Western Digital’s minimum design criteria is to always meet the SFF 8301 industry standard specification. The industry standard as defined in the SFF 8301 specifies a maximum of 3 mm screw penetration, and for a minimum of 2.4 mm of thread engagement from both the screw and the hard drive.**

See Figure 1 for allowable fastener penetration for this product family.

#### 2.3.2.4 Grounding

The PCBA and HDA grounds are always connected together in the drive and cannot be disconnected. The drive mounting screws, unless intentionally isolated, will provide additional ground connections between the HDA and the system chassis. If the drive isn’t grounded via mounting screws as described under “Hard Drive Installation” on Page.46, there may be increased electrical emissions (EMI).

## 2.4 Electrical Specifications

### 2.4.1 Mean Current Requirements and Power Dissipation

Operating Mode	Mean Current <sup>1, 2</sup>		Mean Power <sup>1, 2</sup>
	12 VDC	5 VDC	
Spinup Standard <sup>3</sup>	1710 mA (max) 735 mA	520 mA (peak) 295 mA	-
Spinup Fast	2385 mA (max) 1350 mA	550 mA (peak) 295 mA	-
Spinup Green	1190 mA (max) 510 mA	505 mA (peak) 295 mA	-
Operational Peak Current	1545 mA (peak) 1600 mA (max)	870 mA (peak) 860 mA (max)	-
Sequential Read	315 mA	720 mA	7.4W
Sequential Write	315 mA	730 mA	7.4W
Random Read/Write	485 mA	455 mA	8.1W
Idle	315 mA	430 mA	5.9W

<sup>1</sup> When running at 3 Gb/s or as a single ported device, power will be lower than the value listed. <sup>2</sup> All peak and mean values are typical (measured at 25°C) except where specified as maximum. <sup>3</sup> Default spinup mode when not otherwise overridden.

#### 2.4.1.1 Power Savings Modes<sup>1</sup>

Mode	Mean Current <sup>2</sup>		Mean Power <sup>2</sup> DIPM Off
	12 VDC	5 VDC	
Idle_A	310 mA	290 mA	5.2W
Idle_B	295 mA	290 mA	5.0W
Idle_C	110 mA	290 mA	2.8W
Standby_Y	110 mA	290 mA	2.8W
Standby_Z	10 mA	285 mA	1.5W

<sup>1</sup> When running at 3 Gb/s or as a single ported device, power will be lower than the value listed.

<sup>2</sup> All peak and mean values are typical (measured at 25°C) except where specified as maximum.

### 2.4.2 Power Savings Modes

This product is capable of supporting both legacy ATA Advanced Power Management (APM) mode and the new more extensive Extended Power Conditions (EPC) standards. Unless otherwise specified, the default disk drive is shipped with the EPC mode enabled, and the legacy APM modes can be enabled via the Set Feature command (Feature '4A'h, Sub Command '04'h). These two power savings implementations are exclusively used, and thus not simultaneously supported.

#### 2.4.2.1 SATA Advanced Power Management

This drive supports the legacy ATA power management commands that lower the average power consumption of the hard drives. For example, to take advantage of the lower power consumption modes of the drive, an energy efficient host system could implement a power management scheme that issues a Standby Immediate command when a host resident disk inactivity timer expires. The Standby Immediate command causes the drive to spin down and enter a low-power mode. Subsequent disk access commands would cause the drive to spin up and execute the new command. To avoid excessive wear on the drive due to the starting and stopping of the HDA, set the host's disk inactivity timer to no shorter than ten minutes.

### 2.4.2.2 SATA Extended Power Conditions (EPC)

Western Digital drives additionally support T13 Extended Power Conditions, as stated in the ACS-2 specification. Power savings features, normally only available in notebook drives, are now included in our Enterprise products. With these features enabled, drive power can be reduced automatically via inactivity timer, or manually via Host command. In timer based mode, the drive automatically starts reducing its power based on inactivity of commands from the Host. With progression into the idle states, the drive saves more and more power, but consequently takes longer to recover and respond to Host media commands.

A summary of the new low power modes and what the drive does in each mode is shown below:

#### Idle\_A

- Heads Floating Over Disk
- <10 ms recovery

#### Idle\_B

- Heads Parked
- <650 ms recovery

#### Idle\_C

- Heads Parked, Reduced RPM
- 3-15 sec recovery (see the Power Conditions Log for the drives actual recovery time)
- Idle\_c recovery current limited to the maximum user mode power.

#### Standby\_Y

- Heads Parked, Reduced RPM
- 3-15 sec recovery (see the Power Conditions Log for the drives actual recovery time)
- Standby\_y recovery can use full spin up power.

#### Standby\_Z

- Traditional standby
- Drive not spinning
- Recovery is similar to a typical TTR (Time To Ready) for the HDD

Western Digital has added the Power Condition Log, which defines the support, enable bits, and timers for all power conditions. The power management timers start running after all Host commanded drive activity is complete, and will run during drive background operations, but do not take effect until those background operations are completed. The timer expiration min/max values are visible to the Host/Initiator, but are rounded silently by the drive to its internal min/max values. The timer enable and timer values can be marked independently as changeable. Please note that some Host Operating Systems may be unable to take advantage of the inactivity timers, as they constantly access the Drive with writes to update a time stamp. In these situations it is advisable to extend the Idle\_B timer value beyond the time interval of the writes, or to disable the timer entirely. Please see your Western Digital representative for help with questions about these features.

### 2.4.3 Input Voltage Requirements

The input voltage requirements are  $+5.0V \pm 5\%$  and  $+12.0V \pm 10\%$ .

### 2.4.4 Ripple

	+ 12 VDC	+ 5 VDC
Maximum Frequency	200 mV (double amplitude) 0-30 MHz	100 mV (double amplitude) 0-30 MHz

### 2.4.5 Power Connectors and Cables

#### Serial ATA Connectors

For information on SATA data connectors, including the pin definitions of the SATA connectors and the corresponding signal names and signal functions, refer to the latest SATA specification available for download at [www.serialata.org](http://www.serialata.org).

#### Cabling Requirements for Serial ATA

The SATA cable consists of four conductors in two differential pairs. The cable may also include drain wires to be terminated to the ground pins in the SATA cable receptacle connectors. See the SATA specification for cable specifications. The cable's maximum length is one meter.

## 2.5 Environmental Specifications

### 2.5.1 Shock and Vibration

Table 3 Device/Head Register

<b>Shock</b>															
Operating	30G, 2 ms read/write) 65G, 2 ms (read)														
Non-operating (2 ms)	300G														
<i>Note: Half-sine wave, measured without shock isolation and without non-recoverable errors.</i>															
<b>Rotational Shock Non-Operating</b>															
Amplitude	20K rad/sec <sup>2</sup>														
Duration	2 ms														
<b>Vibration</b>															
Operating	Swept Sine: 20-300 Hz, 0.75G (0 to peak) Sweep Rate: 0.5 octave/minute minimum Random: 0.004 g <sup>2</sup> /Hz (10-300 Hz)														
Non-operating	Swept Sine: 20-500 Hz, 4.0G (0 to peak) Sweep Rate: 0.5 octave/minute minimum Random: 0.05 g <sup>2</sup> /Hz (10-300 Hz)														
<b>Rotational Vibration</b>															
12.5 rad/sec <sup>2</sup> based on the following PSD profile maintaining <20% performance degradation:															
	<table border="1"> <thead> <tr> <th>Frequency (Hz)</th> <th>20</th> <th>200</th> <th>300</th> <th>900</th> <th>1400</th> <th>2000</th> </tr> </thead> <tbody> <tr> <td>(Rad/sec<sup>2</sup>)<sup>2</sup>/Hz</td> <td>0.035</td> <td>0.035</td> <td>0.2</td> <td>0.2</td> <td>0.002</td> <td>0.002</td> </tr> </tbody> </table>	Frequency (Hz)	20	200	300	900	1400	2000	(Rad/sec <sup>2</sup> ) <sup>2</sup> /Hz	0.035	0.035	0.2	0.2	0.002	0.002
Frequency (Hz)	20	200	300	900	1400	2000									
(Rad/sec <sup>2</sup> ) <sup>2</sup> /Hz	0.035	0.035	0.2	0.2	0.002	0.002									

#### Operating Vibration

Drives are tested by applying a random excitation in each linear axis, one axis at a time. The drive incurs no physical damage and no hard errors while subjected to continuous vibration not exceeding the level listed in Table 3. Operating performance may degrade during periods of exposure to continuous vibration.

#### Non- Operating Vibration

*Note:* This specification applies to handling and transportation of unmounted drives.

Drives are tested by applying a random excitation in each linear axis, one axis at a time. The drive incurs no physical damage when subjected to continuous vibration not exceeding the level listed in Table 3.

#### Packaged Shock and Vibration

The shipping packaging is designed to meet the National/International Safe Transit Association (N/ ISTA) standards for packaged products. The drive incurs no physical damage when subjected to the N/ ISTA standards.



## 2.5.2 Temperature and Humidity

Temperature & Humidity	
Operating ambient temperature <sup>1</sup>	5°C to 60°C
Max base casting temperature <sup>2</sup>	60°C
S.M.A.R.T. temperature value	reported within ±3°C
Humidity	5-95% RH non-condensing 30°C (maximum wet bulb)
Thermal Gradient	20°C/hour (maximum)
Humidity Gradient	20%/hour (maximum)
Non-operating Temperature	-40°C to 70°C
Humidity	5-95% RH non-condensing 35°C (maximum wet bulb) for up to 21 days <sup>3</sup>
Thermal Gradient	30°C/hour (maximum)
Humidity Gradient	20%/hour (maximum)
<sup>1</sup> Ambient temperature is defined as the temperature of the environment immediately surrounding the drive. The system environment must allow sufficient air flow to limit maximum surface temperatures as defined. <sup>2</sup> See Figure 2 Actual drive case temperature should be below 60°C and within the 5-60°C operating ambient temperature. <sup>3</sup> Unless still in Western Digital's factory sealed bag which allows up to 40°C without limit.	

## 2.5.3 Temperature Measurement

Drive component temperatures measured at the drive baseplate thermocouple location must remain within the limits specified in Table 4. Figure 2 shows the temperature measurement location. Sustained operation at temperatures in excess of the reliability values degrades the MTBF rating. Short excursions up to, but not exceeding, the maximum values will not affect the MTBF rating. Maximum component temperature ratings must not be exceeded under any operating condition, or product warranty will be void.

Table 4 Maximum and Reliability Operating Temperature Limits (Drive Baseplate)

Component	Location	Maximum	Reliability <sup>1</sup>
Drive baseplate	See Figure 2	60°C (140°F)	40°C
<sup>1</sup> Sustained operation at temperatures in excess of the reliability values degrades the MTBF rating.			

Figure 2 Drive Base Casting Thermocouple Location

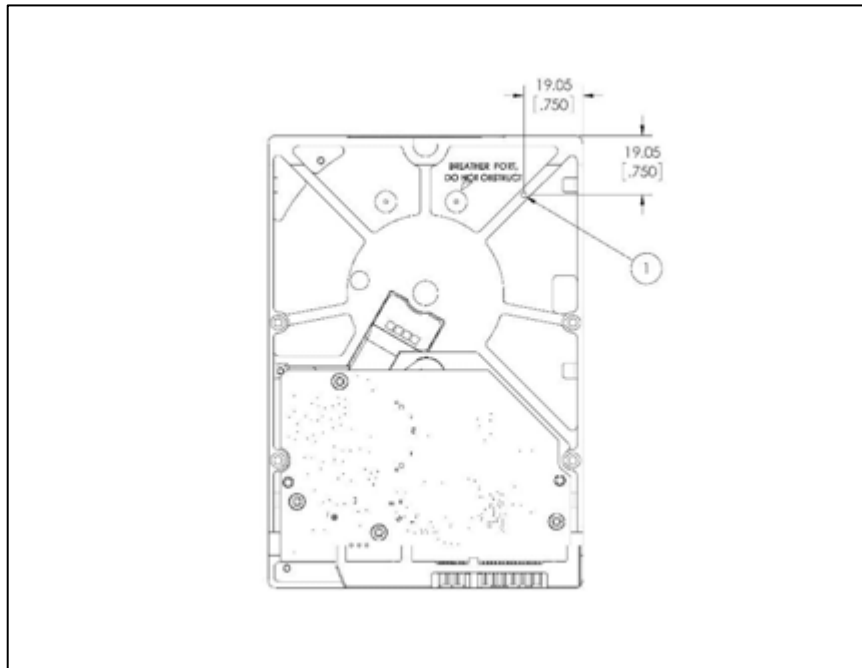

### 2.5.4 Cooling

If forced air cooling is required, the recommended airflow from one or more fans as indicated in Figure 3.

Figure 3 Forced Airflow Direction

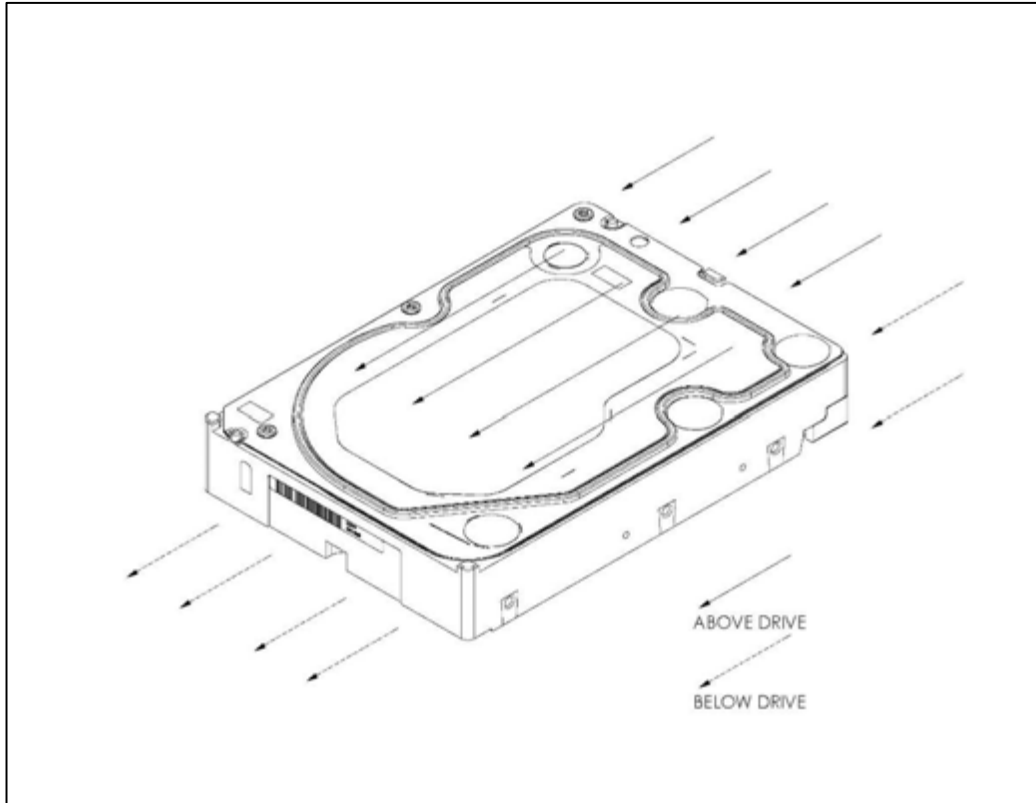

### 2.5.5 Atmospheric Pressure

Altitude	
Operating	-1,000 feet to 10,000 feet (-305M to 3,050M)
Non-	-1,000 feet to 40,000 feet (-305M to 12,200M)

### 2.5.6 Acoustics

TYPICAL SOUND POWER LEVEL <sup>1</sup>	
Idle Mode (average dBA) <sup>2</sup>	25
Seek Mode (average dBA)	28
<sup>1</sup> Measured per ECMA-74/ISO 7779.	
<sup>2</sup> No audible pure tones.	

### 2.5.7 RoHS (Restriction of Hazardous Substances)

Western Digital hard drive products manufactured and sold worldwide after June 8, 2011, meet or exceed Restriction of Hazardous Substances (RoHS) compliance requirements as mandated by the RoHS Directive 2011/65/EU. RoHS aims to protect human health and the environment by restricting the use of certain hazardous substances in new equipment, and consists of restrictions on lead, mercury, cadmium, and other substances.

## 2.6 Agency Approvals

**Ultrastar DC HA210 Regulatory Number (R/N):** 800032

These drives meet the standards of the following regulatory agencies:

- **Underwriters Laboratories:** Bi-National UL Standard CAN/CSA-C22.2 No. 60950/UL 60950-1. Standard for Safety of Information Technology Equipment, including Electrical Business Equipment (File E101559).
- **TUV NORD CERT GmbH:** IEC 60950-1 per EN 60950-1, Standard for Safety of Information Technology Equipment, including Electrical Business Equipment. IEC 60065. Standard of Safety for Audio, Video, and Similar Electronic Apparatus.
- **CE Compliance for Europe:** Complies with EN 55022: 2010 RF/ Conducted Emissions and EN 55024: 2010 Immunity requirements. Including EU Directive 2011/65/EU RoHS II requirements.
- **RCM Compliance for Australia:** Verified to comply with AS/NZS CISPR 22 for RF Emissions as required by the Australian Communications Authority.
- **Korean KC Mark:** Registered as a Class-B product with the South Korean Ministry of Information and Communication.
- **Taiwan BSMI EMI Certification:** Certified as a Class-B product with the Bureau of Standards Metrology and Inspection (BSMI).

## 2.7 Full Model Number Specification

Table 5 below provides a summary specification of the model number suffix for this product platform.

*Table 5 Full Model Number Description*

Model Number Format	ID	Product Brand	RPM	Description
HUS722TxTALA604	YCB	Ultrastar DC HA210	7200	Ultrastar DC HA210 128 MB SATA 6 Gb/s

## 3.0 PRODUCT FEATURES

- SATA 6 Gb/s
- Time Limited Error Recovery (TLER)
- Rotary Acceleration Feed Forward (RAFF)<sup>™</sup>
- Perpendicular Magnetic Recording (PMR)
- IntelliSeek<sup>™</sup>
- Native Command Queuing (NCQ)
- Pre-Emptive Wear Leveling (PWL)
- MicroFemto Slider
- S.M.A.R.T. Command Transport (SCT)
- World Wide Name (WWN)
- Hot Plug Support
- Active LED Status
- Fluid Dynamic Bearings (FDB)
- Staggered Spin-Up and Activity Indication (SATA Power Pin 11)
- 48-bit Logical Block Addressing (LBA)
- Self-Monitoring, Analysis, and Reporting Technology (S.M.A.R.T.)
- Security Mode
- Data Path Protection (DPP)
- Manufacturing Option Block

## 3.1 SATA 6 Gb/s

SATA 6 Gb/s is the next generation interface for SATA hard drives. It adds to the functionality of the SATA 3 Gb/s interface with the following features:

- **Native Command Queuing (NCQ)** — server feature for performance in random I/O transaction environments. It aggregates many small random data transfers and allows the disk to reorder the commands in a sequential order for faster access.
- **Staggered Spin-up** — allows the system to control whether the drive will spin up immediately or wait until the interface is fully ready before spinning up.
- **Asynchronous Signal Recovery (ASR)** — robustness feature that improves signal recovery.
- **Enclosure Services** — defines external enclosure management and support features.
- **Backplane Interconnect** — defines how to lay out signal line traces in a backplane.
- **Auto-activate DMA** — provides increased command efficiency through automated activation of the DMA controller.

## 3.2 Time- Limited Error Recovery (TLER)

Western Digital has delivered coordinated error management in the form of Time Limited Error Recovery (TLER). TLER-capable hard drives will perform the normal error recovery and, after 7 seconds, issue an error message to the RAID controller and defer the error recovery task until a later time. With coordinated error handling, the hard drive is not dropped from the RAID array, thereby avoiding the entire RAID recovery, replacement, rebuild, and return experience.

The error handling is further coordinated between the TLER-capable hard drive and the RAID card. The TLER capable drive will respond without waiting on the error to be resolved. RAID cards are very capable of handling this with a combination of parity protection and journaling. The RAID card flags the error in the error log and proceeds to deliver data using parity protection until the drive retries its own error recovery and corrects the error. This is quite similar to error management proven in SCSI- RAID for many years. Though TLER is designed for RAID environments, it is fully compatible with and will not be detrimental when used in non-RAID environments.

### 3.3 Rotary Acceleration Feed Forward (RAFF)<sup>™</sup>

Rotary Acceleration Feed Forward (RAFF) helps to overcome the effects of rotational vibration (RV) on a hard drive by generating an additional control effort to counter the RV disturbances, thereby keeping the drive head(s) within the safe operating region during reading and writing operations.

Figure 4 Dual Linear Sensor Rotational Acceleration Feed Forward (RAFF)

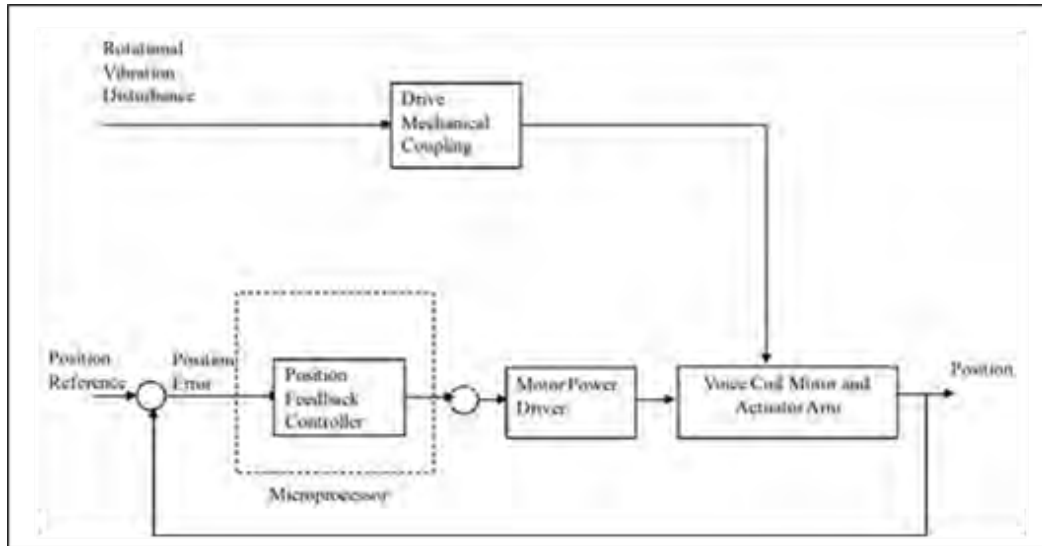

The RAFF implementation has three major components: RV sensing, RV control effort feed-forwarding and adaptation to environmental conditions.

- **RV sensing** in the RAFF implementation is accomplished by using two relatively inexpensive linear accelerometers placed on the printed circuit board assembly (PCBA). The sensor locations are optimized for separation distance and PCB mounting conditions. Since the difference signal from two similar linear accelerometers placed in a parallel orientation and separated by some distance is indicative of RV, the signals are subtracted from each other to generate a Differential Sensor Signal (DSS).
- **RV control effort feed-forwarding** is achieved by digitizing the DSS, then, sending it to the microprocessor of the drive. Using a control algorithm, the microprocessor generates a control effort signal based on the DSS. This feed forward control effort is in addition to the conventional servo control approach in hard drive operations.
- **Adaptation to environmental conditions** is crucial to the successful deployment of RAFF. This design intelligently applies RAFF selectively and adapts to with individual drive parameters to maintain maximum performance in the hard drive.

### 3.4 Perpendicular Magnetic Recording (PMR)

In perpendicular magnetic recording (PMR), the magnetization of each data bit is aligned vertically to the spinning disk, rather than longitudinally as has been the case in hard drive technology for decades. In longitudinal recording, as the bits become smaller and closer together, they experience an increasing demagnetizing field, much like two bar magnets that are placed end-to-end repel one another. A property of the media called coercivity must be increased to counteract the demagnetization to keep the bits stable under thermal fluctuations; otherwise data corruption may occur over time. Higher media coercivity has pushed the recording head write field to the limit of known materials.

In perpendicular recording, the adjacent bits attract instead of repel (as with bar magnets placed side by side,) creating more thermally stable bits. In addition, the media contains a magnetically soft underlayer (SUL) beneath the recording layer. This SUL allows a larger effective write field, thus higher coercivity media, enabling further increases in density. Lastly, because of the vertical orientation of the bits, the PMR recording layer tends to be thicker than that used for longitudinal recording, providing increased signal for the read heads. All of these benefits enable Western Digital engineers to reliably pack more data on a given disk than is possible with conventional longitudinal recording.

### 3.5 IntelliSeek

This unique IntelliSeek technology proactively calculates an optimum seek speed to eliminate hasty movement of the actuator that produces noise and requires power, which is common in other drives. With IntelliSeek, the actuator's movement is controlled so the head reaches the next target sector just in time to read the next piece of information, rather than rapidly accelerating and waiting for the drive rotation to catch up. This smooth motion reduces power usage by more than 60 percent compared with standard drives, as well as quiets seek operation and lowers vibration.

### 3.6 Native Command Queuing (NCQ)

These drives support Native Command Queuing. NCQ is a true Enterprise feature for environments such as database, Web servers, and e-mail servers.

Performance of a random I/O workload can be improved through intelligent re-ordering of the I/O requests so they read/write to and from the nearest available sectors and minimize the need for additional disk revolutions or head actuator movement. This improvement is achieved through Native Command Queuing (NCQ).

NCQ allows the drive to re-order read commands, thereby increasing random read IOPs. Additional NCQ features that can prove beneficial include a Write Cache disabled IOP increase and a queuing implementation built upon an existing, highly automated cache architecture. Queued reads in NCQ leverage the same re-ordering schemes used for write caching. The firmware design maintains the "order" of overlapping/colliding queued commands. NCQ is designed to excel in multi-threaded environments with high random I/O loads.

### 3.7 Pre-emptive Wear Leveling (PWL)

This feature provides a solution for protecting the recording media against mechanical wear. In cases where the drive is so busy with incoming commands that it is forced to stay in a same cylinder position for a long time, the PWL control engine initiates forced seeks so that disk lubricant maintains an even distribution and does not become depleted. This feature ensures reliability for applications that perform a high incidence of read/write operations at the same physical location on the disk.

### 3.8 MicroFemto Slider

These drives incorporate the next generation of femto slider form factor in which the read/write head is mounted on the small, lightweight microfemto slider that allows the head to move more quickly from track to track on the disk. Western Digital's microfemto heads enhance tracking and increase shock tolerance, producing a highly stable high-density drive platform.

## 3.9 S.M.A.R.T. Command Transport (SCT)

The SCT Command Transport feature set provides a method for a host to send commands and data to a device and for a device to send data and status to a host using log pages. Standard ATA commands may be interspersed with SCT commands, but SCT commands cannot be nested. SCT commands that do not require a subsequent data transfer operation are not interspersed with any ATA commands or each other.

The SCT Command Transport feature set provides a method for a host to send commands and data to a device and for a device to send data and status to a host using log pages. This capability is used to pass commands through a driver interface or a bridge where new or unknown commands may be filtered and not passed to the drive. SCT is also used for issuing commands that require more than 8 parameter bytes. ATA8-ACS provides detailed information on the usage and capabilities of SCT. The SCT feature set includes the following commands:

- Write Same
- Temperature Reporting

### 3.9.1 Write Same

The Write Same command allows the host to erase the media, or write a pattern repeatedly across the media, with a minimum of data transfer from the host. The host can clear the entire media to zeros or a specific pattern by sending this command with the pattern as a parameter—no data transfer is necessary. Write Same can write the entire media, or just a portion of the media. The host can monitor the progress of the Write Same by issuing SCT Status requests. This frees the host system to do other tasks while the media is being cleared.

### 3.9.2 Temperature Reporting

The SCT Temperature Reporting (SCT TR) feature allows a host system to access temperature information in the drive. The S.M.A.R.T. temperature value is reported within  $\pm 3^{\circ}\text{C}$  of the base casting temperature. This information can be used to control fans or adjust the usage of various system components to keep the drive within its normal operating temperature. Applications include Enterprise, Laptop, Desktop and Consumer Electronics. SCT TR reports the maximum and minimum sustained operating limits, warning level limits, and drive damage limits. In addition to reporting the limits, SCT TR returns the current drive temperature (a temperature history which the host can use to predict heating or cooling trends) and the maximum temperature achieved during the lifetime of the drive as well as the highest temperature achieved since the power was applied to the drive. Detailed information on this capability can be found in ATA8-ACS.

## 3.10 World Wide Name (WWN)

It has become a critical requirement that hard drives be uniquely identified by computer systems. This allows a drive to maintain its identity as it is transported from system to system or placed on a network. IEEE has defined a format for serial numbers that is widely recognized in the computing industry by adding World Wide Name (WWN) to ATA/ATAPI-7 in 2002.

The World Wide Name (WWN) defined in ATA/ATAPI-7 is a modification of the IEEE Extended Unique Identifier 64 bit standard (EUI-64) and is comprised of three major components: naming authority, organizationally unique identifier (OUI) and serial number. This product's OUI is 0014EEh.

## 3.11 Power Loss Data Protection

Upon power loss, the drive utilizes stored spindle energy to back up the HDD cache to on-board flash. This allows deeper write queues which boosts performance, while minimizing data loss/ corruption such as write splices that can occur during unexpected power losses.



## 3.12 Hot Plug Support

SATA supports hot plugging (also known as “hot swapping”), the ability to swap out a failed hard drive without having to power down the system or reboot. This capability contributes to both data availability and serviceability without any associated downtime, making it a critical feature for extending SATA into enterprise applications.

The drive supports hot plugging only in systems where a SATA hard drive storage backplane is used. The SATA 3.0 specification requires staggered pins for both the hard drive and drive receptacles.

Staggered pins mate the power signals in the appropriate sequences required for powering up the hot plugged device. These pins are also specified to handle in excess of the maximum allowed inrush current that occurs during drive insertion. SATA-compliant devices thus need no further modification to be hot pluggable and provide the necessary building blocks for a robust hot plug solution, which typically includes:

- Device detection even with power downed receptacles (typical of server applications).
- Pre-charging resistors to passively limit inrush current during drive insertion.
- Hot plug controllers to actively limit inrush current during drive insertion.

## 3.13 Active LED Status

The drive supports external LED requirements. It provides an activity LED output which is ON during command execution and OFF otherwise.

## 3.14 Fluid Dynamic Bearings (FDB)

Bearing design that incorporates a layer of high-viscosity lubricant instead of ball bearings in the hard drive spindle motor. As an alternative to conventional ball bearing technology, FDB designs provide increased non-operational shock resistance, speed control, and improved acoustics.

## 3.15 Staggered Spinup and Activity Indication (SATA Power Pin 11)

*Note:* This feature is available for specific OEM configurations.

SATA device power connector pin 11 is defined as a means by the host to DISABLE staggered spinup and it may also be used by the device to provide the host with an activity indication. According to the SATA spec, "Staggered Spin-up Disable and Activity Signal shall not be enabled at the same time."

### 3.15.1 Staggered Spinup

When multiple disks are installed in an enclosure, it is desirable to provide a simple mechanism by which a subsystem controller can sequence hard drive initialization to minimize the current load presented during power up. Staggered spinup provides this mechanism by preventing the hard drives from spinning up until after successful PHY initialization (i.e., after PHY enters DP7:DR\_Ready state).

Staggered spinup is only applicable during initial power-up. If a drive is spun down using ATA commands—as a result of having been placed in Standby or Sleep power modes, for example—the drive shall spin up following the rules that govern spinup from low power modes described in ATA/ATAPI-6 or later.

### 3.15.2 Activity Indication

The host controller through SATA power pin 11 may access storage device status and activity. The signal provided by the device for activity indication is a low-voltage low-current signal. It is not suitable for directly driving an LED. A buffer circuit external to the device must be employed to drive the LED.

The activity signal is based on an open-collector or open-drain active low driver. The device shall tolerate the activity signal being shorted to ground.

### 3.16 48-bit Logical Block Addressing (LBA)

The 48-bit Address feature set allows devices with capacities up to approximately 281 tera sectors or approximately 144 peta bytes. In addition, the number of sectors that may be transferred by a single command are increased by increasing the allowable sector count to 16 bits.

48-bit Address					
Bits (47:40)	Bits (39:32)	Bits (31:24)	Bits (23:16)	Bits (15:8)	Bits (7:0)
LBA High (exp)	LBA Mid (exp)	LBA Low (exp)	LBA High	LBA Mid	LBA Low

16-bit Sector Count	
Bits (15:8)	Bits (7:0)
Sector Count (exp)	Sector Count

### 3.17 Self-Monitoring, Analysis, and Reporting Technology (S.M.A.R.T.)

S.M.A.R.T. helps you monitor a drive’s internal status through diagnostic commands at the host level.

The drive monitors Read Error Rate, Start/Stop Count, Re-allocated Sector Count, Seek Error Rate, Power-on Hours Count, Spin-up Retry Count, Drive Calibration Retry Count, Drive Power Cycle Count, Offline Scan Uncorrectable Sector Count, Ultra ATA CRC Error Rate, Multi-zone Error Rate, Spin-up Time, Relocation Event Count, and Current Pending Sector Count. The hard drive updates and stores these attributes in the reserved area of the disk. The drive also stores a set of attribute thresholds that correspond to the calculated attribute values. Each attribute threshold indicates the point at which its corresponding attribute value achieves a negative reliability status.

## 3.18 Password Security Mode

The Security Mode feature set allows the user to create a device lock password that prevents unauthorized hard drive access even if the drive is removed from the computer. This feature varies by drive configuration and may not be available on all configurations.

### 3.18.1 Master and User Passwords

The manufacturer/dealer can set a master password using the Security Set Password command, without enabling the device lock function. The user password should be given or changed by a system user.

Master Password Identifier is supported and set to a default value of 00FE. If a Master Password is set via a Security Set Password Command, a valid Master Password Revision code value of 0001h – FFFEh must be used. A Master Password Identifier of 0000h is ignored.

When the master password is set, the drive does *not* enable the device lock function. When the user password is set, the drive enables the device lock function, and the drive is locked after the next power on reset or hard reset.

### 3.18.2 Security Levels

High - If High level security is set and the user password is forgotten, the master password can be used to unlock the drive and access the data.

Maximum - If Maximum level security is set and the user password is forgotten, data access is impossible. Only the master password with a Security Erase Unit command can unlock the drive when the device lock function is enabled and the user password has been forgotten. When the Security Erase Unit command is used to unlock the drive, all user data is erased.

## 3.19 Data Path Protection (DPP)

DPP prevents possible electronic failures from corrupting data on the hard drive. Although typically a very rare occurrence, there is the possibility of intermittent failures within the hard drive due to the electronics or connections on the printed circuit board inducing corruption of the data as it moves from the interface to the media. By incorporating DPP in our hard drives, Western Digital protects customer data with the ability to detect these type of rare events, and prevents incorrect data from being written to the media.

## 3.20 Manufacturing Option Block

The 8-pin jumper block is for factory use only. Placing a jumper on the pins does not enable any features or affect drive setup or performance. Do not place a jumper on these pins.

*Figure 5 Manufacturing Option Block*

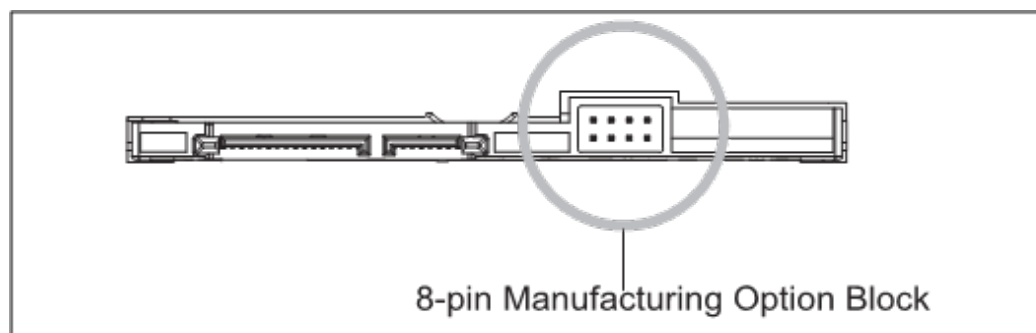

## 4.0 RELIABILITY

### 4.1 Reliability Considerations

The error rates stated in this specification assume the following:

Operation of the drive at the minimum or maximum base casting temperature is intended for short time periods only.

You can enhance the reliability of the Western Digital hard drive by ensuring that the drive receives adequate cooling. “Temperature Measurement” on page.17 Provides temperature measurements and other information that may be used to enhance the service life of the drive. Recommended airflow information is provided in “Cooling” on page.18. The drive incorporates industry standard Self-Monitoring, Analysis and Reporting Technology (SMART).

If the system in which the drive is installed does not meet the characteristics defined in this TRM, please use a Western Digital drive that matches your system's capability.

### 4.2 Error Rates

The error rates stated in this specification assume the following:

- The drive is operated per the DC power specified.
- The drive has been formatted with the FORMAT UNIT command.
- Errors previously detected as caused by media defects are excluded from further error rate computations.
- Random error distribution

#### 4.2.1 Error Rates

Error Rates are specified as based upon ECC On-The-Fly data correction, automatic retries being allowed, and all drive flaws reallocated.

Recoverable Read error rate:	Less than 1 error in $10^{12}$ bits transferred
Unrecoverable Read error rate:	Less than 1 in $10^{15}$ bits transferred
Mis-corrected Read error rate:	Less than 1 sector in $10^{21}$ bits transferred
Interface Error Rate:	Less than 1 error in $10^{12}$ bits transferred

##### 4.2.1.1 Seek Errors

A seek error is defined as a failure to position a head over the addressed track. As stated by the seek error rate above, if the drive detects a seek error it will automatically perform an error recovery procedure. If this error recovery fails, this is deemed an unrecoverable seek error and the drive will report back an '04'h sense key; these errors are classified as a drive failure as defined within our MTBF specification.

### 4.2.1.2 Read Errors

A typical read can return data at a rate as defined in our performance section without additional drive delay. This capability is based upon the LDPC (Low Density Parity Check) Channel technology which provides data with ECC On-The-Fly data correction capability.

Beyond this on-the-fly capability, read errors can occur and are defined as follows:

**Recoverable** – whereby the drives error recovery procedure is required to correctly return the data after an initial error condition was encountered.

**Unrecoverable** – whereby the drives error recovery procedures are unable to correctly return the data requested; this data should be allocated to a new area of the drive.

**Mis-corrected** – as specified in the error rate above the frequency for this type of occurrence is extremely rare. This type of event can occur as it relates to the tradeoffs of the channel technology engine against the quantity, lengths, and patterns of data errors which may occur within a sector. As mentioned above the LDPC channel is required to enable the recoverable and unrecoverable error rates as specified above.

Before measuring read error rates, ensure that:

1. The data that is being used for measurement of read error rates must be verified that it is written correctly on the media.
2. All media defect induced errors must be excluded from error rate calculations.

### 4.2.1.3 Interface Errors

An interface error is defined as when the drive receiver detects errors of the incoming data whereby the drive is unable to recover the data as transmitted to the receiver. These errors can include any of: running disparity errors, illegal code, loss of word sync, or CRC errors.

## 4.2.2 Environmental Interference

When evaluating systems under conditions of EMI, the performance of the drive within the system shall be considered acceptable if the drive does not generate an unrecoverable condition. This unrecoverable condition is defined as one that:

1. Is not detected and corrected by the drive itself.
2. Is not capable of being detected from the error or fault status provided through the drive or its interface.
3. Is not capable of being recovered by normal drives or system recovery methods without operator intervention.

## 4.3 Reliability Features Set

### 4.3.1 Data Lifeguard™\*

Representing the ongoing commitment to data protection, Data Lifeguard includes features that enhance the drive's ability to prevent data loss. Data Lifeguard data protection utilities include thermal management, an environmental protection system, and embedded error detection and repair features that automatically detect, isolate, and repair problem areas that may develop over the extended use of the drive. With these enhanced data reliability features, the drive can perform more accurate monitoring, error repair, and deliver exceptional data security.

### 4.3.2 Thermal Management

The drive is designed with Thermal Management features for high reliability.

- **State-of-the-art mechanical design**—Mechanical design is optimized to reduce the drive's temperature. State-of-the-art thermal dissipation and windage design is employed.
- **Closed loop servo management**—Thermal management monitors the drive temperature and can control servo operations to maintain a stable operating temperature under high temperature conditions. This is a closed loop servo and thermal control system.
- **SMART HDA Temperature Attribute**—The SMART HDA Temperature Attribute is supported.
- **Ducted airflow**—Provides protection to the Read/Write element from heated air.

### 4.3.3 Internal Environmental Protection System

This system protects the inside environment of the drive from contamination. System features include:

- Filtration System to ensure fast clean-up times
- Directed airflow to maximize mechanical cooling
- Increase casting surface area to maximize cooling
- Breather filter located at low pressure area
- Enhanced heat dissipation

### 4.3.4 Defect Management

Every Western Digital drive undergoes factory-level intelligent burn in, which thoroughly tests for and maps out defective sectors on the media before the drive leaves the manufacturing facility. Following the factory tests, a primary defect list is created. The list contains the cylinder, head, and sector numbers for all defects.

Defects managed at the factory are sector slipped. Grown defects that can occur in the field are mapped out by relocation to spare sectors on the inner cylinders of the drive.

### 4.3.5 Recoverable Errors

When a sector is recovered by firmware it is marked as needing repair. When a new host command writes to that sector, a sector test is performed by writing and reading to that location several times. If recovery is required to read the sector during the sector test, it is relocated.

### 4.3.6 Unrecoverable Errors

If an unrecoverable error is found during the offline scan, the sector is marked. Future reads from this location will continue to perform full error recovery. However, the next write to this location will perform a sector test to be sure the media is not damaged, and the sector relocated if the sector test fails.

---

\* Default shipping configuration has Data Lifeguard feature disabled for power management optimization.

### 4.3.7 Automatic Defect Retirement

The automatic defect retirement feature automatically maps out defective sectors while reading or writing. If a defective sector appears, the drive finds a spare sector.

The following are specific to automatic defect retirement on writes (write auto-relocation):

- Data is always written to disk (using automatic defect retirement if required) and no error is reported.
- When host retries are enabled, the drive will internally flag any unrecoverable errors (DAMNF or ECC). This flagging allows subsequent write commands to this location to relocate the sector only if the sector test fails.

### 4.3.8 Error Recovery Process

The drive has five means of error recovery:

- ECC On-the-Fly
- Read/Write Retry Procedure
- Extended Read Retry Procedure

**ECC On-the-Fly** – If an LDPC error occurs, the drive attempts to correct it on-the-fly without retries. Data can be corrected in this manner without performance penalty.

**Read/Write Retry Procedure** – This retry procedure is used by all disk controller error types. If the procedure succeeds in reading or writing the sector being tried, then recovery is complete and the controller continues with the command. Each retry operation also checks for servo errors. The procedure ends when error recovery is achieved or when all possible retries have been attempted.

**Extended Read Retry Procedure** – This retry procedure tries combinations of positive/negative track offsets and data DAC manipulations to recover the data. This retry procedure applies only to read data recovery. The Read/Write Retry procedure performs the actual retry operation.

When an extended retry operation is successful, the controller continues with the command. The controller clears any changes in track offset or data DAC settings before the command continues.

## 5.0 ATA COMMAND SET

### 5.1 Host Interface Commands

#### 5.1.1 ATA- 7/ATA- 8 Commands

Table 6 lists the hexadecimal codes specific to each ATA-7/ATA-8 command supported by these hard drives. Refer to the D1699 ATA8-ACS specification for full details on each command.

*Table 6 ATA-7/ATA-8 Command Opcodes*

COMMAND	HEX OPCODE
CHECK POWER MODE	E5
DOWNLOAD MICROCODE	92
EXECUTE DEVICE DIAGNOSTIC	90
FLUSH CACHE	E7
FLUSH CACHE EXT	EA
IDENTIFY DEVICE	EC
IDLE	E3
IDLE IMMEDIATE	E1
NOP	00
READ BUFFER	E4
READ DMA	C8
READ DMA EXT	25
READ FPDMA QUEUED	60
READ LOG EXT	2F
READ LOG DMA EXT	47
READ MULTIPLE	C4
READ MULTIPLE EXT	29
READ SECTOR(S)	20
READ SECTORS(S) EXT	24
READ VERIFY SECTOR(S) EXT	42
READ VERIFY SECTORS(S)	40
S.M.A.R.T.	B0
SECURITY DISABLE PASSWORD	F6
SECURITY ERASE PREPARE	F3
SECURITY ERASE UNIT	F4
SECURITY FREEZE LOCK	F5
SECURITY SET PASSWORD	F1
SECURITY UNLOCK	F2
SET FEATURES	EF
SET MULTIPLE	C6
SLEEP	E6



COMMAND	HEX OP CODE
STANDBY	E2
STANDBY IMMEDIATE	E0
WRITE BUFFER	E8
WRITE DMA	CA
WRITE DMA EXT	35
WRITE FPDMA QUEUED	61
WRITE LOG EXT	3F
WRITE LOG DMA EXT	57
WRITE MULTIPLE	C5
WRITE MULTIPLE EXT	39
WRITE SECTOR(S)	30
WRITE SECTOR(S) EXT	34
WRITE UNCORRECTABLE EXT	45

### 5.1.2 SATA Commands

Table 7 lists the hexadecimal codes specific to each SATA command supported by these hard drives. Refer to the SATA specification for full details on each command.

*Table 7 Optional Subcommands*

COMMAND	SUBFUNCTION
DOWNLOAD MICROCODE	Mode 3
DOWNLOAD MICROCODE	Mode 7
DOWNLOAD MICROCODE	Mode E
DOWNLOAD MICROCODE	Mode F

### 5.1.3 Obsolete Commands

Table 8 lists the hexadecimal codes specific to each obsolete command supported by these hard drives.

*Table 8 Obsolete Command Opcodes*

COMMAND	HEX OP CODE
SET MAX ADDRESS EXT	37
SET MAX	F9
READ NATIVE MAX ADDRESS EXT	27
DEVICE CONFIGURATION OVERLAY	B1
READ NATIVE MAX ADDRESS	F8
INITIALIZE DEVICE PARAMETERS	91
RECALIBRATE	10
SEEK	70

### 5.1.4 SCT Commands

SCT commands provide capabilities not covered in ATA/ATAPI-7 for commands that do not fit the ATA command delivery model. Some SCT commands report completion when the command begins execution. Execution progress for these commands may be checked by requesting SCT status. For instance, the host can track the progress of a Write Same command by issuing a status request once per minute. See ATA8-ACS for a full description of SCT.

*Table 9 SCT Action Codes*

ACTION CODE	DESCRIPTION
0000h	RESERVED
0001h	Long Sector Access
0002h	Write Same
0004h	Features Control
0005h	SCT Data Tables
0006h	Vendor specific
0007h	SCT BIST
C000h	FFFFh Vendor specific

## 5.2 S.M.A.R.T. (B0h)

The S.M.A.R.T. command provides access to attribute values, S.M.A.R.T. status, and other S.M.A.R.T. information. These commands can be used for logging and reporting purposes, and for accommodating special user needs.

Prior to writing the S.M.A.R.T. command to the Command Register, the host must write key values into the LBA Mid and LBA High Registers (4Fh, C2h) or the command will be aborted and an error will be reported.

The S.M.A.R.T. command has several sub-commands that are selectable via the Features Register when the host issues the S.M.A.R.T. command. To select a sub-command, the host must write the appropriate sub-command code to the Features Register before issuing the S.M.A.R.T. command. The sub-commands and their respective codes are listed below. For more detailed information on executing

S.M.A.R.T. commands, see the ATA-7 specification.

### 5.2.1 Read Attribute Values Sub- Command

This command returns a sector of data with the drive's S.M.A.R.T. data structure.

Table 10 Definitions for the 512 Bytes.

BYTE	VALUE	DESCRIPTION
0 - 1	0010h	S.M.A.R.T. Data Structure Revision
2 -361	XX	S.M.A.R.T. Attribute Data
135 - 361	XX	S.M.A.R.T. Attribute Data
362	XX	Offline data collection status 0Xh OL disabled 8Xh OL enabled X0h scan not run X2h scan complete X4h scan suspended X5h scan aborted
363	XX	Self-Test execution status byte. 00h The previous self-test routine completed without error or no self-test has ever been run 01h The self-test routine was aborted by the host 02h The self-test routine was interrupted by the host with a hard or soft reset
<b>BYTE</b>	<b>VALUE</b>	<b>DESCRIPTION</b>
		03h A fatal error or unknown test error occurred while the device was executing its self-test routine. The device was unable to complete the self-test routine.
		04h The previous self-test completed having a test element that failed. The test element that failed is not known.
		05h The previous self-test completed having a test element that failed. The electrical element of the test failed.
		06h The previous self-test completed having a test element that failed. The servo (and/or seek) test element of the test failed.
		07h The previous self-test completed having a test element that failed. The read element of the test failed.
		08h The previous self-test completed having a test element that failed. The element damage is suspected to be caused by handling.
		09-0Fh Reserved 0Eh Self-test routine in progress
364 - 365	XX	Total time in seconds to complete offline data collection activity
366	XX	Reserved
367	07Bh	Offline data collection capability. Bits are as follows: 0 1 = Offline Immediate Command supported 1 1 = Auto Offline enable\disable command supported 2 0 = Offline will suspend on and will resume after host command 3 1 = Offline read scan implemented 4 1 = DST Short and Extended tests supported 5 1 = DST Conveyance test supported 6-7 0 - Reserved
368 - 369	0003h	S.M.A.R.T. Capability. Bits are as follows: 0 1 = The device saves SMART data prior to going into a power saving mode 1 1 = Device complies with SMART data autosave after an event 2-15 Reserved

370	01h	Error logging capability. Bits are as follows: 0 1 = Error logging supported 1 Reserved
371	XX	Reserved
372	XX	Short self-test routine completion time in minutes
373	XX	Extended self-test routine completion time in minutes
374	XX	Conveyance self-test routine completion time in minutes
375 - 510	XX	Reserved
511	XX	Checksum

### 5.2.2 Supported Attributes

The drive supports the following attributes.

Table 11 Supported Attributes

Attribute	Attribute ID Number	Pre-Failure/Advisory Bit (Status Flags bit 0) <sup>1</sup>
Read Error Rate	1	Pre-Failure
Spin-up Time	3	Pre-Failure
Start/Stop Count	4	Advisory
Re-allocated Sector Count	5	Pre-Failure
Seek Error Rate	7	Advisory
Power-on Hours Count	9	Advisory
Spin-up Retry Count	10	Advisory
Drive Calibration Retry Count	11	Advisory
Drive Power Cycle Count	12	Advisory
Gas Gauge	16	Advisory
Emergency Retract Cycles	192	Advisory
Load/Unload Cycles	193	Advisory
HDA Temperature <sup>2</sup>	194	Advisory
Relocation Event Count	196	Advisory
Current Pending Sector Count	197	Advisory
Offline Scan Uncorrectable Sector Count	198	Advisory
Ultra DMA CRC Error Rate	199	Advisory
Multi-zone Error Rate	200	Advisory
<sup>1</sup> Status bits are typical but may vary.		
<sup>2</sup> See "Temperature Reporting" on page 24 for a better mechanism.		

Attributes that use the Pre-Failure/Advisory Bit Set can predict potential future degrading or faulty conditions. Attributes with the Failure/Advisory Bit Clear are used for informational purposes only, they do not indicate impending drive failure.

The S.M.A.R.T. data saving process is a background task. After a pre-determined idle period, the self-monitoring data is automatically saved to the disk.

### 5.2.3 Read Log Sector

There are several logs that can be read with the S.M.A.R.T. Read Log Sector sub-command. The LBA Low Register indicates the log sector to be returned.

Table 12 Log Address Definition

Log Address	Log Name	Feature Set	R/W	Access
00h	Log directory	ExtLog	RO	GPL, SL
01h	Summary Log	SMART	RO	SL
02h	Comprehensive SMART error log	SMART	RO	SL
03h	Extended Comprehensive SMART error log	ExtLog	RO	GPL
04h	Device Statistics	N/A	RO	GPL, SL
05h	Reserved	Reserved	Reserved	
06h	SMART self-test log	SMART	RO	SL
07h	Extended SMART self-test log	ExtLog	RO	GPL
08h	Reserved	Reserved	Reserved	
09H	Selective self-test log	SMART	R/W	SL
0Ah-0Fh	Reserved	N/A	Reserved	
10h	NCQ Command Error	NCQ	RO	GPL
11h	SATA PHY Counters	ExtLog	RO	GPL
12h-17h	Reserved for Serial ATA	N/A	Reserved	
18h-1Fh	Reserved	N/A	Reserved	
20h	Obsolete			
21h	Write Stream Error Log	Streaming	RO	GPL
22h	Read Stream Error Log	Streaming	RO	GPL
23h	Obsolete			
24h-7Fh	Reserved	N/A	Reserved	
80h-9Fh	Host vendor specific	SMART / ExtLog	R/W	GPL, SL
A0h-BFh	Device vendor specific	SMART / ExtLog	VS	GPL, SL
C0h-EFh	Reserved	Reserved	Reserved	
E0h	SCT Command/Status	N/A	R/W	GPL, SL
E1h	SCT Data Transfer			GPL, SL
E2h-FFh	Reserved	Reserved	Reserved	

RO – Read Only  
R/W – Read / Write  
SMART – Supported by B0h command code.  
ExtLog – Supported by 2Fh/3Fh command code. VS – Vendor Specific  
SCT – SMART Command Transport

### 5.3 Identify Device (ECh)

The Identify Device command transfers 512 bytes of data that specify the drive’s parameters. Table 5-8 lists the parameters read by the host

Table 13 Identify Device Command

WORD	FIELD DESCRIPTION	POWER- ON DEFAULT VALUE
0	General Configuration	427Ah
1	Obsolete	3FFFh
2	Specific Configuration	C837h
3	Obsolete	0010h
4-5	Retired	0000h
6	Obsolete	003Fh
7-8	Reserved for assignment by the CompactFlash™ Association	0000h
9	Retired	0000h
10-19	Serial Number (ATA String)	nnnnnnnn
20-21	Retired	0000h
22	Obsolete	0000h
23-26	Firmware Revision (ATA String)	“nnnnnnn”
27-46	Model Numbers (ATA String)	“HGST HUS722T2TALA604” “HGST HUS722T1TALA604”
47	READ/WRITE MULTIPLE support Bit 15-8: 80h Bit 7-0: 00h: Reserved 01h-FFh = Maximum number of logical sectors that shall be transferred per DRQ data block on READ/WRITE MULTIPLE commands	8010h
48	Trusted Computing feature set options Bit 15: Shall be cleared to zero Bit 14: Shall be set to one Bit 13-1: Reserved for the Trusted Computing Group Bit 0: If set, Trusted Computing feature set is supported	4000h
49	Capabilities Bit 15-14: Reserved for the IDENTIFY PACKET DEVICE command. Bit 13: If set, Standby timer values as specified in this standard are supported. 0 = Standby timer values shall be managed by the device Bit 12: Reserved for the IDENTIFY PACKET DEVICE command Bit 11: If set, IORDY supported Bit 10: If set, IORDY may be disabled Bit 9: If set, LBA supported Bit 8: If set, DMA supported Bit 7-2: Reserved Bit 1: Current Long Physical Alignment Setting	2F00h
50	Capabilities Bit 15: Shall be cleared to zero. Bit 14: Shall be set to one. Bit 13-2: Reserved. Bit 1: Obsolete Bit 0: Shall be set to one to indicate a device specific Standby timer value minimum	4001h
51-52	Obsolete	0000h

53	<p>Additional Words Valid                      Bit 8-15: Free-fall Control Sensitivity                      00h = Vendor's recommended setting                      01h-FFh = Sensitivity level. A larger number is a more sensitive setting.                      Bit 7-3: Reserved                      Bit 2: If set, the fields reported in word 88 are valid                      Bit 1: If set, the fields reported in words 70-64 are valid Bit 0: Obsolete</p>	0007h
54-58	Obsolete	3FFF 0010 003F FC10 00FB
59	<p>Current Blocking Factor                      Bit 15: 1=The BLOCK ERASE EXT command is supported Bit 14: 1= The OVERWRITE EXT command is supported Bit 13: 1=The CRYPTO Scramble EXT command is supported                      Bit 12: 1=The Sanitize feature set is supported Bit 9-11 Reserved                      Bit 8: 1=Multiple local sector setting is valid                      Bit 0-7: Current setting for number of logical sectors that shall be transferred per DRQ data block on READ/WRITE Multiple commands</p>	0100h
60-61	Total number of user addressable logical sectors for 28 bit commands (DWord)	0FFFFFFFh
62	Obsolete	0000h
63	<p>Multi-Word DMA Transfer Mode Supported Bit 15-11: Reserved                      Bit 10: If set, Multiword DMA mode 2 is selected                      Bit 9: If set, Multiword DMA mode 1 is selected Bit 8: If set, Multiword DMA mode 0 is selected Bit 7-3: Reserved                      Bit 2: If set, Multiword DMA mode 2 Bit 1: If set, Multiword DMA mode 1 Bit 0: If set, Multiword DMA mode 0</p>	0107h
64	Advanced PIO Modes Supported Bits 0-7: PIO Modes supported	0003h
65	Min. Multi-Word DMA Transfer Cycle Time (ns) Bit 15-0: Cycle time in nanoseconds	0078h
66	Manufacturer Recommended Multi-Word DMA Cycle Time Bit 15-0: Cycle time in nanoseconds	0078h
67	Min. PIO Transfer Cycle Time without flow control Bit 15-0: Cycle time in nanoseconds	0078h
68	Min. PIO Transfer Cycle Time with IORDY flow control Bit 15-0: Cycle time in nanoseconds	0078h
69	<p>Additional Supported                      Bit 15: If set, CFAST Specification Support                      Bit 14: If set, Deterministic data in trimmed LBA range(s) is supported                      Bit 13: If set, Long Physical Sector Alignment Error Reporting Control is supported                      Bit 12: If set, DEVICE CONFIGURATION IDENTIFY DMA and DEVICE CONFIGURATION SET DMA are supported Bit 11: If set, READ BUFFER DMA is supported                      Bit 10: If set, WRITE BUFFER DMA is supported                      Bit 9: If set, SET MAX SET PASSWORD DMA and SET MAX UNLOCK DMA are supported                      Bit 8: If set, DOWNLOAD MICROCODE DMA is supported Bit 6: If set, Optional ATA device 28-bit commands supported                      Bit 7: If set, Reserved for IEEE 1667                      Bit 5: If set, Trimmed LBA range(s) returning zeroed data is supported                      Bit 4: If set, Device Encrypts All User Data                      Bit 3: If set, Extended Number of User Addressable Sectors is supported                      Bit 2-0: Reserved</p>	0D00h
70	Reserved	0000h
71-74	Reserved for the Identify Packet Device command	0000h

75	Queue Depth Bit 15-5: Reserved Bit 4-0: Maximum queue depth - 1	001Fh
76	Serial ATA Capabilities Bit 15-13: Reserved Bit 12: If set, supports Native Command Queuing priority information Bit 11: If set, supports Unload while NCQ commands outstanding Bit 10: If set, supports Phy event counters Bit 9: If set, supports receipt of host-initiated interface power management requests Bit 8: If set, supports Native Command Queuing (NCQ) Bit 7-3: Reserved for future Serial ATA signaling speed grades Bit 2: If set, supports Serial ATA Gen2 signaling speed (3 Gb/s) Bit 1: If set, supports Serial ATA Gen1 signaling speed (1.5 Gb/s) Bit 0: Shall be cleared to zero	9F0Eh
77	Serial ATA Additional Capabilities Bit 15-8: Reserved Bit 7: If set, Supports DevSleep to ReducedPwrState Bit 6: If set, Supports Supports RECEIVE FPDMA QUEUED and SEND FPDMA QUEUED commands Bit 5: If set, Supports NCQ NON-DATA Command Bit 4: If set, Supports NCQ Streaming Bit 3-1: Coded value indicating current negotiated Serial ATA signal speed Bit 0: Shall be cleared to zero	0004h
78	Serial ATA Features Supported Bits 15-7: Reserved for Serial ATA Bit 6: If set, device supports software settings preservation Bit 5: Reserved for Serial ATA Bit 4: If set, device supports in-order data delivery Bit 3: If set, device supports initiating power management Bit 2: If set, device supports DMA Setup Auto-activation Bit 1: If set, device supports non-zero buffer offsets Bit 0: Cleared to zero	004Ch
79	Serial ATA Features Enabled Bits 15-7: Reserved for Serial ATA Bit 6: If set, software settings preservation enabled Bit 5: Reserved for Serial ATA Bit 4: If set, In-order data delivery enabled Bit 3: If set, device initiated power management enabled Bit 2: If set, DMA Setup Auto-activation enabled Bit 1: If set, non-zero buffer offsets enabled Bit 0: Cleared to zero	0040h
80	Major Version Number Bits 15-10: Reserved Bit 9: if set, supports ACS-2 Bit 8: if set, supports ATA8-ACS Bit 7: if set, supports ATA/ATAPI-7 Bit 6: if set, supports ATA/ATAPI-6 Bit 5: if set, supports ATA/ATAPI-5 Bit 4 –1: Obsolete Bit 0: Reserved	03FEh
81	Minor Version Number	001Fh
82	Command and feature sets supported Bit 14: If set, NOP command supported Bit 13: If set, Read buffer command supported Bit 12: If set, Write buffer command supported Bit 11: Obsolete Bit 10: If set, Host Protected Area Feature Set supported Bit 9: If set, Device Reset command supported Bit 8: If set, Service interrupt supported Bit 7: If set, Release interrupt supported Bit 6: If set, look-ahead supported Bit 5: If set, Write Cache supported Bit 4: Cleared to 0 to indicate that the PACKET feature set is not supported. Bit 3: If set, mandatory Power Management Feature Set supported Bit 2: Obsolete Bit 1: If set, Security Feature Set supported Bit 0: If set, SMART Feature Set supported	706Bh
83	Command Set Supported Bit 15: Shall be cleared to 0 Bit 14: Shall be set to 1 Bit 13: If set, Flush Cache EXT command supported Bit 12: If set, mandatory Flush Cache command supported Bit 11: If set, DCO feature set supported Bit 10: If set, 48-bit Address Feature Set supported Bit 9: Not supported Bit 8: If set, Set Max Security Extension supported Bit 7: Reserved Bit 6: If set, Set Features subcommand required to spin-up after power-up Bit 5: If set, Power-Up In Standby feature set supported Bit 4: Obsolete Bit 3: If set, Advanced Power Management feature set supported Bit 2: If set, CFA feature set supported Bit 1: If set, Read/Write DMA Queued supported Bit 0: If set, Download Microcode command supported	7469h



84	<p>Command and feature sets supported Bit 15: Shall be cleared to zero                  Bit 14: Shall be set to one                  Bit 13: If set, Idle Immediate with Unload Feature supported Bit 12: Reserved                  Bit 11: Reserved                  Bit 9-10: Obsolete                  Bit 8: If set, 64-bit World wide name supported                  Bit 7: If set, Write DMA Queued FUA EXT command supported                  Bit 6: If set, Write DMA FUA EXT and Write Multiple FUA EXT commands supported                  Bit 5: If set, General Purpose Logging feature set supported Bit 4: If set, Streaming Feature Set supported                  Bit 3: Obsolete                  Bit 2: If set, Media serial number supported Bit 1: If set, SMART Self-Test supported                  Bit 0: If set, SMART Error Logging supported</p>	6163h
85	<p>Command and feature sets supported or enabled Bit 15: Obsolete                  Bit 14: If set, NOP command supported                  Bit 13: If set, Read Buffer command supported Bit 12: If set, Write Buffer command supported Bit 11: Obsolete                  Bit 10: If set, Host Protected Area has been established Bit 9: If set, DEVICE RESET command supported                  Bit 8: If set, SERVICE interrupt enabled Bit 7: If set, Release Interrupt enabled Bit 6: If set, Read look-ahead enabled                  Bit 5: If set, Volatile Write cache enabled                  Bit 4: Cleared to 0 to indicate that the PACKET feature set is not supported                  Bit 3: Set to 1 to indicate that the Mandatory Power Management feature set is supported                  Bit 2: Obsolete                  Bit 1: If set, Security Feature Set enabled Bit 0: If set, SMART Feature Set enabled</p>	7069h
86	<p>Commands and feature sets supported or enabled Bit 15: If set, Words 119-120 are valid                  Bit 14: Reserved                  Bit 13: If set, Flush Cache EXT command supported Bit 12: If set, Flush Cache command supported                  Bit 11: If set, Device Configuration Overlay supported Bit 10: If set, 48-bit Address Feature Set supported Bit 9: Not supported                  Bit 8: If set, Set Max Security Extension enabled by Set Max Set Password                  Bit 7: Reserved                  Bit 6: If set, Set Features subcommand required to spin-up after power-up                  Bit 5: If set, Power-Up In Standby feature set enabled Bit 4: Obsolete                  Bit 3: If set, Advanced Power Management feature set enabled                  Bit 2: If set, CFA Feature Set enabled                  Bit 1: If set, Read/Write DMA Queued command supported Bit 0: If set, Download Microcode command supported</p>	B449h
87	<p>Commands and feature sets supported or enabled Bit 15: Shall be cleared to zero                  Bit 14: Shall be set to 1                  Bit 13: If set, Idle Immediate with Unload Feature supported Bit 12: Reserved                  Bit 11: Reserved                  Bit 9-10: Obsolete                  Bit 8: If set, 64-bit World wide name supported Bit 7: Obsolete                  Bit 6: If set, Write DMA FUA EXT and Write Multiple FUA EXT commands supported                  Bit 5: If set, General Purpose Logging Feature Set supported                  Bit 4: Obsolete                  Bit 3: Obsolete                  Bit 2: If set, Media serial number is valid Bit 1: If set, SMART Self-Test supported                  Bit 0: If set, SMART Error Logging supported</p>	6163h
88	<p>Ultra DMA modes Bit 15: Reserved                  Bit 14: If set, Ultra DMA Mode 6 is selected                  Bit 13: If set, Ultra DMA Mode 5 is selected Bit 12: If set, Ultra DMA Mode 4 is selected Bit 11: If set, Ultra DMA Mode 3 is selected Bit 10: If set, Ultra DMA Mode 2 is selected Bit 9: If set, Ultra DMA Mode 1 is selected Bit 8: If set, Ultra DMA Mode 0 is selected Bit 7: Reserved                  Bit 6: Ultra DMA mode 6 supported Bit 5: Ultra DMA mode 5 supported Bit 4: Ultra DMA mode 4 supported Bit 3: Ultra DMA mode 3 supported Bit 2: Ultra DMA mode 2 supported Bit 1: Ultra DMA mode 1 supported Bit 0: Ultra DMA mode 0 supported</p>	007Fh
89	<p>Bit 15: 1=Extended Time is reported in bits 14:0 0=Time is reported in bits 7:0 and bits 14:8 are reserved                  Bits 14-8: Extended Time required for Normal Erase mode SECURITY ERASE UNIT command                  Bits 7-0: Time required for Normal Erase mode SECURITY ERASE UNIT command</p>	818Ah

90	Bit 15: 1=Extended Time is reported in bits 14:0 0=Time is reported in bits 7:0 and bits 14:8 are reserved Bits 14-8: Extended Time required for Enhanced Erase mode SECURITY ERASE UNIT command Bits 7-0: Time required for Enhanced Erase mode SECURITY ERASE UNIT command	818Ah
91	Current APM level value	0080h
92	Master Password Identifier	FFFEh
93	Hardware reset result	0000h
94	Obsolete	0000h
95	Stream Minimum Request Size	0000h
96	Stream Transfer Time - DMA	0000h
97	Stream Access Latency -DMA and PIO	0000h
98-99	Stream Performance Granularity (Dword)	0000h
100-103	Total number of User Addressable Logical Sectors (QWord)	See "SPECIFICATION" on page.9
104	Streaming Transfer Time - PIO	0000h
105	Maximum number of 512 byte blocks per Data Set Management command	0000h
106	Physical sector size / logical sector size Bit 15 Shall be cleared to zero Bit 14 Shall be set to one Bit 13 if set, Device has multiple logical sectors per physical sector. Bit 12 if set, Device Logical Sector longer than 256 Words Bits 11-4 Reserved Bits 3-0 2 <sup>X</sup> logical sectors per physical sector	6003h
107	Inter-seek delay for ISO 7779 standard acoustic testing	0000h
108-111	World Wide Name	XXXXXXXXXXXXXXXXXX
112-115	Reserved	0000h
116	Reserved for TLC	0000h
117-118	Logical Sector size (DWord)	0000h
119	Commands and feature sets supported (Continued from words 82-84) Bit 15: Cleared to zero Bit 14: Shall be set to one Bit 13-8: Reserved Bit 7: If set, Extended Power Conditions feature set supported Bit 6: If set, Sense Data Reporting supported Bit 5: If set, Free-fall Control feature set is supported Bit 4: If set, DOWNLOAD MICROCODE with offsets is supported Bit 3: If set, READ and WRITE DMA EXT GPL optional commands are supported Bit 2: If set, WRITE UNCORRECTABLE EXT is supported Bit 1: If set, Write-Read-Verify feature set is supported Bit 0: Reserved for DDT	4098h
120	Commands and feature sets supported (Continued from words 85-87) Bit 15: Cleared to zero Bit 14: Shall be set to one Bit 13-8: Reserved Bit 7: If set, Extended Power Conditions feature set supported Bit 6: If set, Sense Data Reporting supported Bit 5: If set, Free-fall Control feature set is supported Bit 4: If set, DOWNLOAD MICROCODE with offsets is supported Bit 3: If set, READ and WRITE DMA EXT GPL optional commands are supported Bit 2: If set, WRITE UNCORRECTABLE EXT is supported Bit 1: If set, Write-Read-Verify feature set is supported Bit 0: Reserved for DDT	4018h
121-126	Reserved	0000h
127	Obsolete	0000h

128	Security Status Bit 15-9: Reserved Bit 8: Security level (0 = High, 1 = Maximum) Bit 7-6: Reserved Bit 5: If set, Enhanced Security Erase supported Bit 4: If set, Security count expired Bit 3: If set, Security Frozen Bit 2: If set, Security Locked Bit 1: If set, Security enabled Bit 0: If set, Security supported	0021hb
129-159	Vendor Specific	xxxxh
160	CFA power mode Bit 15: Word 160 supported Bit 14: Reserved Bit 13: CFA power mode Bit 12: CFA power mode 1 disable Bit 11-0: Maximum current in ma	0000h
161-167	Reserved for the CompactFlash™ Association	0000h
168	Device Nominal Form Factor Bit 15-4: Reserved Bit 3-0: Device Nominal Form Factor	0000h
169	Data Set Management Command Bit 15-1: Reserved Bit 0: if set, the Trim bit in the Data Set Management command supported	0000h
170-173	Additional Product Identifier	0000h
174-175	Reserved	0000h
176-205	Current Media Serial number	0000h
206	SCT Command Transport Bit 15-12: Vendor Specific Bit 11-6: Reserved Bit 5: If set, SCT Data tables command supported Bit 4: If set, SCT Features Control command supported Bit 3: If set, SCT Error Recovery Control command supported Bit 2: If set, SCT Write Same command supported Bit 1: If set, Obsolete Bit 0: If set, SCT Command Transport supported	30BDh
207-208	Reserved	0000h
209	Alignment of logical blocks within a physical block Bit 15: Shall be cleared to zero Bit 14: Shall be set to one Bits 13-0: Logical sector offset within the first physical sector where the first logical sector is placed.	4000h
210-211	Write-Read-Verify Sector Count Mode 3	0000h
212-213	Write-Read-Verify Sector Count Mode 2	0000h
214	NV Cache Capabilities Bit 15-12: NV Cache feature set version Bit 11-8: NV Cache Power Mode feature set version Bit 7-5: Reserved Bit 4: If set, NV Cache feature set enable Bit 3-2: Reserved Bit 1: If set, NV Cache Power Mode feature set enable Bit 0: if set, NV Cache Power Mode feature set supported	0000h
215-216	NV Cache Size in Logical Blocks	0000h
217	Nominal media rotation rate	0000h
218	Reserved	0000h
219	NV Cache Options Bit 15-8: Reserved Bit 7-0: Device Estimate Time to spin up in seconds	0000h
220	Bit 15-8: Reserved Bit 7-0: Write-Read-Verify feature set current mode	0000h
221	Reserved	0000h
222	Transport major version number 0000h or FFFFh=device does not report version Bit 12-15: Transport Type (0h=Parallel 1h=Serial 2h- Fh=Reserved) Bit 6-11: Reserved (Parallel, Serial) Bit 5: Reserved SATA Rev. 3.0 Bit 4: Reserved SATA Rev. 2.6 Bit 3: Reserved SATA Rev. 2.5 Bit 2 : Reserved SATA II: Extensions Bit 1: ATA/ATAPI-7 SATA 1.0a Bit 0: ATA8-APT ATA8-AST	103Eh
223	Transport minor version number	0000h

224-229	Reserved	0000h
230-233	Extended Number of User Addressable Sectors (Qword)	0000h
234	Minimum number of 512-byte data blocks per DOWNLOAD MICROCODE command for mode 03h	0001h
235	Maximum number of 512-byte data blocks per DOWNLOAD MICROCODE command for mode 03h	1000h
236-254	Reserved	0000h
255	Integrity Word Bit 15-8: Checksum Bit 7-0: Signature	XXA5h

## 5.4 Set Features (EFh)

The Set Features command enables or disables the features listed in the following table.

FUNCTION	FEATURES REGISTER	SECTOR COUNT REGISTER
Enable read cache <sup>1</sup>	AAh	Don't care
Disable read cache <sup>1</sup>	55h	Don't care
Enable write cache <sup>1</sup>	02h	Don't care
Disable write cache <sup>1</sup>	82h	Don't care
Set Transfer Mode	03h	Don't care
Enable use of Serial ATA Feature	10h	02h-DMA Setup FIS Auto-Activate optimization 06h-Software Settings
Disable use of Serial ATA Feature	90h	02h-DMA Setup FIS Auto-Activate optimization 06h-Software Settings

<sup>1</sup> Changes are only valid while power remains applied to the drive. After power is cycled, the drive reverts to the default settings.

## 6.0 DRIVE HANDLING AND MAINTENANCE

Hard drives are precision instruments that must be handled with care to prevent damage. It is important to understand that drives are typically damaged because of Electrostatic Discharge (ESD), rough handling, or shock and vibration.

Refer to <https://www.wdc.com/support/hard-drive-support/warranty-returns> for detailed instructions on all phases of repackaging the drive.

**Important:** If your system does not support hot plugging (see “Hot Plug Support” on page 25), it must be turned off and unplugged before installing your hard drive.

### 6.1 Unpacking

#### 6.1.1 Handling Precautions

Western Digital products are designed to withstand normal handling during unpacking and installation. Take care to avoid excessive mechanical shock or electrostatic discharge (ESD), which can permanently damage the hard drive and void the warranty. Hard drives are typically damaged because of ESD, rough handling, or shock and vibration.

To avoid ESD problems, wear a properly grounded wrist strap when handling the hard drive. Articles of clothing generate static electricity. Do not allow clothing to come in direct contact with the hard drive or circuit board components.

When the Western Digital drive is not in its shipping container or installed in its proper host enclosure, it must remain in the antistatic bag. To prevent damage, do not unpack your Western Digital drive until you are ready to install it.

#### 6.1.2 Inspection of Shipping Container

Carefully examine the container for obvious shipping damage, such as: holes, signs of crushing, or stains. Notify the carrier and your Western Digital representative if you observe any shipment damage. Always move the shipping container in the upright position indicated by the arrows on the container.

#### 6.1.3 Removal From Shipping Container

Remove the Western Digital drive from the shipping container only for inspection or installation. Carefully open the box. When removing the Western Digital drive from the box, follow these precautions:

- Grasp the drive by the sides only; avoid touching the circuit board components.
- Gently place the drive on its antistatic bag on a clean, level, grounded work area.
- Do not stack drives or stand the Western Digital drive on its edge.

**CAUTION:** When removing the drive from the shipping container, be careful not to drop it. Dropping the drive can severely damage the head disk assembly or printed circuit board.

### 6.1.4 Removal From Static Shielding Bag

Before removing the drive from its static shielding bag:

- Make sure that your work station is properly grounded.
- Wear a properly grounded wrist strap with good skin contact.
- Avoid contact with any component on the printed circuit board.

After attaching your wrist strap, gently remove the drive from the static shielding bag.

- Handle the drive by the sides only; avoid touching the printed circuit board.
- Handle the drive with the printed circuit board facing downward during installation.
- Do not open the drive's sealed compartment or remove the seals or any labels from the drive; this will void the warranty.

### 6.1.5 Moving Precautions

If you need to move your computer, turn off the power to automatically unload the heads. This helps protect the media and the heads from accidental damage due to vibration, moving, or shipping.

## 6.2 Hard Drive Installation

If your system does not support hot plugging (see “Hot Plug Support” on page.25), it must be turned off and unplugged before installing your hard drive. This avoids the possibility of reversing the polarity of the power connections and eliminating current surges that can damage either the drive or computer. Attach the SATA power supply cable to the SATA device plug power connector. Both the SATA power and signal connector are keyed to ensure proper insertion.

*Figure 6 SATA Cable Connections*

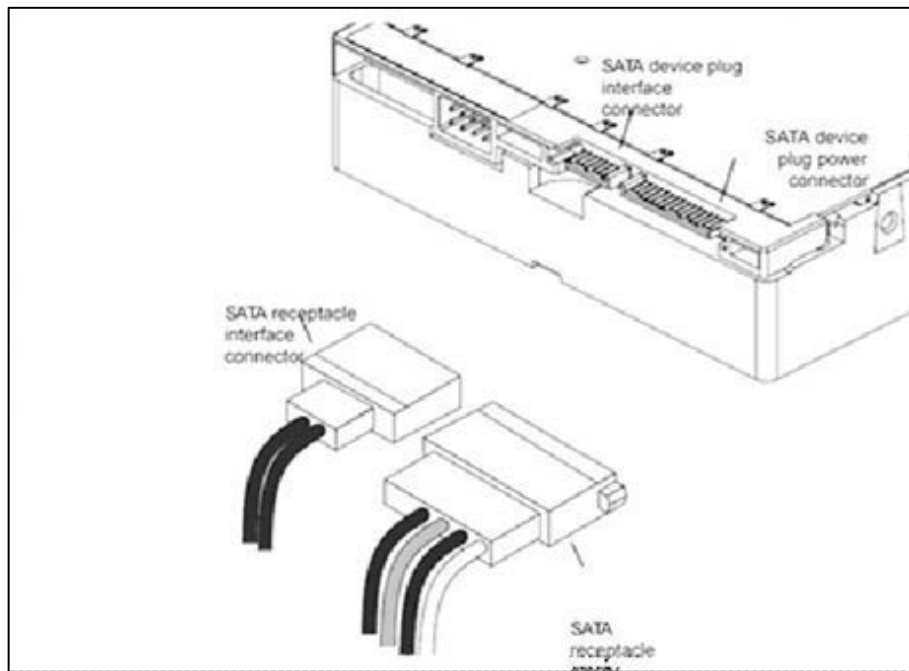

### 6.2.1 Backplane Usage

- The maximum allowable blind-mate tolerance is  $\pm 1.50$  mm in the X-axis.
- The maximum allowable blind-mate tolerance is  $\pm 1.00$  mm in the Z-axis.
- The above tolerances are based on the X-Y plane being perpendicular to Y-Z plane.

See Figure 7 and Figure 8 for the industry-standard connector pin dimensions and references.

Figure 7 Connector Pair Blind Mate Misalignment Allowable

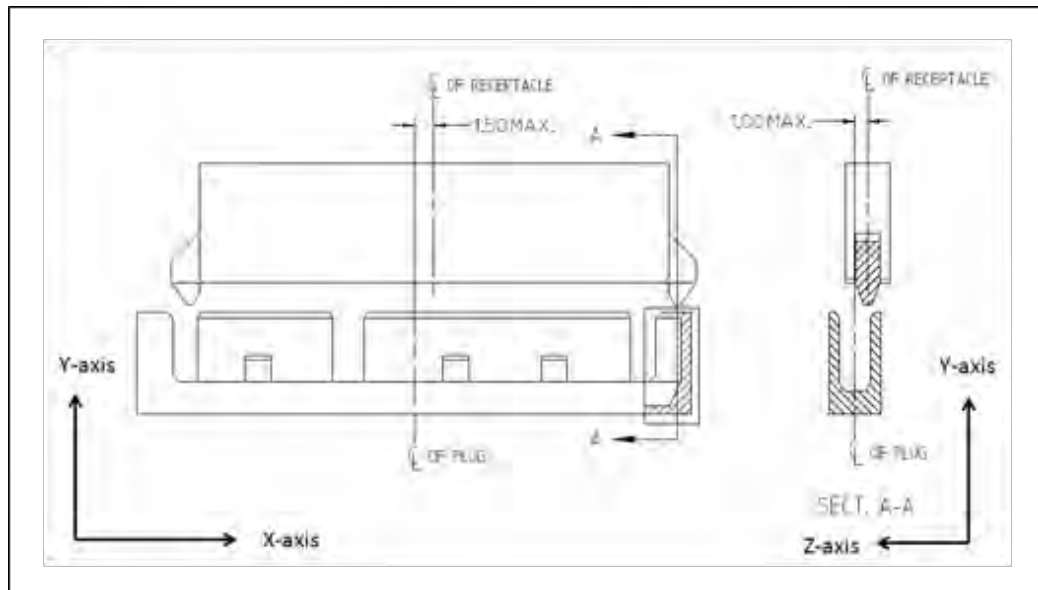
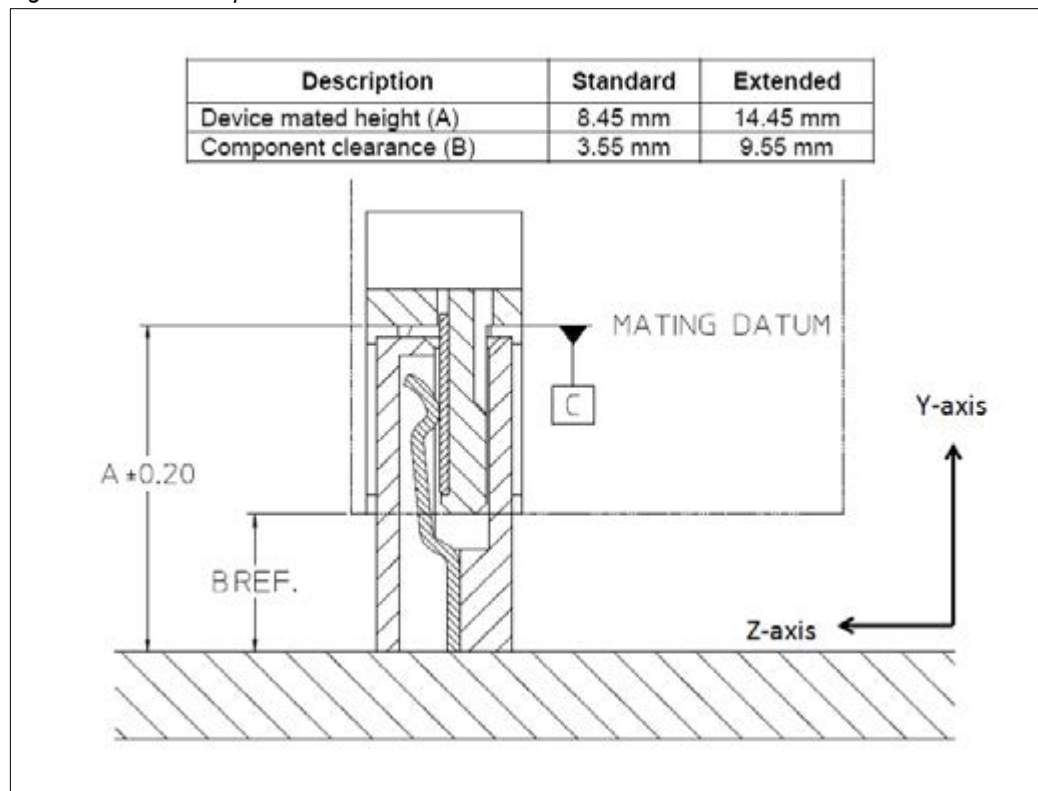

Figure 8 Device Backplane Connection



## 6.3 Maintenance

The hard drive requires no preventative maintenance and contains no user-serviceable parts. The service and repair of drives can only be performed at a Western Digital Service Center. Please contact your Western Digital representative for warranty information and service/return procedures.

Observe the following precautions to prolong the life of the drive:

- Do not attempt to open the sealed compartment of the drive as this will void the warranty.
- Do not lift a drive by the printed circuit board.
- Avoid static discharge when handling a drive.
- Avoid harsh shocks or vibrations.
- Do not touch the components on the printed circuit board.
- Observe the environmental limits specified for this product.
- If it becomes necessary to move your computer system, turn off the power to automatically unload the heads. This helps protect the media and the heads from accidental damage due to vibration while moving or shipping.
- To protect your data, back it up regularly. Western Digital assumes no responsibility for loss of data. For information about back-up and restore procedures, consult your operating system manual. There are also a number of utility programs available that you can use to back up your data.



## 7.0 GLOSSARY

**Active LED Status** — The drive supports external LED requirements. It provides an activity LED output which is ON during command execution and OFF otherwise.

**Annualized Failure Rate (AFR)** — A method of measuring failure rates or trends for a group of units at a site. The rates are based on the monthly total number of returned field failure units divided by the total cumulative installed base and multiplied by 12 (to annualize the failure rate).

**Automatic Defect Retirement** — If defective sectors are found during a read or write, they are automatically mapped out and relocated.

**Block** — A group of bytes handled, stored, and accessed as a logical data unit, such as an individual file record.

**Buffer** — A temporary data storage area that compensates for a difference in data transfer rates and/or data processing rates between sender and receiver.

**Data Lifeguard™** — Representing the ongoing commitment to data protection, Data Lifeguard data protection utilities include thermal management, an environmental protection system, and embedded error detection and repair features that automatically detect, isolate, and repair problem areas that may develop over the extended use of the hard drive.

**Data Transfer Rate** — The rate that digital data is transferred from one point to another, expressed in bits per second or bytes per second. Data Transfer Rate to Disk: The internal disk transfer rate in Mbits per second. Data Transfer Rate from the Buffer to the Host: Based on the transfer of buffered data in MB per second.

**Defect Management** — A general methodology of eliminating data errors on a recording surface by mapping out known bad areas of the media.

**Data Path Protection (DPP)** — A feature that prevents possible electronic failures by preventing corruption of data on the hard drive.

**Dual Stage Actuator (DSA)** — DSA is an improvement to the overall capability of the Servo system and provides a mechanical benefit to improve the response time (higher Bandwidth capability) of moving and maintaining the head position over the data tracks.

**ECC On-the-Fly** — Western Digital utilizes an LDPC hardware correction technique that corrects errors prior to host transfer without any performance penalties. These error corrections are invisible to the host system because they do not require assistance from the drive's firmware.

**Error Correction Code (ECC)** — A mathematical algorithm utilizing LDPC technology that can detect and correct errors in a data field by adding check bits to the original data.

**F.I.T. (Functional Integrity Testing)** — A suite of tests Western Digital performs on all its drive products to ensure compatibility with different hosts, operating systems, application programs, and peripherals. This testing must be performed before the product can be released to manufacturing.

**Fluid Dynamic Bearings (FDB)** — Bearing design that incorporates a layer of high-viscosity lubricant instead of ball bearings in the hard drive spindle motor. FDB designs provide increased non-operational shock resistance, speed control, and improved acoustics.

**Formatted Capacity** — The actual capacity available to store data in a mass storage device. The formatted capacity is the gross capacity minus the capacity taken up by the overhead data required for formatting the media.

**Hot Plugging** — The ability to swap out a failed hard drive without having to power down the system or reboot.

**IntelliSeek** — The technology that proactively calculates an optimum seek speed to eliminate hasty movement of the actuator that produces noise and requires power.

**Latency** — The period of time that the read/write heads wait for the disk to rotate the data to an accessible position. For a disk rotating at 10,000 RPM, the average latency is 3 milliseconds.

**Logical Block Address** — An alternative addressing methodology of identifying a given location on a SATA drive that permits disk sizes greater than 528 MB.

**MicroFemto Slider** — These drives incorporate the next generation femto slider form factor in which the read/ write head is mounted on the small, lightweight microfemto slider that allows the head to move more quickly from track to track on the disk.

**Native Command Queuing (NCQ)** — NCQ allows the drive to re-order read commands, thereby increasing random read IOPs. NCQ is a true Enterprise feature for environments such as database, Web servers, and e-mail servers.

**Pre-emptive Wear Leveling (PWL)** —The feature that provides a solution for protecting the recording media against mechanical wear.

**PRML (Partial Response Maximum Likelihood)** — A read channel using sampled data, active equalization and Viterbi detection to accurately retrieve the user data off the disk.

**RoHS (Restriction of Hazardous Substances)** — Western Digital hard drive products manufactured and sold worldwide after June 8, 2011, meet or exceed Restriction of Hazardous Substances (RoHS) compliance requirements as mandated by the RoHS Directive 2011/65/EU. RoHS aims to protect human health and the environment by restricting the use of certain hazardous substances in new equipment, and consists of restrictions on lead, mercury, cadmium, and other substances.

**Rotary Acceleration Feed Forward (RAFF)** — These drives employ RAFF technology to maintain hard drive performance in high vibration environments through adaptive compensation of the servo system.

**Rotational Latency** — The amount of delay in obtaining information from a disk drive that can be attributed to the rotation of the disk. For a disk rotating at 10,000 RPM, the average latency is 3 milliseconds.

**RPM (Revolutions per Minute)** — Rotational speed of the media (disk), also known as the spindle speed.

**Seek Time** — The time it takes for the read/write head to move to a specific block of data on the hard drive. The average seek time is computed by dividing the time it takes to complete a large number of random seeks by the number of seeks performed.

**Sector** — A 512-byte packet of data.

**Self-Monitoring, Analysis, and Reporting Technology (S.M.A.R.T.)** — A technology to assist the user in preventing possible system down time due to hard drive failure.

**Serial ATA (SATA)** — SATA is the next generation bus interface for hard drives. It is designed to replace Parallel ATA, and has many advantages including increased transfer rate, improved signal integrity, enhanced data protection, and hot plugging.

**S.M.A.R.T. Command Transport (SCT)** — The SCT Command Transport feature set provides a method for a host to send commands and data to a device and for a device to send data and status to a host using log pages.

**Staggered Spinup** — SATA feature that allows the system to control whether the drive will spin up immediately or wait until the interface is fully ready.

**Thermal Asperity** — A thermal asperity is a baseline shift in the read back signal due to heating of the magneto resistive stripe on the head as a result of physical contact with the disk or a particle.

**Time-Limited Error Recovery (TLER)** — TLER prevents hard drive error recovery fallout by limiting the time the drive spends in error recovery, providing increased performance, improved availability, and lower total cost of ownership in RAID arrays.

**Unrecoverable Error** — A read error that cannot be overcome by an ECC scheme or by rereading the data when host retries are enabled.

**World Wide Name (WWN)** — The World Wide Name (WWN) defined in ATA/ATAPI-7 is a modification of the IEEE extended unique identifier 64 bit standard (EUI-64) and is comprised of three major components: naming authority, organizationally unique identifier (OUI) and serial number..

**Write Cache** — A feature in Cache Flow that posts “command complete” prior to completing the actual write.

**Western Digital.**

Hard Disk Drive Technical Reference Manual