

Version 1.0

Published November 2020

Copyright©2020 ASRock INC. All rights reserved.

## Copyright Notice:

No part of this documentation may be reproduced, transcribed, transmitted, or translated in any language, in any form or by any means, except duplication of documentation by the purchaser for backup purpose, without written consent of ASRock Inc.

Products and corporate names appearing in this documentation may or may not be registered trademarks or copyrights of their respective companies, and are used only for identification or explanation and to the owners' benefit, without intent to infringe.

## Disclaimer:

Specifications and information contained in this documentation are furnished for informational use only and subject to change without notice, and should not be construed as a commitment by ASRock. ASRock assumes no responsibility for any errors or omissions that may appear in this documentation.

With respect to the contents of this documentation, ASRock does not provide warranty of any kind, either expressed or implied, including but not limited to the implied warranties or conditions of merchantability or fitness for a particular purpose.

In no event shall ASRock, its directors, officers, employees, or agents be liable for any indirect, special, incidental, or consequential damages (including damages for loss of profits, loss of business, loss of data, interruption of business and the like), even if ASRock has been advised of the possibility of such damages arising from any defect or error in the documentation or product.



This device complies with Part 15 of the FCC Rules. Operation is subject to the following two conditions:

- (1) this device may not cause harmful interference, and
- (2) this device must accept any interference received, including interference that may cause undesired operation.

## CALIFORNIA, USA ONLY

The Lithium battery adopted on this motherboard contains Perchlorate, a toxic substance controlled in Perchlorate Best Management Practices (BMP) regulations passed by the California Legislature. When you discard the Lithium battery in California, USA, please follow the related regulations in advance.

“Perchlorate Material-special handling may apply, see [www.dtsc.ca.gov/hazardouswaste/perchlorate](http://www.dtsc.ca.gov/hazardouswaste/perchlorate)”

ASRock Website: <http://www.asrock.com>

---

## AUSTRALIA ONLY

Our goods come with guarantees that cannot be excluded under the Australian Consumer Law. You are entitled to a replacement or refund for a major failure and compensation for any other reasonably foreseeable loss or damage caused by our goods. You are also entitled to have the goods repaired or replaced if the goods fail to be of acceptable quality and the failure does not amount to a major failure. If you require assistance please call ASRock Tel : +886-2-28965588 ext.123 (Standard International call charges apply)

The terms HDMI® and HDMI High-Definition Multimedia Interface, and the HDMI logo are trademarks or registered trademarks of HDMI Licensing LLC in the United States and other countries.



# Motherboard Layout

## H410M-HDV R2.0:

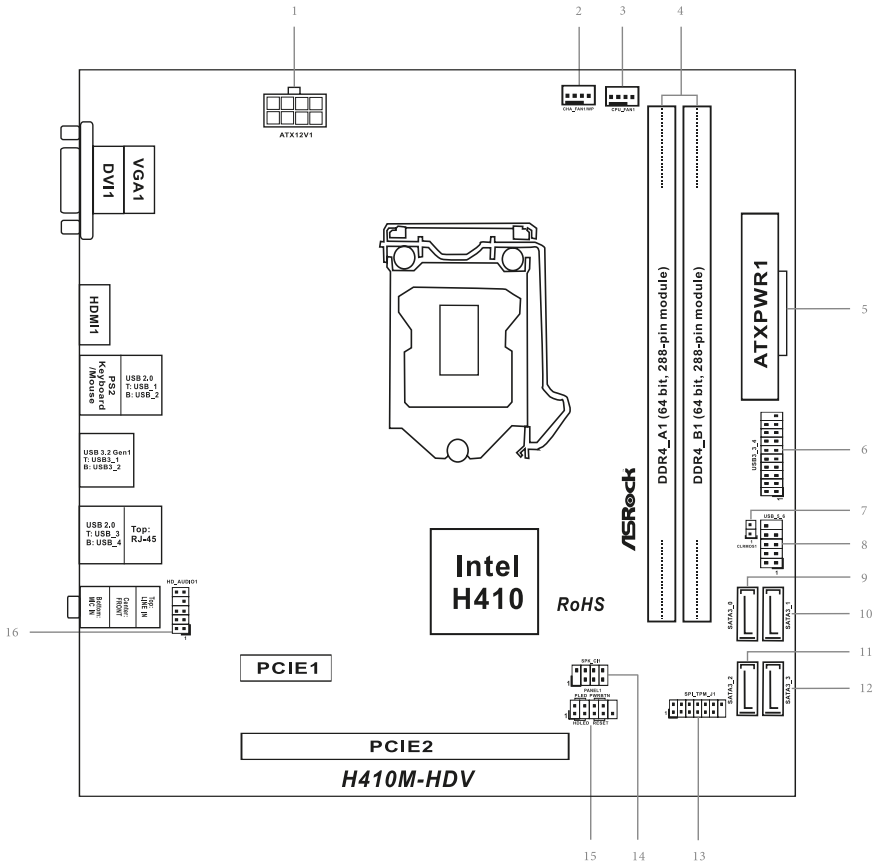

# H410M-HVS R2.0:

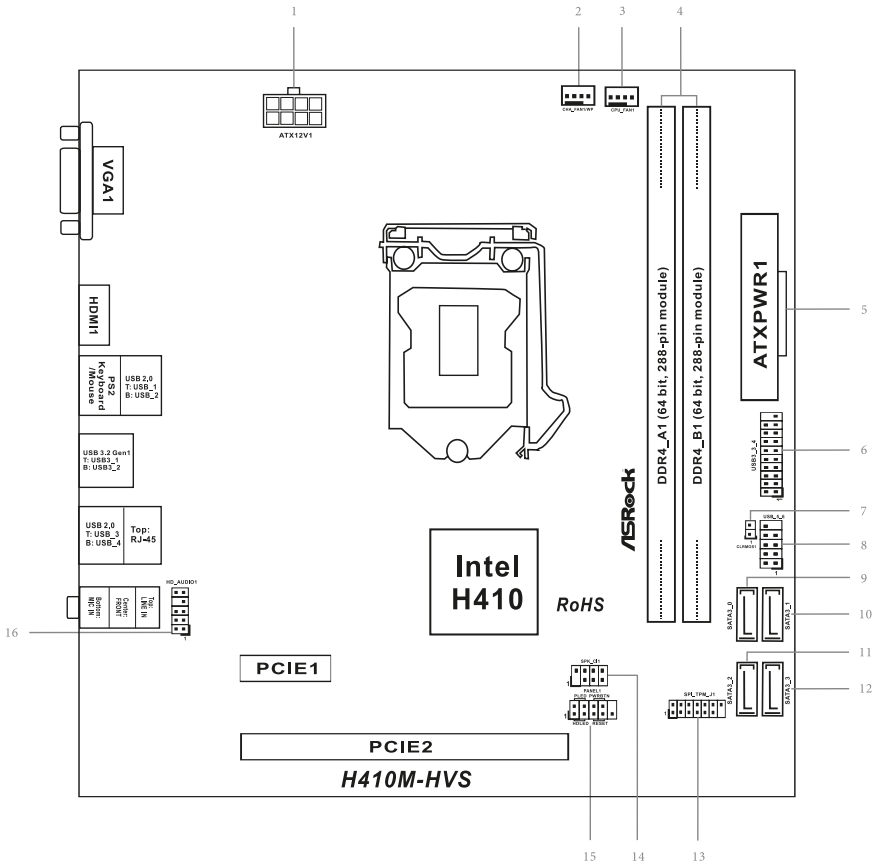

No.	Description
1	ATX 12V Power Connector (ATX12V1)
2	Chassis/Water Pump Fan Connector (CHA_FAN1/WP)
3	CPU Fan Connector (CPU_FAN1)
4	2 x 288-pin DDR4 DIMM Slots (DDR4_A1, DDR4_B1)
5	ATX Power Connector (ATXPWR1)
6	USB 3.2 Gen1 Header (USB3_3_4)
7	Clear CMOS Jumper (CLRMOS1)
8	USB 2.0 Header (USB_5_6)
9	SATA3 Connector (SATA3_0)
10	SATA3 Connector (SATA3_1)
11	SATA3 Connector (SATA3_2)
12	SATA3 Connector (SATA3_3)
13	SPI TPM Header (SPI_TPM_J1)
14	Chassis Intrusion and Speaker Header (SPK_C11)
15	System Panel Header (PANEL1)
16	Front Panel Audio Header (HD_AUDIO1)

## I/O Panel

### H410M-HDV R2.0:

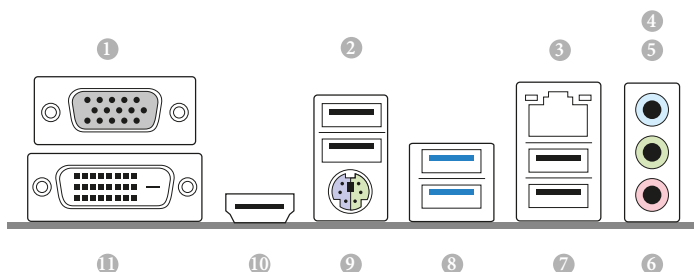

No.	Description	No.	Description
1	D-Sub Port	7	USB 2.0 Ports (USB_34)
2	USB 2.0 Ports (USB_12)	8	USB 3.2 Gen1 Ports (USB3_12)
3	LAN RJ-45 Port*	9	PS/2 Mouse/Keyboard Port
4	Line In (Light Blue)**	10	HDMI Port
5	Front Speaker (Lime)**	11	DVI-D Port
6	Microphone (Pink)**		

### H410M-HVS R2.0:

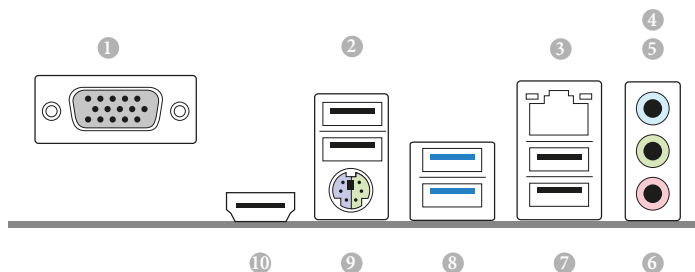

No.	Description	No.	Description
1	D-Sub Port	6	Microphone (Pink)**
2	USB 2.0 Ports (USB_12)	7	USB 2.0 Ports (USB_34)
3	LAN RJ-45 Port*	8	USB 3.2 Gen1 Ports (USB3_12)
4	Line In (Light Blue)**	9	PS/2 Mouse/Keyboard Port
5	Front Speaker (Lime)**	10	HDMI Port

\* There are two LEDs on each LAN port. Please refer to the table below for the LAN port LED indications.

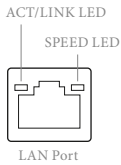

Activity / Link LED		Speed LED	
Status	Description	Status	Description
Off	No Link	Off	10Mbps connection
Blinking	Data Activity	Orange	100Mbps connection
On	Link	Green	1Gbps connection

\*\* *Function of the Audio Ports in 7.1-channel Configuration:*

Port	Function
Light Blue (Rear panel)	Rear Speaker Out
Lime (Rear panel)	Front Speaker Out
Pink (Rear panel)	Central /Subwoofer Speaker Out
Lime (Front panel)	Side Speaker Out

# Chapter 1 Introduction

Thank you for purchasing ASRock H410M-HDV R2.0 / H410M-HVS R2.0 motherboard, a reliable motherboard produced under ASRock's consistently stringent quality control. It delivers excellent performance with robust design conforming to ASRock's commitment to quality and endurance.



*Because the motherboard specifications and the BIOS software might be updated, the content of this documentation will be subject to change without notice. In case any modifications of this documentation occur, the updated version will be available on ASRock's website without further notice. If you require technical support related to this motherboard, please visit our website for specific information about the model you are using. You may find the latest VGA cards and CPU support list on ASRock's website as well. ASRock website <http://www.asrock.com>.*

## 1.1 Package Contents

- ASRock H410M-HDV R2.0 / H410M-HVS R2.0 Motherboard (Micro ATX Form Factor)
- ASRock H410M-HDV R2.0 / H410M-HVS R2.0 Quick Installation Guide
- ASRock H410M-HDV R2.0 / H410M-HVS R2.0 Support CD
- 2 x Serial ATA (SATA) Data Cables (Optional)
- 1 x I/O Panel Shield



## 1.2 Specifications

- Platform**
- Micro ATX Form Factor
  - Solid Capacitor design

- CPU**
- Supports 10<sup>th</sup> Gen Intel® Core™ Processors (Socket 1200)
  - Digi Power design
  - 5 Power Phase design
  - Supports Intel® Turbo Boost Max 3.0 Technology

- Chipset**
- Intel® H410

- Memory**
- Dual Channel DDR4 Memory Technology
  - 2 x DDR4 DIMM Slots
  - Supports DDR4 2933/2800/2666/2400/2133 non-ECC, un-buffered memory
- \* Please refer to Memory Support List on ASRock's website for more information. (<http://www.asrock.com/>)
- \* Core™ (i9/i7) support DDR4 up to 2933; Core™ (i5/i3), Pentium® and Celeron® support DDR4 up to 2666.
- Supports ECC UDIMM memory modules (operate in non-ECC mode)
  - Max. capacity of system memory: 64GB
  - Supports Intel® Extreme Memory Profile (XMP) 2.0
  - 15μ Gold Contact in DIMM Slots

- Expansion Slot**
- 1 x PCI Express 3.0 x16 Slot
- \* Supports NVMe SSD as boot disks
- 1 x PCI Express 3.0 x1 Slot

- Graphics**
- Intel® UHD Graphics Built-in Visuals and the VGA outputs can be supported only with processors which are GPU integrated.
  - Hardware Accelerated Codecs: AVC/H.264, HEVC/H.265 8bit, HEVC/H.265 10bit, VP8, VP9 8bit, VP9 10bit, MPEG 2, MJPEG, VC-1
- \* VP9 10bit and VC-1 are for decode only.
- \* VP8 and VP9 encode are not supported by Windows OS.

- Graphics, Media & Compute: Microsoft DirectX 12, OpenGL 4.5, Intel® Built In Visuals, Intel® Quick Sync Video, Hybrid / Switchable Graphics, OpenCL 2.1
- Display & Content Security: Rec. 2020 (Wide Color Gamut), Microsoft PlayReady 3.0, Intel® SGX Content Protection, UHD/HDR Blu-ray Disc

#### **H410M-HDV R2.0:**

- Three graphics output options: D-Sub, DVI-D and HDMI
- \* Supports up to 2 displays simultaneously
- Supports HDMI 1.4 with max. resolution up to 4K x 2K (4096x2160) @ 30Hz
- Supports DVI-D with max. resolution up to 1920x1200 @ 60Hz
- Supports D-Sub with max. resolution up to 1920x1200 @ 60Hz
- Supports Auto Lip Sync, Deep Color (12bpc), xvYCC and HBR (High Bit Rate Audio) with HDMI 1.4 Port (Compliant HDMI monitor is required)
- Supports HDCP 2.3 with DVI-D and HDMI 1.4 Ports
- Supports 4K Ultra HD (UHD) playback with HDMI 1.4 Port

#### **H410M-HVS R2.0:**

- Dual graphics output: support HDMI and D-Sub ports by independent display controllers
- Supports HDMI 1.4 with max. resolution up to 4K x 2K (4096x2160) @ 30Hz
- Supports D-Sub with max. resolution up to 1920x1200 @ 60Hz
- Supports Auto Lip Sync, Deep Color (12bpc), xvYCC and HBR (High Bit Rate Audio) with HDMI 1.4 Port (Compliant HDMI monitor is required)
- Supports HDCP 2.3 with HDMI 1.4 Port
- Supports 4K Ultra HD (UHD) playback with HDMI 1.4 Port

#### **Audio**

- 7.1 CH HD Audio (Realtek ALC887/897 Audio Codec)
- Supports Surge Protection

#### **LAN**

- Gigabit LAN 10/100/1000 Mb/s
- Giga PHY Intel® I219V
- Supports Wake-On-LAN

- Supports Lightning/ESD Protection
- Supports Energy Efficient Ethernet 802.3az
- Supports PXE

#### **Rear Panel I/O**

- 1 x PS/2 Mouse/Keyboard Port
- 4 x USB 2.0 Ports (Supports ESD Protection)
- 2 x USB 3.2 Gen1 Ports (Supports ESD Protection)
- 1 x RJ-45 LAN Port with LED (ACT/LINK LED and SPEED LED)
- HD Audio Jacks: Line in / Front Speaker / Microphone

#### **H410M-HDV R2.0:**

- 1 x D-Sub Port
- 1 x DVI-D Port
- 1 x HDMI Port

#### **H410M-HVS R2.0:**

- 1 x D-Sub Port
- 1 x HDMI Port

#### **Storage**

- 4 x SATA3 6.0 Gb/s Connectors, support NCQ, AHCI and Hot Plug

#### **Connector**

- 1 x SPI TPM Header
- 1 x Chassis Intrusion and Speaker Header
- 1 x CPU Fan Connector (4-pin)
- \* The CPU Fan Connector supports the CPU fan of maximum 1A (12W) fan power.
- 1 x Chassis/Water Pump Fan Connector (4-pin) (Smart Fan Speed Control)
- \* The Chassis/Water Pump Fan supports the water cooler fan of maximum 2A (24W) fan power.
- \* CHA\_FAN1/WP can auto detect if 3-pin or 4-pin fan is in use.
- 1 x 24 pin ATX Power Connector
- 1 x 8 pin 12V Power Connector
- 1 x Front Panel Audio Connector
- 1 x USB 2.0 Header (Supports 2 USB 2.0 ports) (Supports ESD Protection)
- 1 x USB 3.2 Gen1 Header (Supports 2 USB 3.2 Gen1 ports) (Supports ESD Protection)

**BIOS  
Feature**

- AMI UEFI Legal BIOS with multilingual GUI support
- ACPI 6.0 Compliant wake up events
- SMBIOS 2.7 Support
- CPU Core/Cache, GT, DRAM, PCH +1.0V, VCCST Voltage Multi-adjustment

**Hardware  
Monitor**

- Temperature Sensing: CPU, Chassis/Water Pump Fans
- Fan Tachometer: CPU, Chassis/Water Pump Fans
- Quiet Fan (Auto adjust chassis fan speed by CPU temperature): CPU, Chassis/Water Pump Fans
- Fan Multi-Speed Control: CPU, Chassis/Water Pump Fans
- CASE OPEN detection
- Voltage monitoring: +12V, +5V, +3.3V, CPU Vcore, PCH +1.0V

**OS**

- Microsoft® Windows® 10 64-bit

**Certifica-  
tions**

- FCC, CE
- ErP/EuP ready (ErP/EuP ready power supply is required)

\* For detailed product information, please visit our website: <http://www.asrock.com>



*Please realize that there is a certain risk involved with overclocking, including adjusting the setting in the BIOS, applying Untied Overclocking Technology, or using third-party overclocking tools. Overclocking may affect your system's stability, or even cause damage to the components and devices of your system. It should be done at your own risk and expense. We are not responsible for possible damage caused by overclocking.*

## Chapter 2 Installation

This is a Micro ATX form factor motherboard. Before you install the motherboard, study the configuration of your chassis to ensure that the motherboard fits into it.

### Pre-installation Precautions

Take note of the following precautions before you install motherboard components or change any motherboard settings.

- Make sure to unplug the power cord before installing or removing the motherboard components. Failure to do so may cause physical injuries and damages to motherboard components.
- In order to avoid damage from static electricity to the motherboard's components, NEVER place your motherboard directly on a carpet. Also remember to use a grounded wrist strap or touch a safety grounded object before you handle the components.
- Hold components by the edges and do not touch the ICs.
- Whenever you uninstall any components, place them on a grounded anti-static pad or in the bag that comes with the components.
- When placing screws to secure the motherboard to the chassis, please do not over-tighten the screws! Doing so may damage the motherboard.

## 2.1 Installing the CPU



1. Before you insert the 1200-Pin CPU into the socket, please check if the **PnP cap** is on the socket, if the CPU surface is unclean, or if there are any **bent pins** in the socket. Do not force to insert the CPU into the socket if above situation is found. Otherwise, the CPU will be seriously damaged.
2. Unplug all power cables before installing the CPU.

1

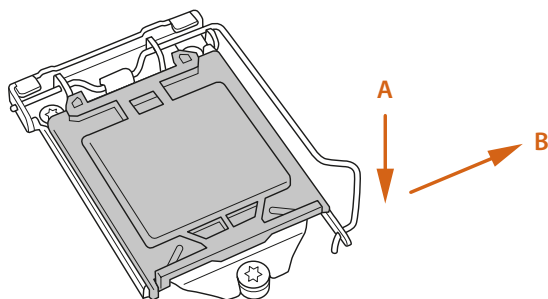

2

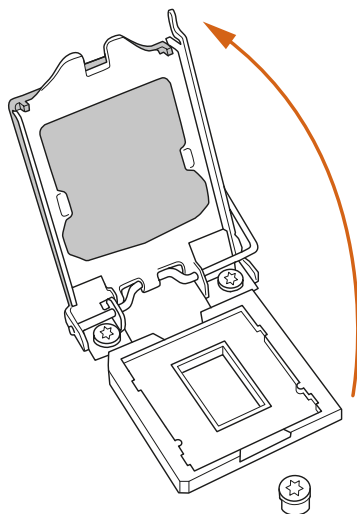

3

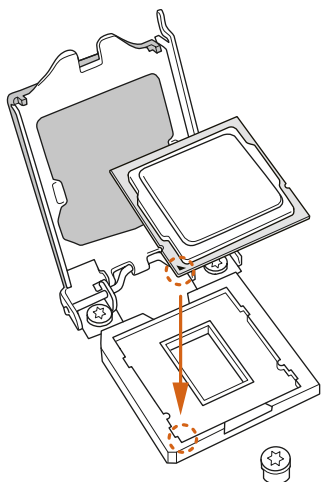

4

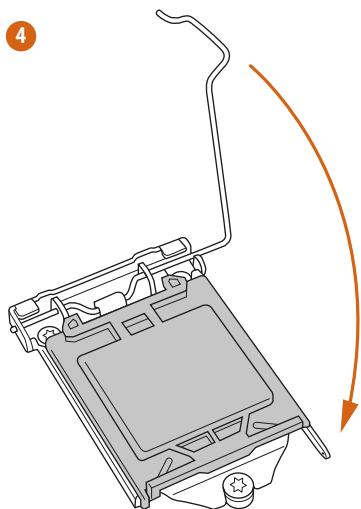

5

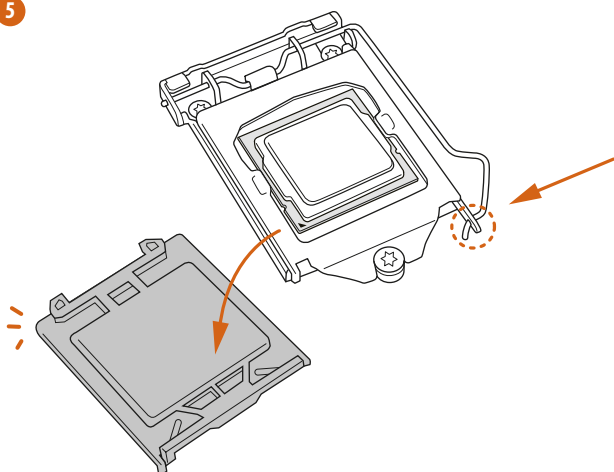

*Please save and replace the cover if the processor is removed. The cover must be placed if you wish to return the motherboard for after service.*

## 2.2 Installing the CPU Fan and Heatsink

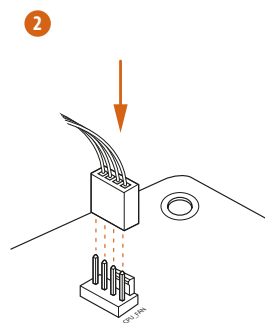
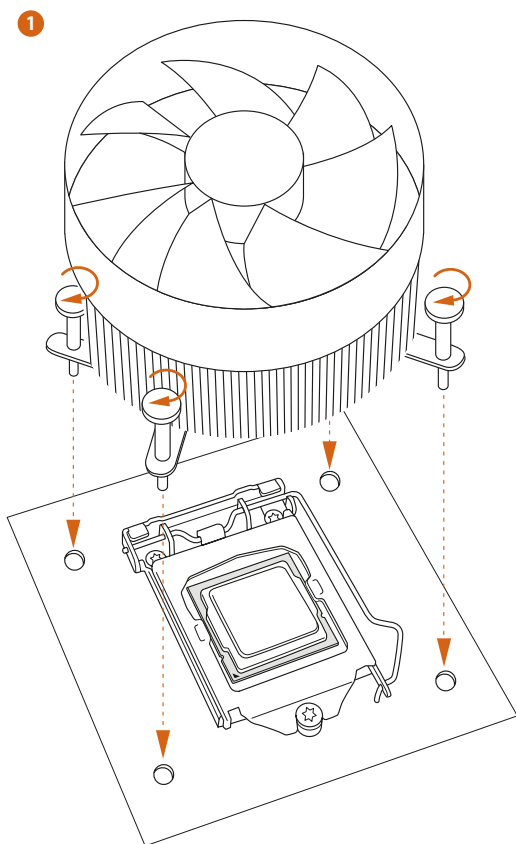
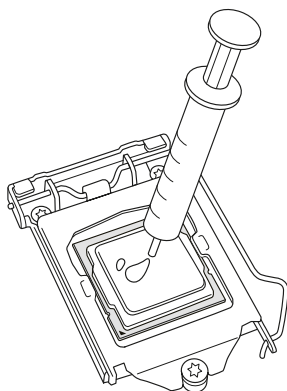



## 2.3 Installing Memory Modules (DIMM)

This motherboard provides two 288-pin DDR4 (Double Data Rate 4) DIMM slots, and supports Dual Channel Memory Technology.



1. For dual channel configuration, you always need to install identical (the same brand, speed, size and chip-type) DDR4 DIMM pairs.
2. It is unable to activate Dual Channel Memory Technology with only one memory module installed.
3. It is not allowed to install a DDR, DDR2 or DDR3 memory module into a DDR4 slot; otherwise, this motherboard and DIMM may be damaged.



*The DIMM only fits in one correct orientation. It will cause permanent damage to the motherboard and the DIMM if you force the DIMM into the slot at incorrect orientation.*

1

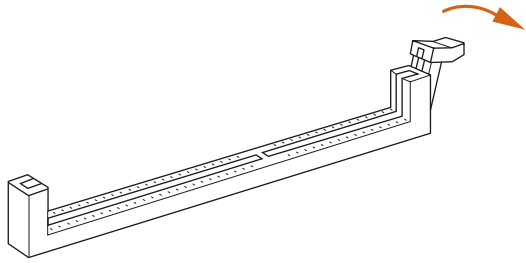

2

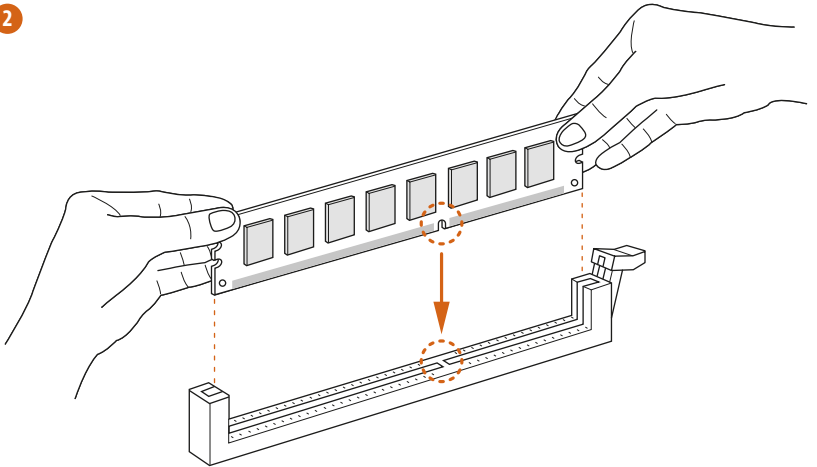

3

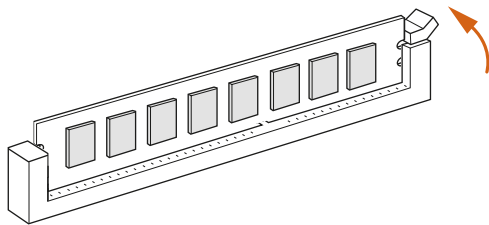

## 2.4 Expansion Slots (PCI Express Slots)

There are 2 PCI Express slots on the motherboard.



*Before installing an expansion card, please make sure that the power supply is switched off or the power cord is unplugged. Please read the documentation of the expansion card and make necessary hardware settings for the card before you start the installation.*

### **PCIe slots:**

PCIE1 (PCIe 3.0 x1 slot) is used for PCI Express x1 lane width cards.

PCIE2 (PCIe 3.0 x16 slot) is used for PCI Express x16 lane width graphics cards.

## 2.5 Jumpers Setup

The illustration shows how jumpers are setup. When the jumper cap is placed on the pins, the jumper is “Short”. If no jumper cap is placed on the pins, the jumper is “Open”.

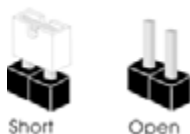

Clear CMOS Jumper  
(CLRMOSt)  
(see p.1, 2, No. 7)



Short: Clear CMOS  
Open: Default

CLRMOSt allows you to clear the data in CMOS. The data in CMOS includes system setup information such as system password, date, time, and system setup parameters. To clear and reset the system parameters to default setup, please turn off the computer and unplug the power cord, then use a jumper cap to short the pins on CLRMOSt for 3 seconds. Please remember to remove the jumper cap after clearing the CMOS. If you need to clear the CMOS when you just finish updating the BIOS, you must boot up the system first, and then shut it down before you do the clear-CMOS action.



*If you clear the CMOS, the case open may be detected. Please adjust the BIOS option “Clear Status” to clear the record of previous chassis intrusion status.*

## 2.6 Onboard Headers and Connectors



Onboard headers and connectors are NOT jumpers. Do NOT place jumper caps over these headers and connectors. Placing jumper caps over the headers and connectors will cause permanent damage to the motherboard.

System Panel Header  
(9-pin PANEL1)  
(see p.1, 2, No. 15)

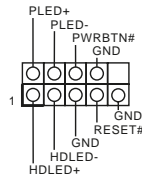

Connect the power button, reset button and system status indicator on the chassis to this header according to the pin assignments below. Note the positive and negative pins before connecting the cables.



**PWRBTN (Power Button):**

Connect to the power button on the chassis front panel. You may configure the way to turn off your system using the power button.

**RESET (Reset Button):**

Connect to the reset button on the chassis front panel. Press the reset button to restart the computer if the computer freezes and fails to perform a normal restart.

**PLED (System Power LED):**

Connect to the power status indicator on the chassis front panel. The LED is on when the system is operating. The LED keeps blinking when the system is in S1/S3 sleep state. The LED is off when the system is in S4 sleep state or powered off (S5).

**HDLED (Hard Drive Activity LED):**

Connect to the hard drive activity LED on the chassis front panel. The LED is on when the hard drive is reading or writing data.

The front panel design may differ by chassis. A front panel module mainly consists of power button, reset button, power LED, hard drive activity LED, speaker and etc. When connecting your chassis front panel module to this header, make sure the wire assignments and the pin assignments are matched correctly.

Chassis Intrusion and  
Speaker Header  
(7-pin SPK\_CI1)  
(see p.1, 2, No. 14)

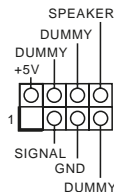

Please connect the chassis intrusion and the chassis speaker to this header.

### Serial ATA3 Connectors

(SATA3\_0:

see p.1, 2, No. 9)

(SATA3\_1:

see p.1, 2, No. 10)

(SATA3\_2:

see p.1, 2, No. 11)

(SATA3\_3:

see p.1, 2, No. 12)



These four SATA3 connectors support SATA data cables for internal storage devices with up to 6.0 Gb/s data transfer rate.

### USB 2.0 Header

(9-pin USB\_5\_6)

(see p.1, 2, No. 8)

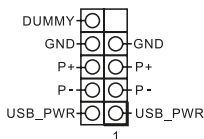

There is one header on this motherboard. This USB 2.0 header can support two ports.

### USB 3.2 Gen1 Header

(19-pin USB3\_3\_4)

(see p.1, 2, No. 6)

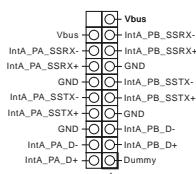

There is one header on this motherboard. This USB 3.2 Gen1 header can support two ports.

### Front Panel Audio Header

(9-pin HD\_AUDIO1)

(see p.1, 2, No. 16)

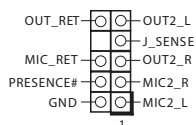

This header is for connecting audio devices to the front audio panel.



1. High Definition Audio supports Jack Sensing, but the panel wire on the chassis must support HDA to function correctly. Please follow the instructions in our manual and chassis manual to install your system.
2. If you use an AC'97 audio panel, please install it to the front panel audio header by the steps below:
  - A. Connect Mic\_IN (MIC) to MIC2\_L.
  - B. Connect Audio\_R (RIN) to OUT2\_R and Audio\_L (LIN) to OUT2\_L.
  - C. Connect Ground (GND) to Ground (GND).
  - D. MIC\_RET and OUT\_RET are for the HD audio panel only. You don't need to connect them for the AC'97 audio panel.
  - E. To activate the front mic, go to the "FrontMic" Tab in the Realtek Control panel and adjust "Recording Volume".

Chassis/Water Pump Fan  
Connector  
(4-pin CHA\_FAN1/WP)  
(see p.1, 2, No. 2)

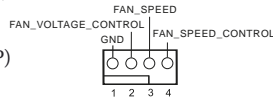

This motherboard provides one 4-Pin water cooling chassis fan connector. If you plan to connect a 3-Pin chassis water cooler fan, please connect it to Pin 1-3.

CPU Fan Connector  
(4-pin CPU\_FAN1)  
(see p.1, 2, No. 3)

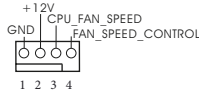

This motherboard provides a 4-Pin CPU fan (Quiet Fan) connector. If you plan to connect a 3-Pin CPU fan, please connect it to Pin 1-3.

ATX Power Connector  
(24-pin ATXPWR1)  
(see p.1, 2, No. 5)

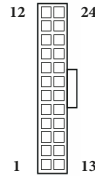

This motherboard provides a 24-pin ATX power connector. To use a 20-pin ATX power supply, please plug it along Pin 1 and Pin 13.

ATX 12V Power  
Connector  
(8-pin ATX12V1)  
(see p.1, 2, No. 1)

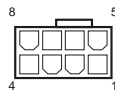

This motherboard provides a 8-pin ATX 12V power connector. To use a 4-pin ATX power supply, please plug it along Pin 1 and Pin 5.

**\*Warning: Please make sure that the power cable connected is for the CPU and not the graphics card. Do not plug the PCIe power cable to this connector.**

SPI TPM Header  
(13-pin SPI\_TPM\_J1)  
(see p.1, 2, No. 13)

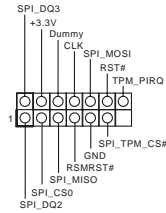

This connector supports SPI Trusted Platform Module (TPM) system, which can securely store keys, digital certificates, passwords, and data. A TPM system also helps enhance network security, protects digital identities, and ensures platform integrity.



## Technische Daten

- Plattform**
- Micro-ATX-Formfaktor
  - Feststoffkondensator-Design

- Prozessor**
- Unterstützt Intel® Core™-Prozessoren (Sockel 1200) der 10<sup>ten</sup> Generation
  - Digi Power design
  - 5-Leistungsphasendesign
  - Unterstützt Intel® Turbo Boost MAX 3.0-Technologie

- Chipsatz**
- Intel® H410

- Speicher**
- Dualkanal-DDR4-Speichertechnologie
  - 2 x DDR4-DIMM-Steckplätze
  - Unterstützt ungepufferten DDR4 2933/2800/2666/2400/2133-Non-ECC-Speicher\*
- \* Weitere Informationen finden Sie in der Speicherkompatibilitätsliste auf der ASRock-Webseite. (<http://www.asrock.com/>)
- \* Core™ (i9/i7) Unterstützt DDR4 bis zu 2933; Core™ (i5/i3), Pentium™ und Celeron® Unterstützt DDR4 bis zu 2666.
- Unterstützt ECC-UDIMM-Speichermodule (Betrieb im non-ECC-Modus)
  - Systemspeicher, max. Kapazität: 64GB
  - Unterstützt Intel® Extreme Memory Profile (XMP) 2.0
  - 15-µ-Goldkontakt in DIMM-Steckplätze

- Erweiterungssteckplatz**
- 1 x PCI-Express 3.0-x16-Steckplatz
- \* Unterstützt NVMe-SSD als Bootplatte
- 1 x PCI-Express 3.0-x1-Steckplatz

- Grafikkarte**
- Integrierte Intel® UHD Graphics-Visualisierung und VGA-Ausgänge können nur mit Prozessoren unterstützt werden, die GPU-integriert sind.
  - Hardware-beschleunigende Codecs: AVC/H.264, HEVC/H.265 8 bit, HEVC/H.265 10 bit, VP8, VP9 8 bit, VP9 10 bit, MPEG2, MJPEG, VC-1
- \* VP9 10 Bit und VC-1 dienen nur der Dekodierung.
- \* VP8- und VP9-Enkodierung werden von Windows-Betriebssystemen nicht unterstützt.

- Grafik, Medien und Rechenleistung: Microsoft DirectX 12, OpenGL 4.5, Intel® Built In Visuals, Intel® Quick Sync Video, Hybrid- / umschaltbare Grafikkarte, OpenCL 2.1
- Display & Content Security: Rec. 2020 (breiter Farbraum), Microsoft PlayReady 3.0, Intel® SGX-Inhaltsschutz, UHD/HDR Blu-ray Disc

#### **H410M-HDV R2.0:**

- Drei Grafikkarten-Ausgangsoptionen: D-Sub, DVI-D und HDMI
- \* Unterstützt bis zu 2 Displays gleichzeitig
- Unterstützt HDMI 1.4 mit maximaler Auflösung von 4K x 2K (4096 x 2160) bei 30Hz
- Unterstützt DVI-D mit maximaler Auflösung von 1920 x 1200 bei 60 Hz
- Unterstützt D-Sub mit maximaler Auflösung von 1920 x 1200 bei 60 Hz
- Unterstützt Auto-Lippensynchronizität, hohe Farbtiefe (12 bpc), xvYCC und HBR (Audio mit hoher Bitrate) mit HDMI 1.4-Port (konformer HDMI-Monitor erforderlich)
- Unterstützt HDCP 2.3 mit DVI-D- und HDMI 1.4-Ports
- Unterstützt 4K-Ultra-HD- (UHD) Wiedergabe mit HDMI 1.4-Port

#### **H410M-HVS R2.0:**

- Dualer Grafikkartenausgang: Unterstützt HDMI- und D-Sub-Ports durch unabhängige Monitor-Controller
- Unterstützt HDMI 1.4 mit maximaler Auflösung von 4K x 2K (4096 x 2160) bei 30Hz
- Unterstützt D-Sub mit maximaler Auflösung von 1920 x 1200 bei 60 Hz
- Unterstützt Auto-Lippensynchronizität, hohe Farbtiefe (12 bpc), xvYCC und HBR (Audio mit hoher Bitrate) mit HDMI 1.4-Port (konformer HDMI-Monitor erforderlich)
- Unterstützt HDCP 2.3 mit HDMI 1.4-Port
- Unterstützt 4K-Ultra-HD- (UHD) Wiedergabe mit HDMI 1.4-Port

#### **Audio**

- 7.1-Kanal-HD-Audio (Realtek ALC887/897-Audiocodec)
- Unterstützt Überspannungsschutz

#### **LAN**

- Gigabit LAN 10/100/1000 Mb/s
- Giga PHY Intel® I219V
- Unterstützt Wake-On-LAN

- Unterstützt Schutz gegen Blitzschlag/elektrostatische Entladung
- Unterstützt energieeffizientes Ethernet 802.3az
- Unterstützt PXE

#### **Rückblende, E/A**

- 1 x PS/2-Maus-/Tastaturanschluss
- 4 x USB-2.0-Ports (unterstützt Schutz gegen elektrostatische Entladung)
- 2 x USB-3.2-Gen1-Ports (unterstützt Schutz gegen elektrostatische Entladung)
- 1 x RJ-45-LAN-Port mit LED (Aktivität/Verbindung-LED und Geschwindigkeit-LED)
- HD-Audioanschlüsse: Line-in / Vorderer Lautsprecher / Mikrofon

#### **H410M-HDV R2.0:**

- 1 x D-Sub-Port
- 1 x DVI-D-Port
- 1 x HDMI-Port

#### **H410M-HVS R2.0:**

- 1 x D-Sub-Port
- 1 x HDMI-Port

#### **Speicher**

- 4 x SATA-III-6,0-Gb/s-Anschlüsse, unterstützt NCQ, AHCI und Hot-Plugging

#### **Anschluss**

- 1 x SPI-TPM-Stiftleiste
  - 1 x Gehäuseeingriff- und Lautsprecher-Stiftleiste
  - 1 x CPU-Lüfteranschluss (4-polig)
- \* Der CPU-Lüfteranschluss unterstützt einen CPU-Lüfter mit einer maximalen Lüfterleistung von 1 A (12 W).
- 1 x Anschluss Gehäuse/Wasserpumpenlüfter (4-polig) (intelligente Lüftergeschwindigkeitssteuerung)
- \* Der Gehäuse-/Wasserpumpenlüfter unterstützt einen Wasserkühlerlüfter mit einer maximalen Lüfterleistung von 2A (24 W).
- \* CHA\_FAN1/WP können automatisch erkennen, ob ein 3- oder 4-poliger Lüfter verwendet wird.
- 1 x 24-poliger ATX-Netzanschluss
  - 1 x 8-poliger 12-V-Netzanschluss
  - 1 x Audioanschluss an Frontblende
  - 1 x USB 2.0-Stiftleiste (unterstützt zwei USB 2.0-Ports) (unterstützt Schutz gegen elektrostatische Entladung)
  - 1 x USB 3.2 Gen1-Stiftleiste (unterstützt zwei USB 3.2 Gen1-Ports) (unterstützt Schutz gegen elektrostatische Entladung)

#### **Betriebs- system**

- Microsoft® Windows® 10, 64 Bit

## Spécifications

### Plateforme

- Facteur de forme Micro ATX
- Conception à condensateurs solides

### Processeur

- Prend en charge les processeurs 10<sup>ème</sup> génération Intel® Core™ (socket 1200)
- Digi Power design
- Alimentation à 5 phases
- Prend en charge la technologie Intel® Turbo Boost MAX 3.0

### Chipset

- Intel® H410

### Mémoire

- Technologie mémoire double canal DDR4
  - 2 x fentes DIMM DDR4
  - Prend en charge les mémoires sans tampon non ECC DDR4 2933/2800/2666/2400/2133
- \* Veuillez consulter la liste de prise en charge des mémoires sur le site Web d'ASRock pour de plus amples informations.  
(<http://www.asrock.com/>)
- \* Core™ (i9/i7) prend en charge DDR4 jusqu'à 2933; Core™ (i5/i3), Pentium® et Celeron® prend en charge DDR4 jusqu'à 2666.
- Prend en charge les modules mémoire UDIMM ECC (fonctionne en mode non-ECC)
  - Capacité max. de la mémoire système : 64Go
  - Prend en charge Intel® Extreme Memory Profile (XMP) 2.0
  - Contacts dorés 15µ sur fentes DIMM

### Fente d'expansion

- 1 x fente PCI Express 3.0 x16
- \* Prend en charge les SSD NVMe comme disques de démarrage
- 1 x fente PCI Express 3.0 x1

### Graphiques

- La technologie Intel® UHD Graphics Built-in Visuals et les sorties VGA sont uniquement prises en charge par les processeurs intégrant un contrôleur graphique.
  - Codecs d'accélération matérielle : AVC/H.264, HEVC/H.265 8bit, HEVC/H.265 10bit, VP8, VP9 8bit, VP9 10bit, MPEG 2, MJPEG, VC-1
- \* VP9 10 bits et VC-1 sont uniquement destinés au décodage.
- \* L'encodage VP8 et VP9 n'est pas pris en charge par le système d'exploitation Windows.

- Graphismes, multimédia et calcul : Microsoft DirectX 12, OpenGL 4.5, Intel® Built In Visuals, Intel® Quick Sync Video, Hybrid Graphics / Basculement des graphismes, OpenCL 2.1
- Affichage et sécurité du contenu : Rec. 2020 (large gamme de couleurs), Microsoft PlayReady 3.0, protection de contenu Intel® SGX, disque Blu-ray UHD/HDR

#### **H410M-HDV R2.0:**

- Trois options de sortie graphique : D-Sub, DVI-D et HDMI
- \* Prend en charge jusqu'à 2 écrans simultanément
- Prend en charge la technologie HDMI 1.4 avec résolution maximale de 4K x 2K (4096x2160) @ 30Hz
  - Prend en charge le mode DVI-D avec une résolution maximale de 1920x1200 @ 60Hz
  - Prend en charge le mode D-Sub avec une résolution maximale de 1920x1200 @ 60Hz
  - Prend en charge les technologies Auto Lip Sync, Deep Color (12bpc), xvYCC et HBR (High Bit Rate Audio) avec port HDMI 1.4 (un écran compatible HDMI est requis)
  - Prend en charge HDCP 2.3 via ports DVI-D et HDMI 1.4
  - Prend en charge la lecture 4K Ultra HD (UHD) avec le port HDMI 1.4

#### **H410M-HVS R2.0:**

- Double sortie graphique : Prend en charge les ports D-Sub et HDMI via contrôleurs d'affichage indépendants
- Prend en charge la technologie HDMI 1.4 avec résolution maximale de 4K x 2K (4096x2160) @ 30Hz
- Prend en charge le mode D-Sub avec une résolution maximale de 1920x1200 @ 60Hz
- Prend en charge les technologies Auto Lip Sync, Deep Color (12bpc), xvYCC et HBR (High Bit Rate Audio) avec port HDMI 1.4 (un écran compatible HDMI est requis)
- Prend en charge HDCP 2.3 via port HDMI 1.4
- Prend en charge la lecture 4K Ultra HD (UHD) avec le port HDMI 1.4

#### **Audio**

- Audio 7.1 CH HD (Codec audio Realtek ALC887/897)
- Prend en charge la protection contre les surtensions

#### **Réseau**

- Gigabit LAN 10/100/1000 Mo/s
- Giga PHY Intel® I219V
- Prend en charge la fonction Wake-On-LAN

- Prend en charge la protection contre la foudre/les décharges électrostatiques
- Prend en charge la fonction d'économie d'énergie Ethernet 802.3az
- Prend en charge PXE

### Connectique du panneau arrière

- 1 x port souris/clavier PS/2
- 4 x ports USB 2.0 (Protection contre les décharges électrostatiques)
- 2 x ports USB 3.2 Gen1 (Protection contre les décharges électrostatiques)
- 1 x port RJ-45 LAN avec LED (LED ACT/LIEN et LED VITESSE)
- Connecteurs jack audio HD : Entrée ligne / haut-parleur avant / microphone

#### H410M-HDV R2.0:

- 1 x port D-Sub
- 1 x port DVI-D
- 1 x port HDMI

#### H410M-HVS R2.0:

- 1 x port D-Sub
- 1 x port HDMI

### Stockage

- 4 x connecteurs SATA3 6,0 Go/s, compatibles avec les fonctions NCQ, AHCI et « Hot Plug »

### Connecteur

- 1 x embase SPI TPM
- 1 x prise DEL d'alimentation et emplacement sur châssis
- 1 x connecteur pour ventilateur de CPU (4 broches)
- \* Le connecteur pour ventilateur de CPU prend en charge un ventilateur de CPU d'une puissance maximale de 1 A (12 W).
- 1 x connecteur pour ventilateur de châssis /pompe à eau (4 broches) (contrôle de vitesse de ventilateur intelligent)
- \* Le ventilateur de châssis /pompe à eau prend en charge un ventilateur de refroidisseur d'eau d'une puissance maximale de 2A (24 W).
- \* CHA\_FAN1/WP peuvent détecter automatiquement si un ventilateur 3 broches ou 4 broches est utilisé.
- 1 x connecteur d'alimentation ATX 24 broches
- 1 x connecteur d'alimentation 12 V 8 broches
- 1 x connecteur audio panneau frontal
- 1 x embase USB 2.0 (2 ports USB 2.0 pris en charge) (Protection contre les décharges électrostatiques)
- 1 x embase USB 3.2 Gen1 (2 ports USB 3.2 Gen1 pris en charge) (Protection contre les décharges électrostatiques)

### Système d'exploitation

- Microsoft® Windows® 10 64 bits

## Specifiche

- Piattaforma**
- Fattore di forma Micro ATX
  - Design condensatore solido

- CPU**
- Supporta processori 10<sup>th</sup> Generation Intel® Core™ (Socket 1200)
  - Digi Power design
  - Potenza a 5 fasi
  - Supporta la tecnologia Intel® Turbo Boost MAX 3.0

- Chipset**
- Intel® H410

- Memoria**
- Tecnologia memoria DDR4 Dual Channel
  - 2 x alloggi DIMM DDR4
  - Supporto di memoria DDR4 2933/2800/2666/2400/2133 non-ECC, un-buffered
- \* Per maggiori informazioni fare riferimento all'elenco dei supporti di memoria sul sito di ASRock. (<http://www.asrock.com/>)
- \* Core™ (i9/i7) supporta DDR4 fino a 2933; Core™ (i5/i3), Pentium® e Celeron® supporta DDR4 fino a 2666.
- Supporta moduli di memoria ECC UDIMM (funziona in modalità non ECC)
  - Capacità max. della memoria di sistema: 64GB
  - Supporto di XMP (Extreme Memory Profile) Intel® 2.0
  - Contatti d'oro 15µ negli alloggi DIMM

- Alloggio d'espansione**
- 1 x PCI Express 3.0 x16 slot
- \* Supporto di SSD NVMe come disco d'avvio
- 1 x alloggiamento PCI Express 3.0 x1

- Grafica**
- La videografica integrata della scheda video UHD Intel® e le uscite VGA possono essere supportate soltanto con processori con GPU integrata.
  - Codec con accelerazione hardware: AVC/H.264, HEVC/H.265 8-bit, HEVC/H.265 10-bit, VP8, VP9 8-bit, VP9 10-bit, MPEG2, MJPEG, VC-1
- \* VP9 10bit e VC-1 servono solo per la decodifica.
- \* La codifica VP8 e VP9 non è supportata dal sistema operativo Windows.

- Grafica, multimedialità e calcolo: Microsoft DirectX 12, OpenGL 4.5, Grafica integrate Intel®, Sincronizzazione video Intel® Quick, Grafica ibrida/commutabile, OpenCL 2.1
- Visualizzazione e sicurezza dei contenuti: Rec. 2020 (Ampia gamma di colori), Microsoft PlayReady 3.0, Protezione dei contenuti Intel® SGX, UHD/HDR Blu-ray Disc

#### **H410M-HDV R2.0:**

- Tre opzioni di output grafico: D-Sub, DVI-D e HDMI
- \* Supporta fino a 2 display simultaneamente
- Supporta HDMI 1.4 con risoluzione massima fino a 4K x 2K (4096 x 2160) a 30Hz
- Supporta DVI-D con una risoluzione max. fino a 1920 x 1200 a 60 Hz
- Supporta D-Sub con una risoluzione max. fino a 1920 x 1200 a 60 Hz
- Supporto delle funzioni Auto Lip Sync, Deep Color (12bpc), xvYCC e HBR (High Bit Rate Audio) con porta HDMI 1.4 (è necessario un monitor compatibile HDMI)
- Supporto di HDCP 2.3 con le porte DVI-D e HDMI 1.4
- Supporto riproduzione 4K Ultra HD (UHD) sulla porta HDMI 1.4

#### **H410M-HVS R2.0:**

- Doppia uscita grafica: Supporto di porte HDMI e D-Sub tramite controller display indipendenti
- Supporta HDMI 1.4 con risoluzione massima fino a 4K x 2K (4096 x 2160) a 30Hz
- Supporta D-Sub con una risoluzione max. fino a 1920 x 1200 a 60 Hz
- Supporto delle funzioni Auto Lip Sync, Deep Color (12bpc), xvYCC e HBR (High Bit Rate Audio) con porta HDMI 1.4 (è necessario un monitor compatibile HDMI)
- Supporta HDCP 2.3 con porta HDMI 1.4
- Supporto riproduzione 4K Ultra HD (UHD) sulla porta HDMI 1.4

#### **Audio**

- Audio HD 7.1 CH (codec audio Realtek ALC887/897)
- Supporta protezione da sovratensione

#### **LAN**

- LAN Gigabit 10/100/1000 Mb/s
- Giga PHY Intel® I219V
- Supporto WOL (Wake-On-LAN)



- Supporta protezione da fulmini/scariche elettrostatiche
- Supporto Energy Efficient Ethernet 802.3az
- Supporto PXE

#### **I/O pannello posteriore**

- 1 x porta mouse/tastiera PS/2
- 4 x porte USB 2.0 (supporto protezione da scariche elettrostatiche)
- 2 x porte USB 3.2 Gen1 (supporto protezione da scariche elettrostatiche)
- 1 x porta LAN RJ-45 con LED (ACT/LINK LED e SPEED LED)
- Connettori audio HD: Ingresso linea / altoparlante frontale / microfono

#### **H410M-HDV R2.0:**

- 1 x porta D-Sub
- 1 x porta DVI-D
- 1 x porta HDMI

#### **H410M-HVS R2.0:**

- 1 x porta D-Sub
- 1 x porta HDMI

#### **Archiviazione**

- 4 x connettori SATA3 6.0 Gb/s supportano NCQ, AHCI e Hot Plug

#### **Connettore**

- 1 x connettore SPI TPM
  - 1 x collegamento altoparlante e intrusione telaio
  - 1 x connettore ventola CPU (4-pin)
- \* Il connettore ventola CPU supporta ventole CPU con potenza massima di 1 A (12 W).
- 1 x connettore ventola chassis/ventola pompa dell'acqua (4 pin) (Controllo intelligente della velocità della ventola)
- \* La ventola Chassis/ventola pompa dell'acqua supporta ventole di sistemi di raffreddamento ad acqua di potenza massima di 2A (24W).
- \* CHA\_FAN1WP sono in grado di rilevare se è in uso una ventola a 3 pin o 4 a pin.
- 1 x connettore alimentazione ATX 24 pin
  - 1 x connettore alimentazione 12 V 8-pin
  - 1 x connettore audio pannello frontale
  - 1 x connettore USB 2.0 (supporto di 2 porte USB 2.0) (supporto protezione da scariche elettrostatiche)
  - 1 x connettore USB 3.2 Gen1 (supporto di 2 porte USB 3.2 Gen1) (supporto protezione da scariche elettrostatiche)

#### **SO**

- Microsoft® Windows® 10 64 bit

## Especificaciones

- Plataforma**
- Factor de forma Micro ATX
  - Diseño de condensador sólido

- CPU**
- Compatible con la 10ª generación de procesadores Intel® Core™ (Socket 1200)
  - Digi Power design
  - Diseño de 5 fases de alimentación
  - Admite la tecnología Intel® Turbo Boost MAX 3.0

- Conjunto de chips**
- Intel® H410

- Memoria**
- Tecnología de memoria DDR4 de doble canal
  - 2 x ranuras DIMM DDR4
  - Admite memoria DDR4 2933/2800/2666/2400/2133 no ECC, sin búfer
- \* Para obtener más información, consulte la lista de memorias compatibles en el sitio web de ASRock. (<http://www.asrock.com/>)
- \* Core™ (i9/i7) compatible con DDR4 de hasta 2933; Core™ (i5/i3), Pentium® y Celeron® compatible con DDR4 de hasta 2666.
- Admite módulos de memoria UDIMM ECC (funcionamiento en modo no ECC)
  - Capacidad máxima de memoria del sistema: 64GB
  - Admite Perfil de memoria extremo de Intel® (XMP) 2.0
  - Contacto 15µ Gold en ranuras DIMM

- Ranura de expansión**
- 1 ranura PCI Express 3.0 x16
- \* Admite unidad de estado sólido de NVMe como disco de arranque
- 1 x ranura PCI Express 3.0 x1

- Gráficos**
- Intel® UHD Graphics Built-in Visuals y las salidas de VGA son compatibles únicamente con procesadores con GPU integrado.
  - Códecs acelerados por hardware: AVC/H.264, HEVC/H.265 8 bits, HEVC/H.265 10 bits, VP8, VP9 8 bits, VP9 10 bits, MPEG2, MJPEG, VC-1
- \* VP9 10 bits y VC-1 son solo para decodificación.
- \* El sistema operativo Windows no admite la codificación VP8 y VP9.

- Gráficos, Multimedia & Compute: Microsoft DirectX 12, OpenGL 4.5, Intel® Built In Visuals, Intel® Quick Sync Video, Hybrid/Switchable Graphics, OpenCL 2.1
- Seguridad de visualización y contenido: Rec. 2020 (gama de colores amplia), Microsoft PlayReady 3.0, protección de contenido Intel® SGX, disco Blu-ray UHD/HDR

#### **H410M-HDV R2.0:**

- Tres opciones de salida de gráficos: D-Sub, DVI-D y HDMI
- \* Admite hasta 2 pantallas simultáneamente
- Compatible con HDMI 1.4 con una resolución máxima de 4K x 2K (4096x2160) a 30Hz
- Admite DVI-D con una resolución máxima de 1920x1200 a 60 Hz
- Admite D-Sub con una resolución máxima de 1920x1200 a 60 Hz
- Admite Sincronización automática entre audio y video, color profundo (12 bpc), xvYCC y HBR (audio de alta tasa de bits) con puerto HDMI 1.4 (se necesita un monitor compatible con HDMI)
- Compatible con función HDCP 2.3 con puertos DVI-D y HDMI 1.4
- Admite reproducción 4K Ultra HD (UHD) con puerto HDMI 1.4

#### **H410M-HVS R2.0:**

- Salida gráfica dual: Compatible con puertos HDMI y D-Sub mediante controladores de pantalla independientes
- Compatible con HDMI 1.4 con una resolución máxima de 4K x 2K (4096x2160) a 30Hz
- Admite D-Sub con una resolución máxima de 1920x1200 a 60 Hz
- Admite Sincronización automática entre audio y video, color profundo (12 bpc), xvYCC y HBR (audio de alta tasa de bits) con puerto HDMI 1.4 (se necesita un monitor compatible con HDMI)
- Admite HDCP 2.3 con puerto HDMI 1.4
- Admite reproducción 4K Ultra HD (UHD) con puerto HDMI 1.4

#### **Audio**

- 7.1 Audio CH HD (Código de audio Realtek ALC887/897)
- Admite protección contra sobretensiones

#### **LAN**

- Gigabit LAN 10/100/1000 Mb/s
- Giga PHY Intel® I219V
- Admite la función Reactivación de LAN
- Admite protección contra rayos y descargas electrostáticas (ESD)
- Admite Ethernet 802.3az de eficiencia energética
- Admite PXE

**E/S en panel posterior**

- 1 x puerto de ratón/teclado PS/2
- 4 x Puertos USB 2.0 (admite protección contra descargas electrostáticas)
- 2 x Puertos USB 3.2 Gen1 (admite protección contra descargas electrostáticas)
- 1 x Puerto LAN RJ-45 con LED (LED DE ACTIVIDAD/ENLACE y LED DE VELOCIDAD)
- Conector de audio HD: Entrada de línea / Altavoz frontal / Micrófono

**H410M-HDV R2.0:**

- 1 x puerto D-Sub
- 1 x puerto DVI-D
- 1 x puerto HDMI

**H410M-HVS R2.0:**

- 1 x puerto D-Sub
- 1 x puerto HDMI

**Almacenamiento**

- 4 conectores SATA3 de 6,0 Gb/s, compatibles con las funciones NCQ, AHCI y Conexión en caliente

**Conector**

- 1 x Conector SPI TPM
  - 1 x cabezal de intrusión de chasis y de altavoces
  - 1 x Conector para ventilador de la CPU (4 contactos)
- \* El conector para ventilador de la CPU admite ventilador de la CPU con una potencia de ventilador de 1 A (12 W) máxima.
- 1 x Conector (4 contactos) para el ventilador de la bomba de agua/chasis (control de velocidad de ventilador inteligente)
- \* El ventilador de la bomba de agua/Chasis admite ventilador del disipador por agua con una potencia de ventilador máxima de 2A (24 W).
- \* CHA\_FAN1/WP se pueden detectar automáticamente si se usa el ventilador de 3 o 4 contactos.
- 1 x conector de alimentación ATX de 24 contactos
  - 1 x conector de alimentación de 12V de 8 contactos
  - 1 x Conector de audio en el panel frontal
  - 1 x Base de conexiones USB 2.0 (admite 2 puertos USB 2.0). Admite protección contra descargas electrostáticas.
  - 1 x base de conexiones USB 3.2 Gen1 (admite 2 puertos USB 3.2 Gen1) (Admite protección contra descargas electrostáticas)

**SO**

- Microsoft® Windows® 10 64 bits

## Технические характеристики

<b>Платформа</b>	<ul style="list-style-type: none"> <li>• Форм-фактор Micro ATX</li> <li>• Схема на основе твердотельных конденсаторов</li> </ul>
<b>ЦП</b>	<ul style="list-style-type: none"> <li>• Поддержка процессоров 10<sup>го</sup> поколения Intel® Core™ (Socket 1200)</li> <li>• Digi Power design</li> <li>• Система питания 5</li> <li>• Поддерживается технология Intel® Turbo Boost MAX 3.0</li> </ul>
<b>Чипсет</b>	<ul style="list-style-type: none"> <li>• Intel® H410</li> </ul>
<b>Память</b>	<ul style="list-style-type: none"> <li>• Двухканальная память DDR4</li> <li>• 2 гнезда DDR4 DIMM</li> <li>• Поддерживаются модули небуферизованной памяти DDR4 2933/2800/2666/2400/2133 без ECC</li> </ul> <p>* Дополнительная информация представлена в Списке совместимой памяти (Memory Support List) на веб-сайте ASRock. (<a href="http://www.asrock.com/">http://www.asrock.com/</a>)</p> <p>* Core™ (i9/i7) поддерживают память DDR4 с частотой до 2933; Core™ (i5/i3), Pentium® и Celeron® поддерживают память DDR4 с частотой до 2666.</p> <ul style="list-style-type: none"> <li>• Поддержка модулей памяти ECC UDIMM (работа в режиме, отличном от ECC)</li> <li>• Максимальный объем ОЗУ: 64 Гб</li> <li>• Поддерживается Intel® Extreme Memory Profile (XMP) 2.0</li> <li>• Позолоченные (15 мкм) контакты слотов DIMM</li> </ul>
<b>Слоты расширения</b>	<ul style="list-style-type: none"> <li>• 1 x PCI Express 3.0 x16 гнезд</li> </ul> <p>* Поддерживаются в качестве загрузочных SSD-диски типа NVMe</p> <ul style="list-style-type: none"> <li>• 1 слот PCI Express 3.0 x1</li> </ul>
<b>Графическая подсистема</b>	<ul style="list-style-type: none"> <li>• Встроенный видеоадаптер Intel® UHD Graphics и выходы VGA поддерживаются только при использовании ЦП со встроенными графическими процессорами.</li> <li>• Кодеки с аппаратным ускорением Hardware Accelerated Codecs: AVC/H.264, HEVC/H.265 8 бит, HEVC/H.265 10 бит, VP8, VP9 8 бит, VP9 10 бит, MPEG2, MJPEG, VC-1</li> </ul> <p>* VP9 10 бит и VC-1 только для декодирования.</p> <p>* Кодирование VP8 и VP9 не поддерживается ОС Windows.</p>

- Графика, мультимедиа и вычисления: Microsoft DirectX 12, OpenGL 4.5, Встроенные визуальные элементы Intel®, Intel® Quick Sync Video, Гибридная / переключаемая графика, OpenCL 2.1
- Отображение и безопасность содержания: Rec. 2020 (широкая цветовая гамма), Microsoft PlayReady 3.0, Защита содержания Intel® SGX, Диск UHD/HDR Blu-ray

#### **H410M-HDV R2.0:**

- Три видеовыхода: D-Sub, DVI-D и HDMI
- \* Поддерживается вывод одновременно на 2 монитора
- Поддержка HDMI 1.4 с максимальным разрешением до 4К × 2К (4096x2160) при 30 Гц
- Поддерживается DVI-D с максимальным разрешением до 1920x1200 при 60 Гц
- Поддерживается D-Sub с максимальным разрешением до 1920x1200 при 60 Гц
- Поддерживаются Auto Lip Sync, Deep Color (12 бит/цвет), xvYCC и HBR (High Bit Rate Audio) через порт HDMI 1.4 (требуется соответствующий HDMI-монитор)
- Поддержка функции HDCP 2.3 через порты DVI-D и HDMI 1.4
- Поддержка вывода видео с разрешением 4K Ultra HD (UHD) на порт HDMI 1.4

#### **H410M-HVS R2.0:**

- Два графических выхода: Поддержка портов HDMI и D-Sub независимыми контроллерами дисплея
- Поддержка HDMI 1.4 с максимальным разрешением до 4К × 2К (4096x2160) при 30 Гц
- Поддерживается D-Sub с максимальным разрешением до 1920x1200 при 60 Гц
- Поддерживаются Auto Lip Sync, Deep Color (12 бит/цвет), xvYCC и HBR (High Bit Rate Audio) через порт HDMI 1.4 (требуется соответствующий HDMI-монитор)
- Поддерживается HDCP 2.3 через порт HDMI 1.4.
- Поддержка вывода видео с разрешением 4K Ultra HD (UHD) на порт HDMI 1.4

#### **Звук**

- 7.1-канальный звук высокой четкости (аудиокодек Realtek ALC887/897)
- Защита от перепадов напряжения в электрической сети

#### **LAN**

- Gigabit Ethernet 10/100/1000 Мбит/с
- Giga PHY Intel® I219V
- Поддерживается пробуждение по ЛВС

- Молниезащита и защита от электростатических разрядов
- Поддерживается Energy Efficient Ethernet 802.3az
- Поддерживается PXE

#### **Тыловые порты ввода-вывода**

- 1 порт PS/2 для мыши/клавиатуры
- 4 порта USB 2.0 (с защитой от электростатических разрядов)
- 2 портов USB 3.2 Gen1 (с защитой от электростатических разрядов)
- 1 порт ЛВС RJ-45 с индикаторами («Активность/Соединение» и «Скорость»)
- Разъемы HD Audio: линейный вход / фронтальные АС / микрофон

#### **H410M-HDV R2.0:**

- 1 порт D-Sub
- 1 порт DVI-D
- 1 порт HDMI

#### **H410M-HVS R2.0:**

- 1 порт D-Sub
- 1 порт HDMI

#### **Запоминающие устройства**

- 4 порта SATA3 6,0 Гбит/с, поддерживаются NCQ, AHCI и «горячая» замена

#### **Разъемы**

- 1 колодка SPI TPM
- 1 колодка с разъемами датчика вскрытия корпуса и динамика
- 1 разъем для вентилятора охлаждения ЦП, 4-контактный
- \* Разъем процессорного вентилятора поддерживает вентилятор с потребляемым током не более 1 А (12 Вт).
- 1 разъем для корпусного вентилятора или водяной помпы (4-контактный) (смарт-регулятор скорости вентилятора)
- \* Разъем для корпуса корпусного вентилятора или водяной помпы поддерживает вентилятор с потребляемым током не более 2 А (24 Вт).
- \* Для разъемов CHA\_FAN1/WP автоматически определяется тип подключенного вентилятора: 3- или 4-контактный.
- 1 разъем питания ATX, 24-контактный
- 1 разъем питания 12 В, 8-контактный
- 1 аудиоразъем для передней панели
- 1 колодка USB 2.0 (2 порта USB 2.0 с защитой от электростатических разрядов)
- 1 колодка USB 3.2 Gen1 (2 порта USB 3.2 Gen1) (с защитой от электростатических разрядов)

#### **Операционные системы**

- Microsoft® Windows® 10 (64-разрядная)

## Especificações

<b>Plataforma</b>	<ul style="list-style-type: none"><li>• Micro ATX Form Factor</li><li>• Design de condensador sólido</li></ul>
<b>CPU</b>	<ul style="list-style-type: none"><li>• Suporta 10ª Geração de Processadores Intel® Core™ (Soquete 1200)</li><li>• Digi Power design</li><li>• Design com 5 fases de alimentação</li><li>• Suporta a tecnologia Intel® Turbo Boost MAX 3.0</li></ul>
<b>Chipset</b>	<ul style="list-style-type: none"><li>• Intel® H410</li></ul>
<b>Memória</b>	<ul style="list-style-type: none"><li>• Tecnologia de memória DDR4 de dois canais</li><li>• 2 x Slots DIMM DDR4</li><li>• Suporta memória DDR4 2933/2800/2666/2400/2133, não ECC, sem memória intermédia</li></ul> <p>* Por favor, consulte a Lista de Suporte de Memória no site da ASRock para obter mais informação. (<a href="http://www.asrock.com/">http://www.asrock.com/</a>)</p> <p>* Core™ (i9/i7) suporta DDR4 2933 por overclocking; Core™ (i5/i3), Pentium® e Celeron® suporta DDR4 2666 por overclocking.</p> <ul style="list-style-type: none"><li>• Suporta módulos de memória ECC UDIMM (opera em modo não-ECC)</li><li>• Capacidade máxima da memória do sistema: 64GB</li><li>• Suporta Extreme Memory Profile (XMP) 2.0 da Intel®</li><li>• Contato em Ouro 15µ nos slots DIMM</li></ul>
<b>Slot de expansão</b>	<ul style="list-style-type: none"><li>• 1 x slots PCI Express 3.0 x16</li></ul> <p>* Suporta NVMe SSD nos discos de inicialização</p> <ul style="list-style-type: none"><li>• 1 x slots PCI Express 3.0 x1</li></ul>
<b>Gráficos</b>	<ul style="list-style-type: none"><li>• Os gráficos incorporados Intel® UHD e as saídas VGA só podem ser suportados com processadores com GPU integrada.</li><li>• Codecs Acelerados de Hardware: AVC/H.264, HEVC/H.265 8bit, HEVC/H.265 10bit, VP8, VP9 8bit, VP9 10bit, MPEG 2, MJPEG, VC-1</li></ul> <p>* VP9 10bit e VC-1 são apenas para decodificação.</p> <p>* Codificação VP8 e VP9 não são suportados pelo SO Windows.</p>



- Gráficos, Mídia e Computador: Microsoft DirectX 12, OpenGL 4.5, Intel® Built In Visuals, Intel® Quick Sync Video, Hybrid / Switchable Graphics, OpenCL 2.1
- Visualização e Segurança do Conteúdo: Rec. 2020 (Wide Color Gamut), Microsoft PlayReady 3.0, Proteção Conteúdo SGX Intel®, Disco Blu-ray UHD/HDR

#### **H410M-HDV R2.0:**

- Três opções de saída de gráficos: D-Sub, DVI-D e HDMI
- \* Suporta até 2 monitores simultaneamente
- Suporta HDMI 1.4 com resolução máx. até 4K x 2K (4096x2160) @ 30Hz
- Suporta DVI-D com resolução máxima de até 1920x1200 @ 60Hz
- Suporta D-Sub com resolução máxima de até 1920x1200 @ 60Hz
- Suporta Auto sincronização labial, Deep Color (12bpc), xvYCC e HBR (High Bit Rate Audio) com porta HDMI 1.4 (É necessário um monitor compatível com HDMI)
- Suporta HDCP 2.3 com Portas DVI-D e HDMI 1.4
- Suporta reprodução HD Ultra (UHD) 4K com Porta HDMI 1.4

#### **H410M-HVS R2.0:**

- Saída gráfica dupla: Suporta portas HDMI e D-Sub por controladores de vídeo independentes
- Suporta HDMI 1.4 com resolução máx. até 4K x 2K (4096x2160) @ 30Hz
- Suporta D-Sub com resolução máxima de até 1920x1200 @ 60Hz
- Suporta Auto sincronização labial, Deep Color (12bpc), xvYCC e HBR (High Bit Rate Audio) com porta HDMI 1.4 (É necessário um monitor compatível com HDMI)
- Suporta HDCP 2.3 com Porta HDMI 1.4
- Suporta reprodução HD Ultra (UHD) 4K com Porta HDMI 1.4

#### **Áudio**

- Áudio 7.1 CH HD com proteção de conteúdo (Codec de áudio Realtek ALC887/897)
- Suporta Proteção de Sobretensão

#### **LAN**

- LAN Gigabit a 10/100/1000 Mb/s
- Giga PHY Intel® I219V
- Suporta Wake-On-LAN
- Oferece Suporte à Proteção de Relâmpago/ESD
- Suporta Energy Efficient Ethernet 802.3az
- Suporta PXE

**E/S do  
painel  
posterior**

- 1 x Porta PS/2 para mouse/teclado
- 4 x Portas USB 2.0 (Suporta Proteção ESD)
- 2 x Portas USB 3.2 Gen1 (Suporta Proteção ESD)
- 1 x Porta LAN RJ-45 com LED (LED ACT/LINK e LED DE VELOCIDADE)
- Fichas de áudio HD: Entrada de Linha / Autofalante Frontal / Microfone

**H410M-HDV R2.0:**

- 1 x Porta D-Sub
- 1 x Porta DVI-D
- 1 x Porta HDMI

**H410M-HVS R2.0:**

- 1 x Porta D-Sub
- 1 x Porta HDMI

**Armazena-  
mento**

- 4 x Conectores SATA3 6,0 Gb/s, suporte NCQ, AHCI, Conector a Quente

**Conector**

- 1 x Plataforma SPI TPM
- 1 x Intrusão do Chassi e Cabeçote de Autofalante
- 1 x Conector da ventoinha da CPU (4 pinos)
- \* O Conector do Ventilador de CPU suporta o ventilador de CPU de alimentação máxima 1A do ventilador (12W).
  - 1 x Conector do ventilador do chassi/Ventilador da Bomba de Água (4 pinos) (Controle de Velocidade de Ventoinha Inteligente)
- \* O Ventilador de Chassi/Ventilador da Bomba de Água suporta o ventilador de refrigerador a água de 2A máximo (24W) potência do ventilador.
- \* CHA\_FAN1/WP podem detectar automaticamente se ventoinha de 3 pinos ou 4 pinos está em uso.
  - 1 x Conector alimentação ATX 24 pinos
  - 1 x Conector de energia 8-pinos 12V
  - 1 x Conector de áudio do painel frontal
  - 1 x Plataforma USB 2.0 (Suporta 2 portas USB 2.0) (Suporta Proteção ESD)
  - 1 x Plataforma USB 3.2 Gen1 (Suporta 2 portas USB 3.2 Gen1) (Suporta Proteção ESD)

**SO**

- Microsoft® Windows® 10 64-bit

## Specyfikacje

- Platforma**
- Współczynnik kształtu Micro ATX
  - Konstrukcja kondensatorami stałymi

- CPU**
- Obsługa 10<sup>tej</sup> Gen procesorów Intel® Core™ (Socket 1200)
  - Digi Power design
  - Sekcja zasilania 5 Power Phase Design
  - Obsługa technologii Intel® Turbo Boost MAX 3.0

- Chipset**
- Intel® H410

- Pamięć**
- Technologia pamięci Dual Channel DDR4
  - 2 x gniazda DDR4 DIMM
  - Obsługa pamięci DDR4 2933/2800/2666/2400/2133 non-ECC, pamięć niebuforowana
- \* Sprawdź listę obsługiwanej pamięci na stronie internetowej ASRock w celu uzyskania dalszych informacji. (<http://www.asrock.com/>)
- \* Core™ (i9/i7) obsługuje DDR4 do 2933; Core™ (i5/i3), Pentium® and Celeron® obsługuje DDR4 do 2666.
- Obsługa modułów pamięci ECC UDIMM (działanie w trybie non-ECC)
  - Maks. wielkość pamięci systemowej: 64GB
  - Obsługa Intel® Extreme Memory Profile (XMP) 2.0
  - 15μm połączone styki w gniazdach DIMM

- Gniazdo rozszerzenia**
- 1 x gniazdo PCI Express 3.0 x16
- \* Obsługa SSD NVMe, jako dysków rozruchowych
- 1 x gniazdo PCI Express 3.0 x1

- Grafika**
- Wbudowana grafika Intel® UHD i wyjścia VGA są obsługiwane wyłącznie z procesorami, które mają zintegrowane GPU.
  - Sprzętowo przyspieszane kodeki: AVC/H.264, HEVC/H.265 8-bit, HEVC/H.265 10-bit, VP8, VP9 8-bit, VP9 10-bit, MPEG2, MJPEG, VC-1
- \* VP9 10bit i VC-1 służą wyłącznie do dekodowania.
- \* VP8 i VP9 kodowania nie są obsługiwane przez system operacyjny Windows.

- Grafika, Media i komputery: Microsoft DirectX 12, OpenGL 4.5, Intel® Built In Visuals, Intel® Quick Sync Video, Hybrid / Switchable Graphics, OpenCL 2.1
- Bezpieczeństwo wyświetlania i treści: Rec. 2020 (Wide Color Gamut), Microsoft PlayReady 3.0, Intel® SGX Content Protection, UHD/HDR Blu-ray Disc

#### **H410M-HDV R2.0:**

- Opcje trzech wyjść graficznych: D-Sub, DVI-D i HDMI
- \* Obsługa do 2 monitorów jednocześnie
- Obsługa HDMI 1.4 z maks. rozdzielczością do 4K x 2K (4096x2160) przy 30Hz
- Obsługa DVI-D z maks. rozdzielczością do 1920x1200 przy 60Hz
- Obsługa D-Sub z maks. rozdzielczością do 1920x1200 przy 60Hz
- Obsługa Auto Lip Sync, Deep Color (12bpc), xvYCC i HBR (High Bit Rate Audio) z portami HDMI 1.4 (Wymagany monitor zgodny z HDMI)
- Obsługa HDCP 2.3 z portami DVI-D i HDMI 1.4
- Obsługa odtwarzania 4K Ultra HD (UHD) z portem HDMI 1.4

#### **H410M-HVS R2.0:**

- Podwójne wyjście graficzne: obsługa HDMI i D-Sub przez niezależne sterowniki graficzne
- Obsługa HDMI 1.4 z maks. rozdzielczością do 4K x 2K (4096x2160) przy 30Hz
- Obsługa D-Sub z maks. rozdzielczością do 1920x1200 przy 60Hz
- Obsługa Auto Lip Sync, Deep Color (12bpc), xvYCC i HBR (High Bit Rate Audio) z portami HDMI 1.4 (Wymagany monitor zgodny z HDMI)
- Obsługa HDCP 2.3 z portem HDMI 1.4
- Obsługa odtwarzania 4K Ultra HD (UHD) z portem HDMI 1.4

#### **Audio**

- Dźwięk HD 7.1 CH (kodek audio Realtek ALC887/897)
- Obsługa zabezpieczenia przed przepięciami

#### **LAN**

- Gigabit LAN 10/100/1000 Mb/s
- Giga PHY Intel® I219V
- Obsługa Wake-On-LAN

- Obsługa zabezpieczenia przed wyładowaniami atmosferycznymi/ESD
- Obsługa Energy Efficient Ethernet 802.3az
- Obsługa PXE

#### Tyłny panel

#### Wejścia/

#### Wyjścia

- 1 x port myszy/klawiatury PS/2
- 4 x porty USB 2.0 (Obsługa zabezpieczenia ESD)
- 2 x porty USB 3.2 Gen1 (Obsługa zabezpieczenia ESD)
- 1 x port LAN RJ-45 z LED (LED ACT/LINK i LED SPEED)
- Gniazda audio HD: Wejście liniowe / Głośnik przedni / Mikrofon

#### H410M-HDV R2.0:

- 1 x port D-Sub
- 1 x port DVI-D
- 1 x port HDMI

#### H410M-HVS R2.0:

- 1 x port D-Sub
- 1 x port HDMI

#### Przechowywanie

- 4 x złącza SATA3 6,0 Gb/s, obsługa NCQ, AHCI i Hot Plug

#### Złącze

- 1 x złącze główkowe SPI TPM
- 1 x złącze główkowe naruszenia obudowy i głośnika
- 1 x złącze wentylatora CPU (4-pinowe)
- \* Złącze wentylatora CPU obsługuje wentylator CPU maksymalnym prądem zasilania wentylatora 1A (12W).
- 1 x złącza wentylatora obudowy/pompy wodnej (4-pinowe) (Inteligentne sterowanie prędkością obrotową wentylatora)
- \* Złącze wentylatora obudowy/pompy wodnej obsługuje wentylator układu chłodzenia maksymalnym prądem zasilania wentylatora 2A (24W).
- \* CHA\_FAN1/WP może automatycznie wykrywać, jeśli używany jest wentylator 3-pinowy lub 4-pinowy.
- 1 x 24 pinowe złącze zasilania ATX
- 1 x 8 pinowe złącze zasilania 12 V
- 1 x złącze audio na panelu przednim
- 1 x złącza główkowe USB 2.0 (obsługuje 2 porty USB 2.0) (Obsługa zabezpieczenia ESD)
- 1 x port główkowe USB 3.2 Gen1 (obsługa 2 portów USB 3.2 Gen1) (obsługa zabezpieczenia ESD)

#### System operacyjny

- Microsoft® Windows® 10 64-bitowy

## 규격

- 플랫폼**
- Micro ATX 폼 팩터
  - 솔리드 콘텐서 구조

- CPU**
- 10 세대 Intel® Core™ 프로세서 지원 (소켓 1200)
  - Digi Power design
  - 5 개 전원 위상 구조
  - Intel® Turbo Boost MAX 3.0 기술 지원

- 칩세트**
- Intel® H410

- 메모리**
- 듀얼 채널 DDR4 메모리 기술
  - DDR4 DIMM 슬롯 2 개
  - DDR4 2933/2800/2666/2400/2133 비 ECC, 비버퍼링 메모리 지원
- \* 추가 정보를 원하시면 ASRock 웹사이트에 있는 메모리 지원 목록을 참조하십시오. (<http://www.asrock.com/>)
- \* Core™ (i9/i7) 는 최대 2933 까지 DDR4를 지원하고; Core™ (i5/i3), Pentium® 및 Celeron® 는 최대 2666 까지 DDR4 를 지원하고 .
- ECC UDIMM 메모리 모듈 (비-ECC 모드에서 작동함) 지원
  - 시스템 메모리 최대 용량 : 64GB
  - Intel® Extreme Memory Profile (XMP) 2.0 지원
  - DIMM 슬롯에 15μ Gold Contact 장착

- 확장 슬롯**
- PCI Express 3.0 x16 슬롯 1 개
- \* NVMe SSD 를 부팅 디스크로 사용 가능하도록 지원
- PCI Express 3.0 x1 슬롯 1 개

- 그래픽**
- Intel® UHD 그래픽스 빌트-인 비주얼과 VGA 출력은 GPU 통합 프로세서로만 지원할 수 있습니다 .
  - 하드웨어 가속 코덱 : AVC/H.264, HEVC/H.265 8- 비트 , HEVC/H.265 10- 비트 , VP8, VP9 8- 비트 , VP9 10- 비트 , MPEG2, MJPEG, VC-1
- \* VP9 10 비트 및 VC-1 는 디코딩 전용입니다 .
- \* VP8 및 VP9 인코딩은 Windows OS 에서 지원되지 않습니다 .

- 그래픽, 미디어 & 컴퓨팅 : Microsoft DirectX 12, OpenGL 4.5, Intel® Built In Visuals, Intel® Quick Sync Video, Hybrid / Switchable Graphics, OpenCL 2.1
- 디스플레이 & 콘텐츠 보안 : Rec. 2020 (Wide Color Gamut), Microsoft PlayReady 3.0, Intel® SGX Content Protection, UHD/HDR 블루레이 디스크

**H410M-HDV R2.0:**

- 그래픽 출력 옵션 세 개 : D-Sub, DVI-D 및 HDMI
- \* 최대 2 개의 디스플레이를 동시에 지원
- HDMI 1.4 지원 ( 최대 해상도 4K x 2K (4096x2160) @ 30Hz)
- DVI-D 지원 ( 최대 해상도 1920x1200 @ 60Hz)
- D-Sub 지원 ( 최대 해상도 1920x1200 @ 60Hz)
- Auto Lip Sync, Deep Color (12bpc), xvYCC 및 HBR (High Bit Rate Audio)(HDMI 1.4 포트 포함 ) 지원 (HDMI 호환 모니터 필요 )
- DVI-D 및 HDMI 1.4 포트를 이용한 HDCP 2.3 지원
- HDMI 1.4 포트를 이용한 4K Ultra HD(UHD) 재생 지원

**H410M-HVS R2.0:**

- 이중 그래픽 출력 : 독립적 디스플레이 컨트롤러로 HDMI 및 D-Sub 포트 지원
- HDMI 1.4 지원 ( 최대 해상도 4K x 2K (4096x2160) @ 30Hz)
- D-Sub 지원 ( 최대 해상도 1920x1200 @ 60Hz)
- Auto Lip Sync, Deep Color (12bpc), xvYCC 및 HBR (High Bit Rate Audio)(HDMI 1.4 포트 포함 ) 지원 (HDMI 호환 모니터 필요 )
- HDMI 2.3 포트를 이용한 HDCP 1.4 지원
- HDMI 1.4 포트를 이용한 4K Ultra HD(UHD) 재생 지원

**오디오**

- 7.1 CH HD 오디오 (Realtek ALC887/897 오디오 코덱 )
- 서비 보호 지원

**LAN**

- Gigabit LAN 10/100/1000 Mb/s
- Giga PHY Intel® I219V
- Wake-On-LAN 지원
- 번개 /ESD 보호 지원
- 절전형 이더넷 802.3az 지원
- PXE 지원

**후면 패널 I/O**

- PS/2 마우스 / 키보드 포트 1 개
- USB 4 포트 2 개 (ESD 보호 지원)
- USB 3.2 Gen1 포트 2 개 (ESD 보호 지원)
- LED 장착 RJ-45 LAN 포트 1 개 (ACT/LINK LED 및 SPEED LED)
- HD 오디오 잭 : 라인 입력 / 전면 스피커 / 마이크

**H410M-HDV R2.0:**

- D-Sub 포트 1 개
- DVI-D 포트 1 개
- HDMI 포트 1 개

**H410M-HVS R2.0:**

- D-Sub 포트 1 개
- HDMI 포트 1 개

**저장 장치**

- SATA3 6.0 Gb/s 커넥터 4 개 , NCQ, AHCI 및 핫 플러그 지원

**커넥터**

- SPI TPM 헤더 1 개
- 새시 침입 및 스피커 헤더 1 개
- CPU 팬 커넥터 (4 핀) 1 개
- \* CPU 팬 커넥터는 팬 전력이 최대 1A(12W) 인 CPU 팬을 지원합니다 .
- 새시 / 워터 펌프 팬 커넥터 (4 핀) 1 개 (스마트 팬 속도 제어)
- \* 새시 / 워터 펌프 팬은 팬 전력이 최대 2A(24W) 인 수냉식 쿨러 팬을 지원합니다 .
- \* 3 핀 또는 4 핀 팬이 사용 중인 경우 , CHA\_FAN1/WP 가 자동으로 감지할 수 있습니다 .
- 24 핀 ATX 전원 커넥터 1 개
- 8 핀 12V 전원 커넥터 1 개
- 전면 패널 오디오 커넥터 1 개
- USB 2.0 헤더 1 개 (USB 2.0 포트 2 개 지원) (ESD 보호 지원)
- USB 3.2 Gen1 헤더 1 개 (USB 3.2 Gen1 포트 2 개 지원) (ESD 보호 지원)

**OS**

- Microsoft® Windows® 10 64- 비트



## 仕様

- プラットフォーム**
- マイクロ ATX フォームファクター
  - 固体コンデンサ設計

- CPU**
- 第 10 世代 Intel® Core™ プロセッサに対応(ソケット 1200)
  - デジタル電源設計
  - 5 電源フェーズ設計
  - Intel® ターボブースト MAX 3.0 テクノロジーをサポート

- チップセット**
- Intel® H410

- メモリ**
- デュアルチャンネル DDR4 メモリ機能
  - 2 x DDR4 DIMM スロット
  - DDR4 2933/2800/2666/2400/2133 ノン ECC、アンバッファードメモリに対応
- \* 詳細については、ASRock ウェブサイトのメモリーサポート一覧を参照してください。(http://www.asrock.com/)
- \* Core™ (i9/i7) は最大 2933 までの DDR4 に対応します ; Core™ (i5/i3), Pentium® および Celeron® は最大 2666 までの DDR4 に対応します。
- ECC UDIMM メモリモジュールに対応(non-ECC モードで動作)
  - システムメモリの最大容量: 64GB
  - Intel® エクストリームメモリアプロファイル (XMP) 2.0 に対応
  - DIMM スロットに 15μ ゴールドコンタクトを採用

- 拡張スロット**
- 1 x PCI Express 3.0 x16 スロット
- \* 起動ディスクとして NVMe SSD に対応
- 1 x PCI Express 3.0 x1 スロット

- グラフィックス**
- Intel® UHD グラフィックス内蔵ビジュアルおよび VGA 出力は、GPU に統合されたプロセッサのみでサポートされます。
  - ハードウェア・アクセラレイテッド・コーデック: AVC/H.264、HEVC/H.265 8- ビット、HEVC/H.265 10- ビット、VP8、VP9 8- ビット、VP9 10- ビット、MPEG2、MJPEG、VC-1
- \* VP9 10 ビットおよび VC-1 は、デコード用のみです。
- \* VP8 および VP9 エンコードは、Windows OS によりサポートされません。

- グラフィック、メディアおよびコンピュータ: Microsoft DirectX 12、OpenGL 4.5、インテル® ビルトイン・ビジュアル、インテル® クイック・シンク・ビデオ、ハイブリッド / スイッチャブル・グラフィックス、OpenCL 2.1
- ディスプレイおよびコンテンツのセキュリティ: Rec. 2020 (Wide Color Gamut)、Microsoft PlayReady 3.0、インテル® SGX コンテンツ保護、UHD/HDR Blu-ray ディスク

**H410M-HDV R2.0:**

- 3つのグラフィックス出力オプション: D-Sub、DVI-D、HDMI
- \* 最大2台のディスプレイを同時に対応します
- HDMI 1.4 テクノロジーに対応、最大解像度 4K x 2K (4096x2160) @ 30Hz
- DVI-D に対応、最大解像度 1920x1200 @60Hz
- D-Sub に対応、最大解像度 1920x1200 @60Hz
- HDMI 1.4 ポートでオートリップシンク、ディープカラー (12bpc)、xvYCC、および、HBR(高ビットレートオーディオ)に対応(HDMI 対応モニターが必要です)
- DVI-D ポートと HDMI 1.4 ポートで HDCP 2.3 に対応
- HDMI 1.4 ポートで 4K Ultra HD (UHD) 再生に対応

**H410M-HVS R2.0:**

- デュアルグラフィックス出力: 独立したディスプレイコントローラーで HDMI ポートと D-Sub ポートに対応
- HDMI 1.4 テクノロジーに対応、最大解像度 4K x 2K (4096x2160) @ 30Hz
- D-Sub に対応、最大解像度 1920x1200 @60Hz
- HDMI 1.4 ポートでオートリップシンク、ディープカラー (12bpc)、xvYCC、および、HBR(高ビットレートオーディオ)に対応(HDMI 対応モニターが必要です)
- HDMI 1.4 ポートで HDCP 2.3 に対応
- HDMI 1.4 ポートで 4K Ultra HD (UHD) 再生に対応

**オーディオ**

- 7.1 CH HD オーディオ (Realtek ALC887/897 Audio Codec)
- サージ保護に対応

**LAN**

- ギガビット LAN 10/100/1000 Mb/s
- ギガ PHY Intel® I219V
- Wake-On-LAN(ウェイク オン ラン)に対応
- 雷 / 静電気放電 (ESD) 保護に対応
- エネルギー効率のよいイーサネット 802.3az をサポート
- PXE をサポート

## リアパネル I/O

- 1 x PS/2 マウス / キーボードポート
- 4 x USB 2.0 ポート(静電気放電 (ESD) 保護に対応)
- 2 x USB 3.2 Gen1 ポート(静電気放電 (ESD) 保護に対応)
- LED 付き 1 x RJ-45 LAN ポート(ACT/LINK LED と SPEED LED)
- HD オーディオジャック: ラインイン / フロントスピーカー / マイク

### H410M-HDV R2.0:

- 1 x D-Sub ポート
- 1 x DVI-D ポート
- 1 x HDMI ポート

### H410M-HVS R2.0:

- 1 x D-Sub ポート
- 1 x HDMI ポート

## ストレージ

- 4 x SATA3 6.0 Gb/s コネクタ, NCQ, AHCI, および、ホットプラグ機能に対応

## コネクタ

- 1 x SPI TPM ヘッダー
  - 1 x シャーシイントルージョンとスピーカーヘッダー
  - 1 x CPU ファンコネクタ(4ピン)
- \* CPU ファンコネクタは最大 1A (12W) の電力の CPU ファンに対応します。
- 1 x シャーシ / ウォーターポンプファンコネクタ(4ピン)(スマートファン速度制御)
- \* シャーシ / ウォーターポンプファンは最大 2A (24W) の出力のウォータークーラーに対応します。
- \* CHA\_FAN1/WP は 3ピンまたは 4ピンファンが使用されているかどうかを自動検出できます。
- 1 x 24ピン ATX 電源コネクタ
  - 1 x 8ピン 12V 電源コネクタ
  - 1 x 前面パネルオーディオコネクタ
  - 1 x USB 2.0 ヘッダー(2つの USB 2.0 ポートに対応)(静電気放電 (ESD) 保護に対応)
  - 1 x USB 3.2 Gen1 ヘッダー(2つの USB 3.2 Gen1 ポートに対応)(静電気放電 (ESD) 保護に対応)

## OS

- Microsoft® Windows® 10 64-bit

## 规格

### 平台

- Micro ATX 规格尺寸
- 稳固的电容器设计

### CPU

- 支持第 10 代 Intel® Core™ 处理器（插座 1200）
- Digi Power design
- 5 电源相设计
- 支持 Intel® Turbo Boost MAX 3.0 技术

### 芯片集

- Intel® H410

### 内存

- 双通道 DDR4 内存技术
- 2 x DDR4 DIMM 槽
- 支持 DDR4 2933/2800/2666/2400/2133 非 ECC，非缓冲内存
- \* 请参阅华硕网站上的 Memory Support List（内存支持列表）了解详情。（<http://www.asrock.com/>）
- \* Core™ (i9/i7) 支持 DDR4 最高达 2933; Core™ (i5/i3), Pentium® 和 Celeron® 支持 DDR4 最高达 2666。
- 支持 ECC UDIMM 内存模块（非 ECC 模式操作）
- 支持系统内存最大容量：64GB
- 支持 Intel® Extreme Memory Profile (XMP) 2.0
- DIMM 插槽中 15μ 金触点

### 扩充槽

- 1 x PCI Express 3.0 x16 槽
- \* 支持 NVMe SSD 用作启动盘
- 1 x PCI Express 3.0 x1 槽

### 图形

- 只有 GPU 集成的处理器才支持 Intel® UHD Graphics 内置视效和 VGA 输出。
- 硬件加速编解码器：AVC/H.264、HEVC/H.265 8-bit、HEVC/H.265 10-bit、VP8、VP9 8-bit、VP9 10-bit、MPEG2、MJPEG、VC-1
- \* VP9 10 位和 VC-1 仅用于解码。
- \* Windows 操作系统不支持 VP8 和 VP9 编码。

- 显卡、媒体和计算：Microsoft DirectX 12、OpenGL 4.5、Intel® Built In Visuals、Intel® 高速视频同步、混合 / 可切换显卡、OpenCL 2.1
- 显示和内容安全：Rec. 2020（广色域）、Microsoft PlayReady 3.0、Intel® SGX 内容保护、UHD/HDR 蓝光光盘

#### **H410M-HDV R2.0:**

- 3 个图形输出选项：D-Sub、DVI-D 和 HDMI
- \* 同时最多支持两个 2 显示器
- 支持 HDMI 1.4，30Hz 时最大分辨率达 4K x 2K (4096x2160)
- 支持 DVI-D，60Hz 时最大分辨率达 1920x1200
- 支持 D-Sub，60Hz 时最大分辨率达 1920x1200
- 通过 HDMI 1.4 端口（需要兼容的 HDMI 显示器）支持 Auto Lip Sync、Deep Color (12bpc), xvYCC 和 HBR（高位速率音频）
- 通过 DVI-D 和 HDMI 1.4 端口支持 HDCP 2.3
- 通过 HDMI 1.4 端口支持 4K 超高清 (UHD) 播放

#### **H410M-HVS R2.0:**

- 双图形输出：通过独立显示控制器支持 HDMI 和 D-Sub 端口
- 支持 HDMI 1.4，30Hz 时最大分辨率达 4K x 2K (4096x2160)
- 支持 D-Sub，60Hz 时最大分辨率达 1920x1200
- 通过 HDMI 1.4 端口（需要兼容的 HDMI 显示器）支持 Auto Lip Sync、Deep Color (12bpc), xvYCC 和 HBR（高位速率音频）
- 通过 HDMI 1.4 端口支持 HDCP 2.3
- 通过 HDMI 1.4 端口支持 4K 超高清 (UHD) 播放

#### 音频

- 7.1 CH 高清音频（Realtek ALC887/897 音频编解码器）
- 支持电涌保护

#### LAN

- Gigabit LAN 10/100/1000 Mb/s
- Giga PHY Intel® I219V
- 支持 Wake-On-LAN（网上唤醒）
- 支持雷电 /ESD 保护
- 支持高性能以太网 802.3az
- 支持 PXE

## 后面板 I/O

- 1 x PS/2 鼠标 / 键盘端口
- 4 x USB 2.0 端口 (支持 ESD 保护)
- 2 x USB 3.2 Gen1 端口 (支持 ESD 保护)
- 1 x RJ-45 LAN 端口, 带 LED (ACT/LINK LED 和 SPEED LED)
- 高清音频插孔: 线路输入 / 前扬声器 / 麦克风

**H410M-HDV R2.0:**

- 1 x D-Sub 端口
- 1 x DVI-D 端口
- 1 x HDMI 端口

**H410M-HVS R2.0:**

- 1 x D-Sub 端口
- 1 x HDMI 端口

## 存储

- 4 x SATA3 6.0 Gb/s 接口, 支持 NCQ、AHCI 和热插拔

## 接口

- 1 x SPI TPM 接脚
- 1 x 机箱侵入和扬声器接脚
- 1 x CPU 风扇接口 (4 针)
- \* CPU 风扇接口支持最高 1A (12W) 功率的 CPU 风扇。
- 1 x 机箱 / 水泵风扇接口 (4 针) (智能风扇速度控制)
- \* 机箱 / 水泵风扇支持最高 2A (24W) 功率的水冷风扇。
- \* CHA\_FAN1/WP 可以自动检测 3 针脚或 4 针脚风扇是否在使用。
- 1 x 24 针 ATX 电源接口
- 1 x 8 针 12V 电源接口
- 1 x 前面板音频接口
- 1 x USB 2.0 接脚 (支持 2 个 USB 2.0 端口, 支持 ESD 保护)
- 1 x USB 3.2 Gen1 接脚 (支持 2 个 USB 3.2 Gen1 端口, 支持 ESD 保护)

## 操作系统

- Microsoft® Windows® 10 64-bit

## 电子信息产品污染控制标示

依据中国发布的「电子信息产品污染控制管理办法」及 SJ/T 11364-2006「电子信息产品污染控制标示要求」，电子信息产品应进行标示，藉以向消费者揭露产品中含有的有毒有害物质或元素不致发生外泄或突变从而对环境造成污染或对人身、财产造成严重损害的期限。依上述规定，您可于本产品之印刷电路板上看见图一之标示。图一中之数字为产品之环保使用期限。由此可知此主板之环保使用期限为 10 年。



图一

## 有毒有害物质或元素的名称及含量说明

若您欲了解此产品的有毒有害物质或元素的名称及含量说明，请参照以下表格及说明。

部件名称	有害物质或元素					
	铅 (Pb)	镉 (Cd)	汞 (Hg)	六价铬 (Cr(VI))	多溴联苯 (PBB)	多溴二苯醚 (PBDE)
印刷电路板及电子组件	X	O	O	O	O	O
外部信号连接头及线材	X	O	O	O	O	O

O: 表示该有毒有害物质在该部件所有均质材料中的含量均在 SJ/T 11363-2006 标准规定的限量要求以下。

X: 表示该有毒有害物质至少在该部件的某一均质材料中的含量超出 SJ/T 11363-2006 标准规定的限量要求，然该部件仍符合欧盟指令 2002/95/EC 的规范。

备注: 此产品所标示之环保使用年限，系指在一般正常使用状况下。

## 規格

平台	<ul style="list-style-type: none"><li>• Micro ATX 尺寸</li><li>• 固態電容設計</li></ul>
CPU	<ul style="list-style-type: none"><li>• 支援第 10 代 Intel® Core™ 處理器 (Socket 1200)</li><li>• Digi Power design</li><li>• 5 電源相位設計</li><li>• 支援 Intel® Turbo Boost MAX 3.0 技術</li></ul>
晶片組	<ul style="list-style-type: none"><li>• Intel® H410</li></ul>
記憶體	<ul style="list-style-type: none"><li>• 雙通道 DDR4 記憶體技術</li><li>• 2 x DDR4 DIMM 插槽</li><li>• 支援DDR4 2933/2800/2666/2400/2133 非 ECC 無緩衝記憶體</li></ul> <p>* 如需更多資訊，請參閱華擎網站上的記憶體支援表。 (<a href="http://www.asrock.com/">http://www.asrock.com/</a>)</p> <p>* Core™ (i9/i7) 支援最高 2933 DDR4;Core™ (i5/i3);Pentium® 和 Celeron® 支援最高 2666 DDR4。</p> <ul style="list-style-type: none"><li>• 支援 ECC UDIMM 記憶體模組 (於非 ECC 模式下運作)</li><li>• 最大系統記憶體容量：64GB</li><li>• 支援 Intel® Extreme Memory Profile (XMP) 2.0</li><li>• 15μ 特厚鍍金插槽</li></ul>
擴充插槽	<ul style="list-style-type: none"><li>• 1 x PCI Express 3.0 x16 插槽</li></ul> <p>* 支援 NVMe SSD 作為開機磁碟</p> <ul style="list-style-type: none"><li>• 1 x PCI Express 3.0 x1 插槽</li></ul>
顯示卡	<ul style="list-style-type: none"><li>• 僅限整合 GPU 的處理器才可支援 Intel® UHD Graphics Built-in Visuals 及 VGA 輸出。</li><li>• 硬體加速編解碼器：AVC/H.264、HEVC/H.265 8 位元、HEVC/H.265 10 位元、VP8、VP9 8 位元、VP9 10 位元、MPEG2、MJPEG、VC-1</li></ul> <p>* VP9 10bit 和 VC-1 僅用於解碼。</p> <p>* Windows 作業系統不支援 VP8 和 VP9 編碼。</p> <ul style="list-style-type: none"><li>• 顯示卡、媒體和運算：Microsoft DirectX 12、OpenGL 4.5、Intel® Built In Visuals、Intel® Quick Sync Video、混合式/可切換顯示卡、OpenCL 2.1</li><li>• 顯示和內容安全性：Rec. 2020 (廣色域)、Microsoft PlayReady 3.0、Intel® SGX 內容保護、UHD/HDR 藍光光碟</li></ul>



H410M-HDV R2.0:

- 三個圖形輸出選項：D-Sub、DVI-D 及 HDMI

\* 最高同時支援 2 台顯示器

- 最高支援 4K x 2K (4096x2160) @ 30Hz 解析度的 HDMI 1.4
- 最高支援 1920x1200 @ 60Hz 解析度的 DVI-D
- 最高支援 1920x1200 @ 60Hz 解析度的 D-Sub
- 支援使用 HDMI 1.4 連接埠 (需相容於 HDMI 顯示器) 的 Auto Lip Sync、Deep Color (12bpc)、xvYCC 及 HBR (高位元率音訊)
- 支援含 DVI-D 及 HDMI 1.4 連接埠的 HDCP 2.3
- 支援使用 HDMI 1.4 連接埠進行 4K Ultra HD (UHD) 播放

H410M-HVS R2.0:

- 雙圖形輸出：透過獨立顯示控制器支援 HDMI 及 D-Sub 連接埠
- 最高支援 4K x 2K (4096x2160) @ 30Hz 解析度的 HDMI 1.4
- 最高支援 1920x1200 @ 60Hz 解析度的 D-Sub
- 支援使用 HDMI 1.4 連接埠 (需相容於 HDMI 顯示器) 的 Auto Lip Sync、Deep Color (12bpc)、xvYCC 及 HBR (高位元率音訊)
- 支援含 HDMI 1.4 連接埠的 HDCP 2.3
- 支援使用 HDMI 1.4 連接埠進行 4K Ultra HD (UHD) 播放

音訊

- 7.1 CH HD 音訊 (Realtek ALC887/897 音訊轉碼器)
- 支援突波保護

LAN

- Gigabit LAN 10/100/1000 Mb/s
- Giga PHY Intel® I219V
- 支援網路喚醒
- 支援雷擊/靜電保護
- 支援 802.3az EEE 節能乙太網路
- 支援 PXE

## 後面板 I/O

- 1 x PS/2 滑鼠／鍵盤連接埠
- 4 x USB 2.0 連接埠 (支援靜電保護)
- 2 x USB 3.2 Gen1 連接埠 (支援靜電保護)
- 1 x RJ-45 LAN 連接埠，含 LED (ACT/LINK LED 及 SPEED LED)
- HD 音訊插孔：線路輸入／前置喇叭／麥克風

## H410M-HDV R2.0:

- 1 x D-Sub 連接埠
- 1 x DVI-D 連接埠
- 1 x HDMI 連接埠

## H410M-HVS R2.0:

- 1 x D-Sub 連接埠
- 1 x HDMI 連接埠

## 儲存裝置

- 4 x SATA3 6.0 Gb/s 接頭，支援 NCQ、AHCI 及「熱插拔」

## 接頭

- 1 x SPI TPM 排針
- 1 x 機殼防護及喇叭排針
- 1 x CPU 風扇接頭 (4-pin)
- \* CPU 風扇接頭支援最高 1A (12W) 風扇功率的 CPU 風扇。
- 1 x 機殼／水冷幫浦風扇接頭 (4-pin) (智慧型風扇速度控制)
- \* 機殼／水冷幫浦風扇接頭支援最高 2A (24W) 風扇功率的水冷風扇。
- \* 如果 3-pin 或 4-pin 風扇使用中，可自動偵測 CHA\_FAN1/WP。
- 1 x 24 pin ATX 電源接頭
- 1 x 8 pin 12V 電源接頭
- 1 x 前面板音訊接頭
- 1 x USB 2.0 排針 (支援 2 個 USB 2.0 連接埠) (支援靜電保護)
- 1 x USB 3.2 Gen1 排針 (支援 2 個 USB 3.2 Gen1 連接埠) (支援靜電保護)

## 作業系統

- Microsoft® Windows® 10 64-bit

## Spesifikasi

### Platform

- Bentuk dan Ukuran Micro ATX
- Desain Kapasitor Solid

### CPU

- Mendukung Prosesor Generasi ke-10 Intel® Core™ (Soket 1200)
- Desain Digi Power
- Desain 5 Fase Daya
- Mendukung Teknologi Intel® Turbo Boost MAX 3.0

### Chipset

- Intel® H410

### Memori

- Teknologi Memori DDR4 Dua Saluran
- 2 x Slot DIMM DDR4
- Mendukung DDR4 2933/2800/2666/2400/2133 non-ECC, memori tanpa buffer
- \* Lihat Daftar Dukungan Memori pada situs web ASRock untuk informasi selengkapnya. (<http://www.asrock.com/>)
- \* Core™ (i9/i7) mendukung DDR4 hingga 2933; Core™ (i5/i3), Pentium® dan Celeron® mendukung DDR4 hingga 2666.
- Mendukung modul memori ECC UDIMM (berjalan dalam mode non-ECC)
- Kapasitas maksimum memori sistem: 64GB
- Mendukung Intel® Extreme Memory Profile (XMP) 2.0
- 15µ Bidang Kontak Berwarna Emas di Slot DIMM

### Slot Ekspansi

- 1 x Slot PCI Express 3.0 x16
- \* Mendukung SSD NVMe sebagai disk boot
- 1 x Slot PCI Express 3.0 x1

### Grafis

- Intel® UHD Graphics Built-in Visuals dan output VGA hanya didukung dengan prosesor yang terintegrasi GPU.
- Codec Yang Dipercepat Hardware: AVC/H.264, HEVC/H.265 8-bit, HEVC/H.265 10-bit, VP8, VP9 8-bit, VP9 10-bit, MPEG2, MJPEG, VC-1
- \* VP9 10bit dan VC-1 hanya untuk mendekode.
- \* Enkode VP8 dan VP9 tidak didukung oleh Windows OS.
- Grafis, Media & Hitung: Microsoft DirectX 12, OpenGL 4.5, Visual Internal Intel®, Video Sinkronisasi Ceoat Intel®, Grafik Hybrid / Yang Bisa Dialihkan, OpenCL 2.1

- Tampilan & Keamanan Konten: Rec. 2020 (Nuansa Banyak Warna), Microsoft PlayReady 3.0, Perlindungan Konten Intel® SGX, UHD/HDR Blu-ray Disc

#### **H410M-HDV R2.0 R2.0:**

- Tiga pilihan output grafis: D-Sub, DVI-D, dan HDMI
- \* Mendukung hingga 2 tampilan secara bersamaan
- Mendukung HDMI 1.4 dengan resolusi maksimum hingga 4K x 2K (4096x2160) @ 30Hz
- Mendukung DVI-D dengan resolusi maksimum hingga 1920x1200 @ 60Hz
- Mendukung D-Sub dengan resolusi maksimum hingga 1920x1200 @ 60Hz
- Mendukung Auto Lip Sync, Kedalaman Warna (12bpc), xvYCC, dan HBR (Audio High Bit Rate) dengan Port HDMI 1.4 (memerlukan monitor yang kompatibel dengan HDMI)
- Mendukung HDCP 2.3 dengan port DVI-D dan HDMI 1.4
- Mendukung pemutaran Ultra HD 4K (UHD) dengan Port HDMI 1.4

#### **H410M-HVS R2.0:**

- Output grafis ganda: Mendukung port HDMI dan D-Sub dengan kontrol layar independen
- Mendukung HDMI 1.4 dengan resolusi maksimum hingga 4K x 2K (4096x2160) @ 30Hz
- Mendukung D-Sub dengan resolusi maksimum hingga 1920x1200 @ 60Hz
- Mendukung Auto Lip Sync, Kedalaman Warna (12bpc), xvYCC, dan HBR (Audio High Bit Rate) dengan Port HDMI 1.4 (memerlukan monitor yang kompatibel dengan HDMI)
- Mendukung fungsi HDCP 2.3 dengan Port HDMI 1.4
- Mendukung pemutaran Ultra HD 4K (UHD) dengan Port HDMI 1.4

#### **Audio**

- Audio HD 7.1 CH (Realtek ALC887/897 Audio Codec)
- Mendukung Perlindungan dari Lonjakan Arus

#### **LAN**

- Gigabit LAN 10/100/1000 Mb/s
- Giga PHY Intel® I219V
- Mendukung Wake-On-LAN

- Mendukung Perlindungan dari Petir/ESD
- Mendukung Ethernet 802.3az Hemat Energi
- Mendukung PXE

#### **I/O Panel Belakang**

- 1 x Port Mouse/Keyboard PS/2
- 4 x Port USB 2.0 (Mendukung Perlindungan dari ESD)
- 2 x Port USB 3.2 Gen1 (Mendukung Perlindungan dari ESD)
- 1 x Port LAN RJ-45 dengan LED (LED ACT/LINK dan LED SPEED)
- Soket Audio HD: Saluran Masuk/Speaker Depan/Mikrofon

#### **H410M-HDV R2.0 R2.0:**

- 1 x Port D-Sub
- 1 x Port DVI-D
- 1 x Port HDMI

#### **H410M-HVS R2.0:**

- 1 x Port D-Sub
- 1 x Port HDMI

#### **Penyimpanan**

- 4 x Konektor SATA3 6,0 Gb/s, mendukung NCQ, AHCI, dan Hot Plug

#### **Konektor**

- 1 x Header SPI TPM
- 1 x Intrusi Chassis dan Header Speaker
- 1 x Konektor Kipas CPU (4-pin)
- \* Konektor Kipas CPU mendukung kipas CPU dengan daya kipas maksimum 1A (12W).
- 1 x Konektor Kipas Chassis/Pompa Air (4-pin) (Kontrol Kecepatan Kipas Pintar)
- \* Chassis/Kipas Pompa Air mendukung kipas berpendingin air dengan daya kipas maksimum 2A (24W).
- \* CHA\_FAN1/WP dapat mendeteksi otomatis jika kipas 3-pin atau 4-pin sedang digunakan.
- 1 x Konektor Daya ATX 24 pin
- 1 x Konektor Daya 8 pin 12V
- 1 x Konektor Audio Panel Depan
- 1 x Header USB 2.0 (Mendukung 2 port USB 2.0) (Mendukung Perlindungan dari ESD)
- 1 x Header USB 3.2 Gen1 (Mendukung 2 port USB 3.2 Gen1) (Mendukung Perlindungan dari ESD)

#### **OS**

- Microsoft® Windows® 10 64-bit

## Contact Information

If you need to contact ASRock or want to know more about ASRock, you're welcome to visit ASRock's website at <http://www.asrock.com>; or you may contact your dealer for further information. For technical questions, please submit a support request form at <http://www.asrock.com/support/tsd.asp>

### **ASRock Incorporation**

2F., No.37, Sec. 2, Jhongyang S. Rd., Beitou District,  
Taipei City 112, Taiwan (R.O.C.)

### **ASRock EUROPE B.V.**

Bijsterhuizen 11-11

6546 AR Nijmegen

The Netherlands

Phone: +31-24-345-44-33

Fax: +31-24-345-44-38

### **ASRock America, Inc.**

13848 Magnolia Ave, Chino, CA91710

U.S.A.

Phone: +1-909-590-8308

Fax: +1-909-590-1026

# DECLARATION OF CONFORMITY

Per FCC Part 2 Section 2.1077(a)



**Responsible Party Name:** ASRock Incorporation

**Address:** 13848 Magnolia Ave, Chino, CA91710

**Phone/Fax No:** +1-909-590-8308/+1-909-590-1026

hereby declares that the product

**Product Name :** Motherboard

**Model Number :** H410M-HDV R2.0 / H410M-HVS R2.0

Conforms to the following specifications:

FCC Part 15, Subpart B, Unintentional Radiators

## Supplementary Information:

This device complies with part 15 of the FCC Rules. Operation is subject to the following two conditions: (1) This device may not cause harmful interference, and (2) this device must accept any interference received, including interference that may cause undesired operation.

Representative Person's Name: James

Signature:

A handwritten signature in black ink, appearing to read 'James', written over a horizontal line.

Date : May 12, 2017

# EU Declaration of Conformity



For the following equipment:

## Motherboard

(Product Name)

**H410M-HDV R2.0 / H410M-HVS R2.0 / ASRock**

(Model Designation / Trade Name)

## ASRock Incorporation

(Manufacturer Name)

**2F., No.37, Sec. 2, Jhongyang S. Rd., Beitou District, Taipei City 112, Taiwan (R.O.C.)**

(Manufacturer Address)

**EMC — Directive 2014/30/EU (from April 20th, 2016)**

EN 55022:2010/AC:2011 Class B

EN 55024:2010/A1:2015

EN 55032:2012+AC:2013 Class B

EN 61000-3-3:2013

EN 61000-3-2:2014

**LVD — Directive 2014/35/EU (from April 20th, 2016)**

EN 60950-1 : 2011+ A2: 2013

EN 60950-1 : 2006/A12: 2011

RoHS — Directive 2011/65/EU

CE marking

(EU conformity marking)



## ASRock EUROPE B.V.

(Company Name)

**Bijsterhuizen 1111 6546 AR Nijmegen The Netherlands**

(Company Address)

Person responsible for making this declaration:

(Name, Surname)

**A.V.P**

(Position / Title)

**December 25, 2020**

(Date)

P/N: 15G062262000AK V1.0