

Warranty

Conditions of Warranty

1. JPL Telecom Limited grants 24 months Manufacturer's Warranty from the date of purchase, as the manufacturer of this product.
2. For you, as a consumer, this means: We guarantee that our devices are error-free when supplied. If a manufacturing error is identified within 24 months of the delivery date we will repair or replace the device free of charge without you, as the consumer, having to provide the usual legally required proof that this fault was present when you received the device. We either use new parts or parts in mint condition for the repair or replacement delivery. Any parts removed from the device become our property and can be destroyed by us.
3. In addition to this warranty, you have the unlimited legal right to claim against the supplier on the basis of the terms of the warranty for defects on the basis of the purchase contract. However, in contrast to our Manufacturer's Warranty, the legal warranty for defects only applies to the device's state when sold.
4. You can only claim against this warranty if you return the faulty device to JPL Telecom Limited or our local general importer or distributor, outside the UK, at your own cost, with a valid proof of purchase (invoice or till receipt). When you return it to us, please provide a detailed description of the fault that has occurred, and also tell us your telephone number, in case we need to contact you. To prevent shipping damage, provide suitable transport packaging (e.g. original packaging with a secondary shipping box).
5. The Manufacturer's Warranty excludes damage caused by mishandling, operating errors, misuse, external influences, lightning strikes/power surges, modifications to the product and extensions. Also excluded are wearing parts (e.g. ear cushions, wind shield). Shipping damage, consequential damage, and costs arising from down times and travel times are also excluded.
6. The warranty is cancelled if repairs are carried out by unauthorised agents.

Environmental Notice

If you want to dispose of the device, please ensure its professional disposal. Do not put it in the normal household waste.

Dispose of the packaging material properly and in interest of the environmental protection.

Consult your responsible authority for information about the professional and environment-friendly disposal of your device. If you want that we handle the disposal for you, you can send the device at your costs to JPL Telecom Limited.

General Limitation of Liability

The device is not designed, manufactured, or intended for use or resale, in environments that require fail-safe performance, such as in the operation of life-support systems and/or nuclear facilities. The device may only be used for these purposes with prior written permission from the manufacturer in each individual case.

Declaration of Conformity

This device complies with the basic health, safety and environmental requirements in all relevant EU directives. You will find the Declaration of Conformity on our website.

Warning

Ensure that all electrical connections (including extension leads and interconnections between pieces of equipment) are properly made and in accordance with the relevant manufacturers instructions.

- Do not continue to operate the equipment if you are in any doubt about it working normally, or if it is damaged in any way. Disconnect from your telephone equipment and consult your dealer.
- Do not allow electrical equipment to be exposed to rain or moisture.
- Never push anything into holes, slots or any other opening on your headset as this could result in fatal electrical shock.
- Do not open the headset housing as doing so will void the warranty.
- Never guess or take chances with electrical equipment.
- Do not use this equipment to report a gas leak while you are in the vicinity of a gas leak.
- Telephone headsets are capable of producing high levels of sound. Prolonged exposure to high sound levels can cause damage to hearing.
- Never allow small children to play with the headset - small parts may be a choking hazard.

Safety

For your own safety, this product should only be used with CE ACA and RoHS approved equipment. Using this headset with non approved equipment can void this products warranty.

REGISTERED ADDRESS

UK Office: JPL Telecom Limited: Unit 1, Church Close Business Park, Todber, Sturminster Newton, Dorset, DT10 1JH, UK
USA Office: JPL Telecom Holdings LLC: 445 W Merritt Ave, Merritt Island, FL 32953, USA

Registered in England No. 5250754

www.jpltele.com



QUICK START GUIDE

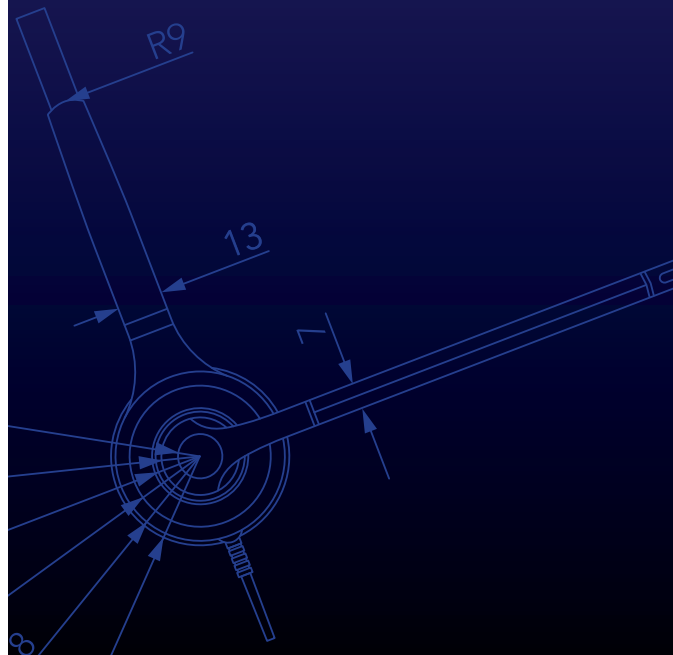

Quick Start Guide

For full operating instructions please visit www.jpltele.com

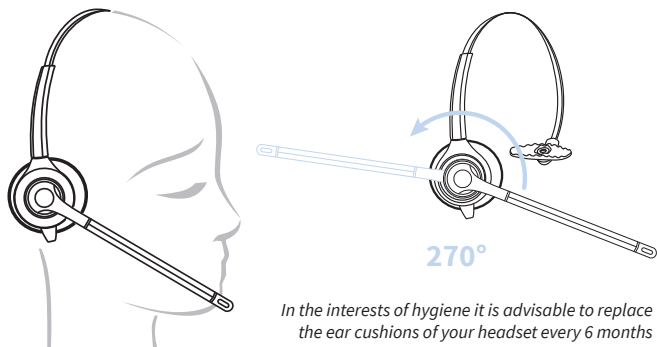

In the interests of hygiene it is advisable to replace the ear cushions of your headset every 6 months

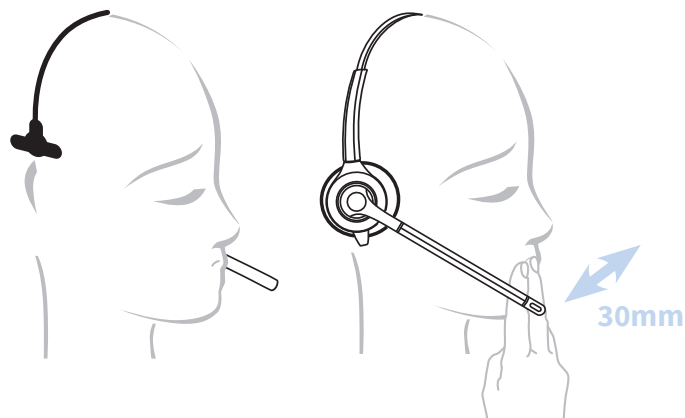

*Headset supplied with top lead only.
All headsets require an additional bottom lead.
Please check the compatibility chart on
www.jpltele.com for the correct
bottom lead for your phone.*

