



MINIATURE BREAKERS OF M06N AND M10N TYPES AND ARMAT SERIES

Operation manual

Product designation

Circuit breakers of M06N and M10N types and ARMAT series of IEK trade mark (hereinafter referred to as – circuit breakers) are designed for switching electrical circuits with voltage up to 400 V AC and frequency 50 Hz.

The circuit breakers perform the functions of automatic disconnection of the electric installation in the event of overcurrents (overload or short circuit) and of on-line control of electrical circuit sections from overcurrents.

Main scope of circuit breakers

- Distribution switchboard (DS);
- Branch-circuit panel board (housing and floor);
- Individual electricity consumers.

Type designation

ARMAT Circuit breaker MX1N X2 X3 X4 IEK  
 ARMAT – series;  
 M – (MCB) – circuit breaker;  
 X1 – breaking capacity: 6 – 6 kA; 10 – 10 kA;  
 N – frame size (module width) – 18 mm;  
 X2 – quantity of poles: 1P – one pole; 2P – two poles;  
 3P – three poles; 4P – four poles;  
 X3 – safety features type: B; C; D;  
 X4 – rated current designation: 0,5A; 1A; 1,6A; 2A; 2,5A; 3A; 4A; 5A; 6A; 8A; 10A; 13A; 16A; 20A; 25A; 32A; 40A; 50A; 63A.

IEK – trade mark.  
 Record example:  
 ARMAT Circuit breaker M06N 1P B 16A IEK

Technical characteristics and operation conditions

Parameter denomination	For circuit breakers of type	
	M06N	M10N
Rated short-circuit breaking capacity I <sub>cn</sub> , kA	6	10
Service short-circuit breaking capacity I <sub>cs</sub> , kA	6	7,5
Service breaking capacity		
Rated ultimate short-circuit breaking capacity I <sub>cu</sub> according to IEC60947-2, A	0,5 ≤ I <sub>n</sub> ≤ 4 A	50000
	6 ≤ I <sub>n</sub> ≤ 20 A	15000
	25 ≤ I <sub>n</sub> ≤ 63 A	10000
Quantity of poles	1, 2, 3, 4	
Presence of overcurrent protection in the poles	In all poles	
AC rated operational voltage U <sub>e</sub> , V	1-, 2-poles	230/400
	3-, 4-poles	400
Rated mains frequency , Hz	50	
Rated current I <sub>n</sub> , A	0,5; 1; 1,6; 2; 2,5; 3; 4; 5; 6; 8; 10; 13; 16; 20; 25; 32; 40; 50; 63	
Rated impulse withstand voltage U <sub>imp</sub> , kV	6	
Operating temperature range, °C	from –40 to 70	
Base altitude, m	2000	
Overcurrent tripping characteristics, type	B, C, D	
Mechanical wear resistance, On-Off cycles	20000	
Electrical wear resistance, On-Off cycles	10000	
Electric shock protection class	0	
Degree of protection according to IEC 60529	IP20	
Structural design category	M4	
Cross-section of the wire connected to the terminals, mm <sup>2</sup>	1...25	
	recommendet maximum	2,5±0,5
Tightening torque for terminal screws, N·m	3,5	
Possibility of connection to terminals of connecting bus	PIN (pin); FORK (plug)	
Operation position	any	
Weight of 1 pole, kg, not more	0,116	
Supply lead	From any side	
Contact position indicator (on front panel)	There is	
Relative humidity at 20 °C, %	90	
Operation position	any	

The joints should be clean and free of burrs. It is allowed, if necessary, to bend the cable lugs to ensure the installation of external conductors.

When terminating conductors with cable lugs, it is imperative to use insulating tubes or adhesive tapes.

The contact screw clamps of the circuit breakers allow the connection of copper or aluminum conductors with a cross section of no more than 25 mm<sup>2</sup> or connecting busbars of the PIN (pin) and FORK (plug) types.

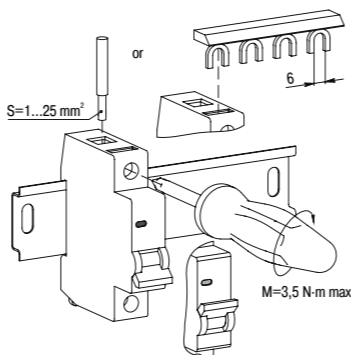

Maintenance

Under normal operating conditions, the breaker should be inspected once a year. Regardless of this, the circuit breaker should be inspected after each short-circuit current interruption.

During inspection is carried out:

- removal of dust and dirt;
- checking the reliability of fixing the circuit breaker to the structure;
- tightening the screws of the clamps of the main and auxiliary contacts;
- circuit breaker closing and opening manually without load;
- checking the performance of the circuit breaker in assembly with facilities when testing it in operating modes.

The circuit breakers are not repairable. If faulty, they should be replaced.

Transportation, storage and disposal

Transportation is allowed by any type of transport at a temperature from minus 25 °C to 55 °C and a relative humidity of 90 % at 20 °C.

Transportation of circuit breakers is allowed by any type of roofed transport in the manufacturer's package, which protects the packed circuit breakers from mechanical damages, dirt and moisture ingress.

Storage of circuit breakers is carried out only in the manufacturer's package in rooms with natural ventilation at an ambient temperature of minus 25 °C to 55 °C and a relative humidity of no more than 90 % at a temperature of 20 °C. Storage is allowed at a relative humidity of 50 % and a temperature of 40 °C.

Disposal of products is carried out by transferring the circuit breakers and their parts to specialized organizations.

Time-current performance at calibration reference temperature 30 °C

Thermal release	1,13 I <sub>n</sub> : t <sub>cp</sub> ≤ 1 h – without release	
	1,45 I <sub>n</sub> : t <sub>cp</sub> < 1 h – release	
	2,55 I <sub>n</sub> : 1 s < t <sub>cp</sub> < 60 s – (at I <sub>n</sub> ≤ 32 A) – release	
	1 s < t <sub>cp</sub> < 120 s - (at I <sub>n</sub> > 32 A) – release	
Electromagnetic release	B	3 I <sub>n</sub> : t <sub>cp</sub> ≤ 0,1 s – without release
		5 I <sub>n</sub> : t <sub>cp</sub> < 0,1 s – release
	C	5 I <sub>n</sub> : t <sub>cp</sub> ≤ 0,1 s – without release
		10 I <sub>n</sub> : t <sub>cp</sub> < 0,1 s – release
	D	10 I <sub>n</sub> : t <sub>cp</sub> ≤ 0,1 s – without release
		20 I <sub>n</sub> : t <sub>cp</sub> < 0,1 s – release

Influence of the ambient temperature on the operation of the thermal release

I <sub>n</sub> , A	Current value, A, at the ambient temperature, °C												
	-40	-30	-20	-10	0	10	20	30	40	50	60	70	
0,5	0,67	0,65	0,63	0,60	0,58	0,56	0,53	0,5	0,47	0,44	0,41	0,38	
1	1,33	1,29	1,25	1,20	1,15	1,11	1,05	1	0,94	0,88	0,82	0,75	
1,6	2,14	2,06	1,99	1,92	1,85	1,77	1,69	1,6	1,51	1,41	1,30	1,19	
2	2,67	2,58	2,49	2,40	2,31	2,21	2,11	2	1,89	1,76	1,63	1,49	
2,5	3,33	3,25	3,08	3,00	2,92	2,75	2,67	2,5	2,33	2,17	2,00	1,83	
3	4,00	3,90	3,70	3,60	3,50	3,30	3,20	3	2,80	2,60	2,40	2,20	
4	5,30	5,20	5,00	4,80	4,60	4,40	4,20	4	3,80	3,50	3,30	3,00	
6	8,00	7,70	7,50	7,20	6,90	6,60	6,30	6	5,70	5,30	4,90	4,50	
8	10,70	10,30	10,00	9,60	9,20	8,80	8,40	8	7,50	7,10	6,50	6,00	
10	13,30	12,90	12,50	12,00	11,50	11,10	10,50	10	9,40	8,80	8,20	7,50	
16	21,30	20,70	20,00	19,20	18,50	17,70	16,90	16	15,10	14,10	13,10	11,90	
20	26,70	25,80	24,90	24,00	23,10	22,10	21,10	20	18,90	17,60	16,3	14,90	
25	33,30	32,30	31,20	30,00	28,90	27,60	26,40	25	23,60	22,00	20,40	18,60	
32	42,70	41,30	39,90	38,50	37,00	35,40	33,70	32	30,20	28,20	26,10	23,90	
40	53,30	51,60	49,90	48,10	46,20	44,20	42,20	40	37,70	35,30	32,70	29,80	
50	66,70	64,50	62,40	60,10	55,30	55,30	52,70	50	47,10	44,10	40,80	37,30	
63	84,00	81,30	78,60	75,70	72,70	69,60	66,40	63	59,40	55,60	51,40	47,00	

Service life and manufacturer's warranty

Circuit breaker service life – 15 years.

Circuit breaker warranty period – 10 years from the date of sale under observance by consumer of transportation, storage and operation rules.

If you have any claims during the warranty period, contact the seller or organization:

**Russian Federation**  
**«IEK HOLDING» LLC**  
 107/49 Prospect Lenina, office 457, Podolsk, Moscow region, 142100  
 Tel./fax: +7 (495) 542-22-27  
 info@iek.ru  
 www.iek.ru

**Mongolia**  
**«IEK Mongolia» LLC**  
 ul. Moskovskaya, 9, Zapadnaya zona promyshlennogo rayona 16100, 20 uchastok Bayangolyskogo rayona, Ulan Bator  
 Tel.: +976 7015-28-28  
 Fax: +976 7016-28-28  
 info@iek.mn  
 www.iek.mn

**Republic of Moldova**  
**«IEK TRADE» L.L.C.**  
 21 Maria Dragan str., Chisinau, MD-2044  
 Tel.: +373 (22) 479-065, 479-066  
 Fax: +373 (22) 479-067  
 info@iek.md; infomd@md.iek.ru  
 www.iek.md

**Asian countries**  
**Republic of Kazakhstan**  
**«TD IEK. KAZ» JShS**  
 040916, Almaty oblysy, Qarasai aydany, Irgeli ayyly, Aqjol yqsh. ayd., 71A  
 Tel.: +7 (727) 237-92-49, 237-92-50  
 infokz@iek.ru  
 www.iek.kz

**Ukraine**  
**«TRADE HOUSE UKRELEKTROKOMPLEKT» LLC**  
 ul. Kievskaya, 6 V, Vishnyovoe, Kyivo-Svyatoshynskiy rayon, Kyiv oblast, 08132  
 Tel.: +38 (044) 536-99-00  
 info@iek.com.ua  
 www.iek.ua

**EU countries**  
**Republic of Latvia**  
**LLC «IEK Baltia»**  
 11, Rankas str., Riga, LV-1005  
 Tel.: +371 2934-60-30  
 iek-baltija@inbox.lv  
 www.iek.lv

**Republic of Belarus**  
**LLC «IEK HOLDING»**  
 (Representative office in the Republic of Belarus)  
 220025, Minsk, ul. Shafarnyanskaya, d. 11, room 62  
 Tel.: +375 (17) 286-36-29  
 iek.by@iek.ru  
 www.iek.ru

Overall and mounting dimensions

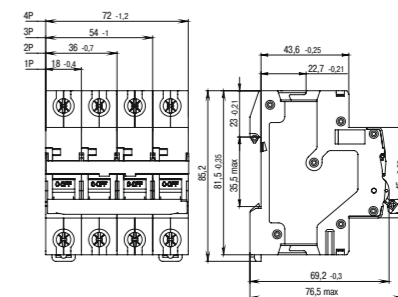

Electric schematic diagrams

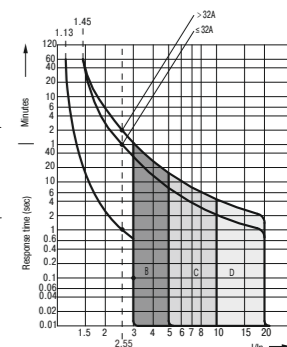

Time-current performances

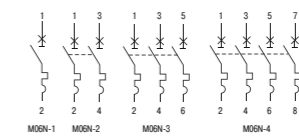

Structure and function

The circuit breaker consists of the following main components: a drive mechanism, a trip-free mechanism, a contact combination, an arc-control device, electromagnetic and thermal overcurrent releases.

The switching position of the circuit breaker is indicated by the position of its control element and the color of the indicator:

- on position – by the sign "I", indicator is red;
- off position – by "O" sign, green indicator.

Circuit breaker tripping in case of overloads, short circuits occurs regardless of whether the handle is held in the on position or not.

Completeness of set

Name	Quantity, pcs. (copies) in the package			
	1-poles	2- poles	3- poles	4- poles
Circuit breaker	12	6	4	3
Manual	1			

Auxiliary devices

AR-AUX-UR-220	ARMAT Under-voltage release AR-AUX 220...240 V IEK
AR-AUX-URT-220	ARMAT Under-voltage release with delay time AR-AUX 220...240 V IEK
AR-AUX-SR-100-415	ARMAT Shunt release AR-AUX 100...415 V IEK
AR-AUX-SR-48	ARMAT Shunt release AR-AUX 48 V IEK
AR-AUX-SR-12-24	ARMAT Shunt release AR-AUX 12...24 V IEK
AR-AUX-SR-100-415-I	ARMAT Shunt release with display AR-AUX 100...415 V IEK
AR-AUX-SR-48-I	ARMAT Shunt release with display AR-AUX 48 V IEK
AR-AUX-SR-12-24-I	ARMAT Shunt release with display AR-AUX 12...24 V IEK
AR-AUX-OR-220-240	ARMAT Overvoltage release AR-AUX 220...240 V IEK
AR-AUX-SC-240-415	ARMAT State contact AR-AUX 240...415 V IEK
AR-AUX-AC-240-415	ARMAT Auxiliary contact AR-AUX 240...415 V IEK
AR-AUX-DC-240-415	ARMAT Make-and-break contact AR-AUX 240...415 V IEK

Safety precautions

The operation of the circuit breaker should be carried out in accordance with the "Regulations for Electrical Installation", "Rules of technical operation of electric installations of consumers" and "Interbranch rules on labor safety in operation of electricity generating equipment".

All installation and service maintenance should be carried out in de-energized state.

According to the method of protection against electric shock, the circuit breakers correspond to class 0 and should be installed in switchgears with a protection class of at least I.

IT IS FORBIDDEN

To use circuit breakers when arising of cracks or chips on the case during operation.

Installation

The circuit breakers allow voltage supply from the power source both from the side of outputs 1, 3, 5, 7, and from the side of outputs 2, 4, 6, 8.

When connecting the conductors, care must be taken to ensure that they do not create forces that bend off the outputs.

All connected conductors and cable lugs are tightly tightened to the clamps of contacts.

