

ODEON RIVE GAUCHE

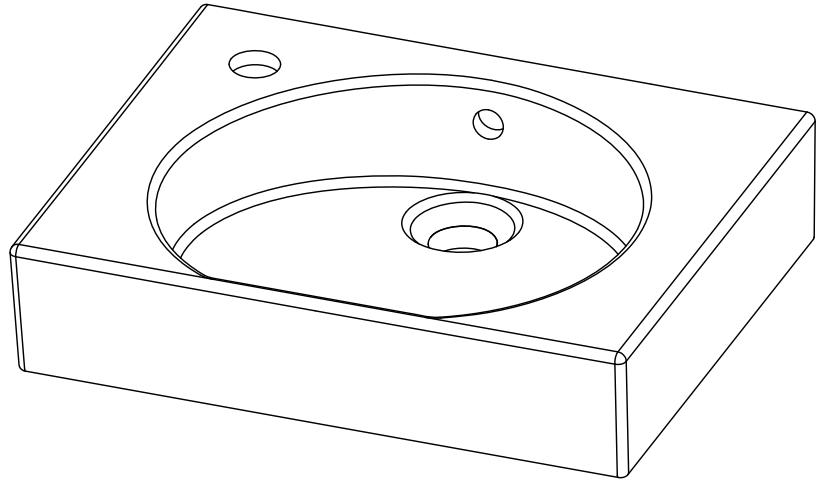

450x360: EGN112

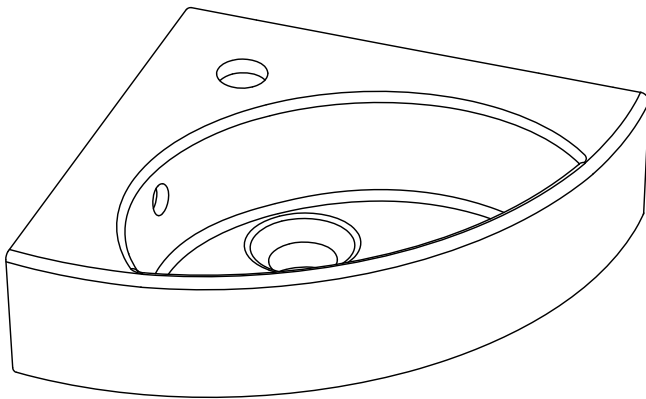

340x340: EGP112

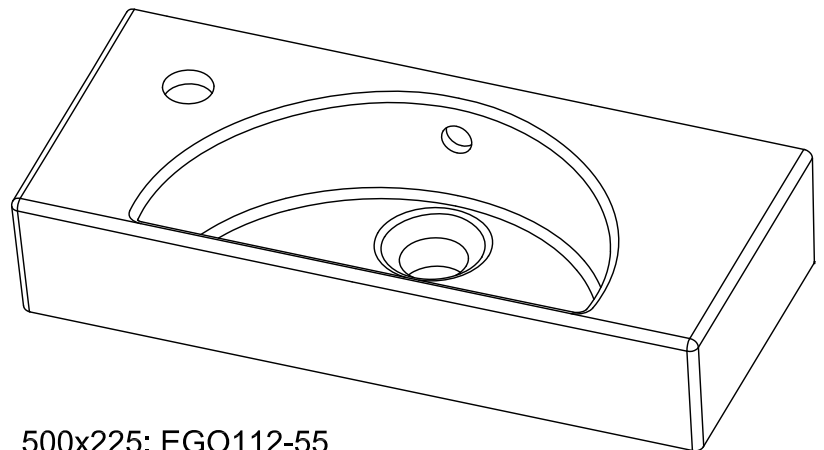

500x225: EGO112-55
500x225: EGO112-56

Jacob Delafon
PARIS

UK

Make sure that the item is installed by a competent installer. We strongly recommend that all glass panels are moved by a minimum of two people and that protective packaging along the glass edges is kept in place for as long as possible to prevent damage before installation. Wear protective footwear when lifting panels. Wear safety glasses when drilling. Observe all local plumbing and building codes.

FR

Assurez-vous que le produit est installé par une personne compétente. Nous conseillons la manutention de tous les panneaux en verre par deux personnes au minimum. Il est recommandé de laisser tous les emballages de protection en place sur les arêtes en verre. Porter des chaussures de sécurité lors de la manutention des panneaux. Porter des lunettes de protection lors du perçage. Respecter tous les codes nationaux du bâtiment et de la plomberie.

ES

Asegúrese que el producto es instalado por personal preparado. Les aconsejamos que haya al menos dos personas para manejar los paneles. Es recomendable dejar todos los embalajes de protección y poner sobre ellos los paneles. Lleve zapatos de seguridad mientras se manipule los paneles. Colocarse gafas de protección a la hora de hacer agujeros. Respete las normas nacionales de construcción y fontanería.

RU

Убедитесь, что продукт установлен компетентным специалистом. Мы настоятельно рекомендуем перемещать все стеклянные панели бригадой в составе как минимум двух человек и не удалять защитную пленку со стекла в течение всего периода монтажа, чтобы предотвратить повреждения. Носите защитную обувь при перемещении панелей. Носите защитные очки при сверлении. Соблюдайте все локальные строительные-технологические нормы.

RPC

请确保商品是由具备相应能力的安装人员进行安装。我们强烈建议至少 2 人一起移动玻璃面板，并尽可能在安装前将玻璃边缘的防护包装固定就位，以防出现损坏。抬举面板时请着防护鞋具。钻孔时请佩戴护目镜。施工时请遵守当地所有管道及建筑规范。

ME

تأكد من أن يتم تثبيت المنتج من قبل شخص مختص. ننصح بأن يتم حمل اللوحات الزجاجية من طرف شخصين على الأقل. نوصي بترك جميع تغليفات الحماية في مكانها على الأطراف الزجاجية. ارتداء حذاء السلامة عند حمل اللوحات الزجاجية. ارتداء نظارات واقية عند الحفر. إحترام جميع القوانين المتعلقة بالبناء والسبابة

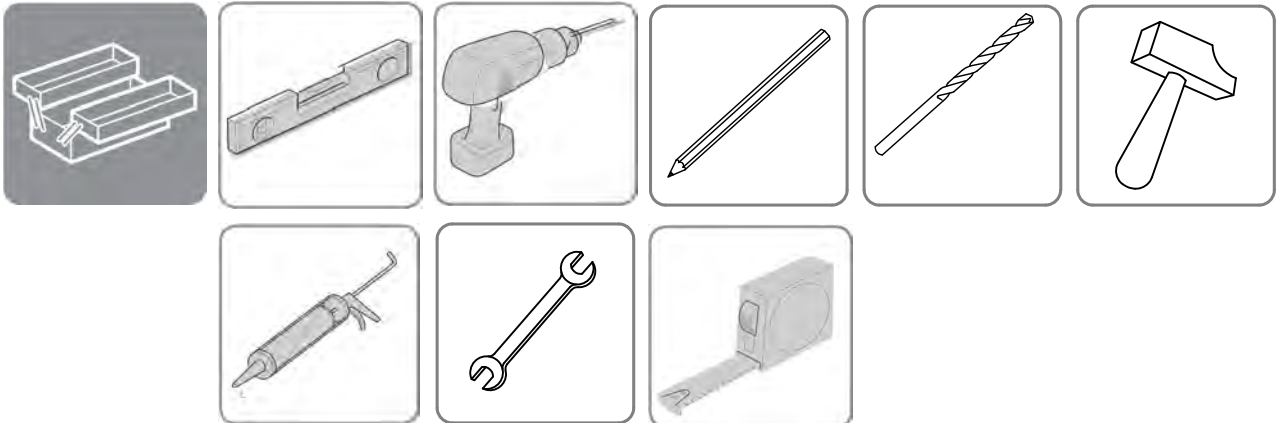



EGO112-55 / EGO112-56

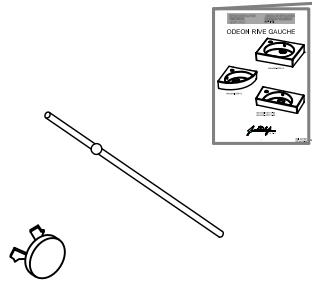
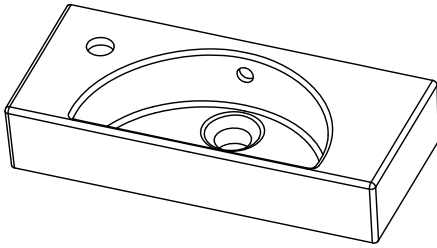

EGN112

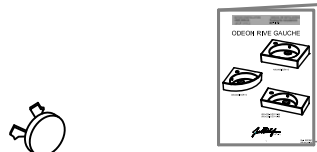
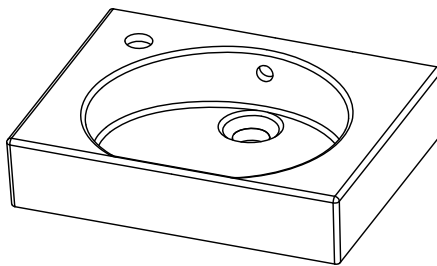

EGP112

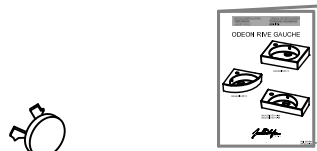
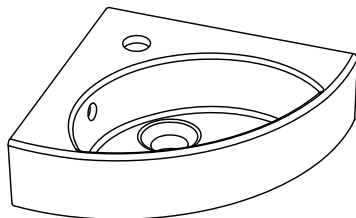



1- EGN112 / EGO112

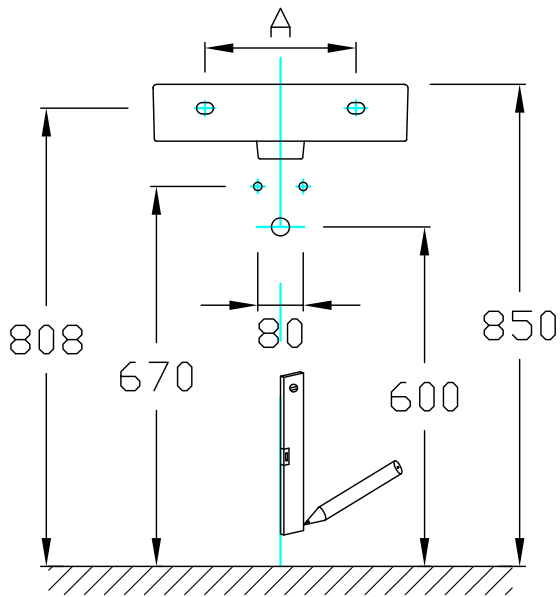

	A
450x360: EGN112	266mm
500x225: EGO112-55 EGO112-56	310mm

1- EGP112

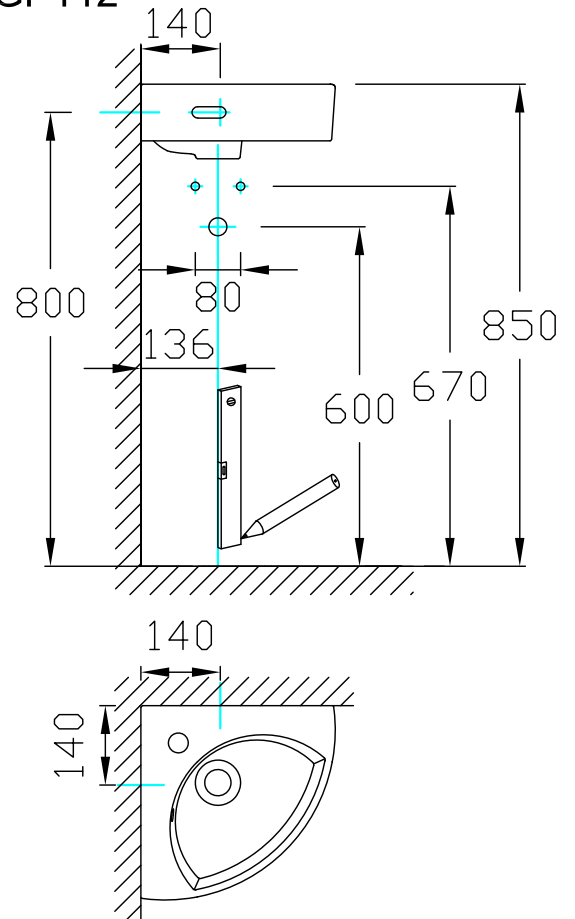

2

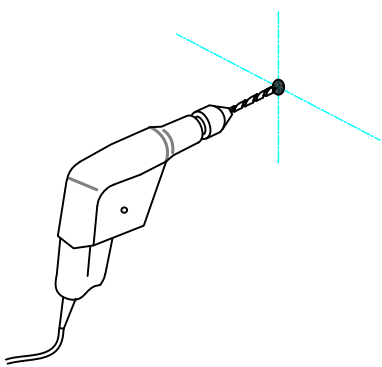

3

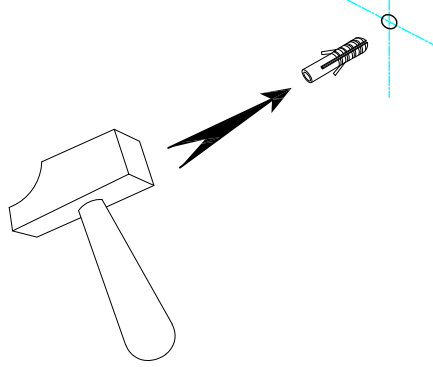

4

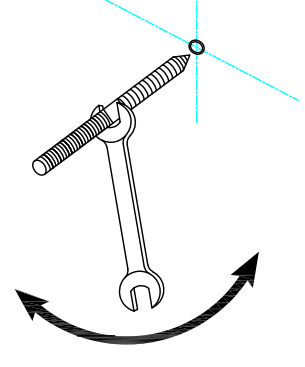

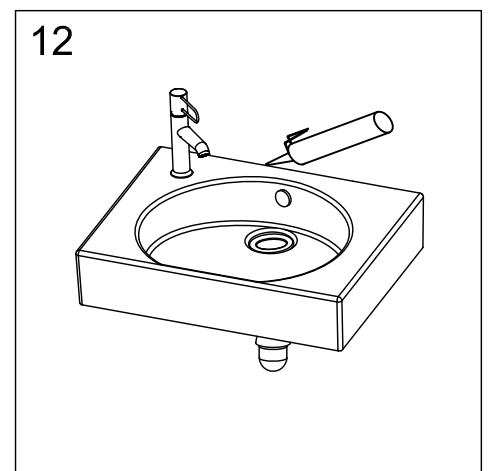
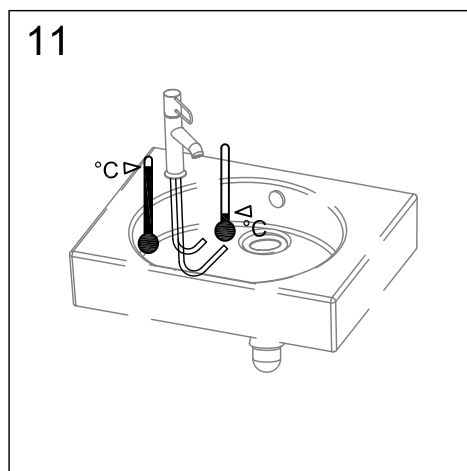
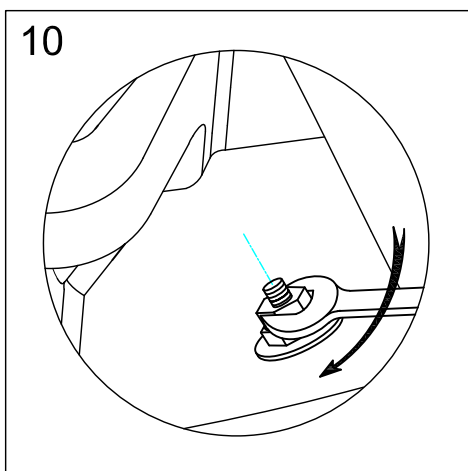
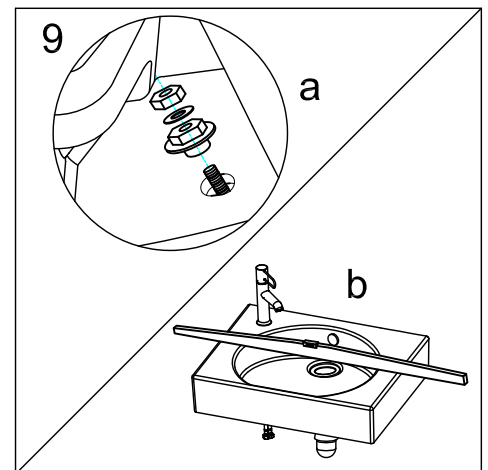
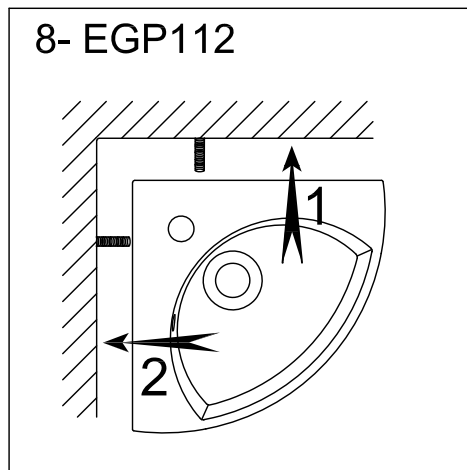
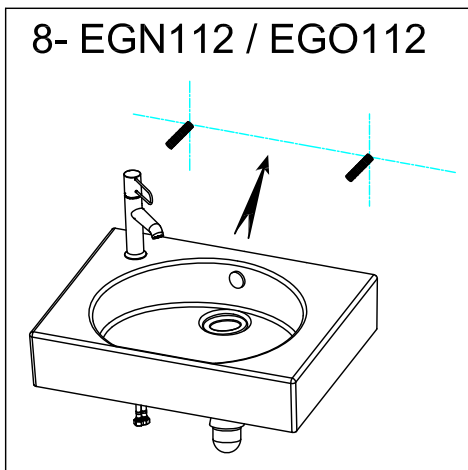
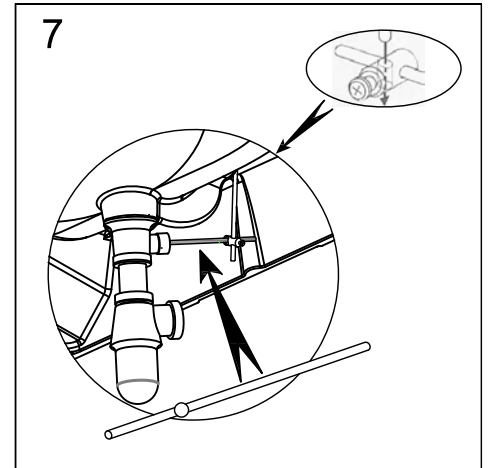
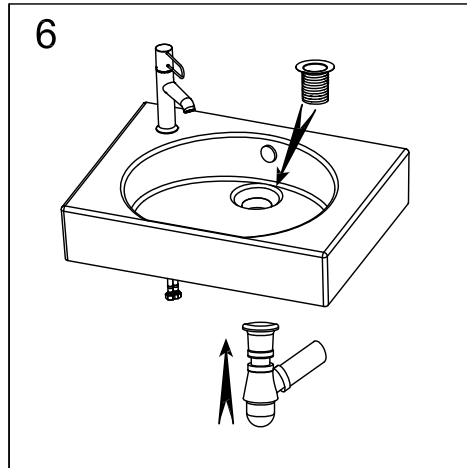
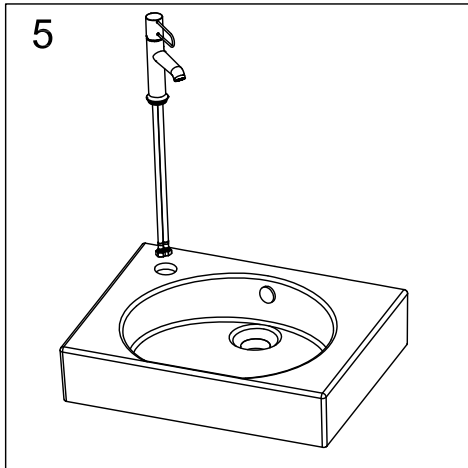

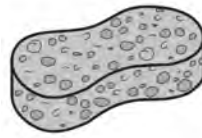

EGO112-55 / EGO112-56

1	E4061-CP	Overflow cover / Cache trop-plein chromé
2	E5510-NF	Extension for drain / Rallonge de bonde

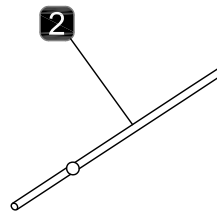
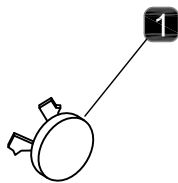

EGN112 / EGP112

1	E4061-CP	Overflow cover / Cache trop-plein chromé
---	----------	--

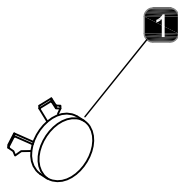

Thank you for choosing Kohler company

Your product reflects the true passion for design, craftsmanship, artistry and innovation the company stand for. We are confident its dependabilité and beauty will surpass your highest expectations, satisfying you for years to come.

Merci d'avoir choisi la marque Jacob Delafon

Votre produit est le fruit de notre savoir-faire et de notre passion pour le design et l'innovation. Nous sommes convaincus qu'il vous apportera toute satisfaction pour les années à venir.

Gracias por elegir los productos Jacob Delafon

Su producto refleja la verdadera por el diseño, la mano de obra, la artesanía y la innovación. Estamos seguros que su confiabilidad y belleza excederá sus más altas expectativas, dándole satisfacción por años.

Благодарим Вас за выбор бренда Jacob Delafon

Данный продукт отражает истинную страсть к дизайну, мастерству, стилю и инновациям, которые являются основными преимуществами нашей компании. Мы уверены, что его надежность и функциональность превзойдет все Ваши ожидания, не оставляя равнодушными долгие годы.

شكرا على اختيار مجموعة كولر

منتجكم هذا هو نتيجة لخبرتنا وحماسنا للتصميم والابتكار. نحن واثقون من أنه سيجلب لكم كل الرضى للسنوات القادمة

感谢您选择科勒公司

您的产品将彰显对设计、工艺、艺术和创新的热情，而这正是我们的代名词。我们相信，其可靠的性能和精美的外观将超越您最高的期望，在未来持续不断满足您的需求。

**Kohler UK**

Cromwell Road
Cheltenham
Gloucestershire GL52 5EP
Tel. +44 (0) 870 850 5551
www.kohler.co.uk

**Kohler Europe / Jacob Delafon France**

3, rue de Brennus
93631 La Plaine Saint Denis
Cedex
Tel. +33 (0) 1 49 17 37 37
www.jacobdelafon.fr

**Kohler Deutschland**

Holtgrade 30
45739 Oer-Erkenschwick
Tel. +49 (0) 2368 9187 87
www.kohlerco.de

**Kohler / Jacob Delafon España**

Ctra. de Logrono km. 17
50629 Sobradiel
Zaragoza
Tel. + 34 902 46 46 86
www.jacobdelafon.es

**Kohler Middle East**

Al Thuraya Tower II, 9th Floor,
Office 905
P.O. Box 500431
DIC, Dubai, UAE
Tel. + 971-4-3624650
www.me.kohler.com

**Kohler / Jacob Delafon Maroc**

207 Bd Anfa & rue
Beaumarchais
Casablanca
Tel. +212 2 295 9740
www.jacobdelafon.ma

**Kohler Africa (Pty) Ltd**

Coachmans' Crossing Office Park
Block C, Unit 2, First Floor
4 Brian Street
Lyme Park
Sandton
2060 Johannesburg
Tel. +49 (0) 2368 9187 87

**Kohler Rus**

121059 Moscow
1st Borodinskaya 2a, office 147
Tel (495) 783-52-23
www.jacobdelafon.ru

**Kohler China Investment Co., Ltd.**

No. 158, Jiang Chang San Road.
Zhabei District, Shanghai, PRC
PC: 200436
科勒（中国）投资有限公司
中国，上海市，闸北区，江场三路158号，200436

ООО «КОЛЕР РУС»,

121059, г. Москва, ул.1-я Бородинская, 2а,
тел: (495) 783-52-23

**«КОЛЕР РУС» ЖШҚ**

Ресей, 121059, Мәскеу қ., 1-ші Бородинская көш., 2а
тел: (495) 783-52-23