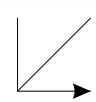
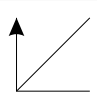
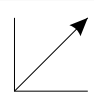

ASTI. Стол 3 / table 3

Код ТН ВЭД ЕАЭС

9403 60 100 1
9403 90 300 0

отрезать
и приклеить

		
1100	750	506

12АСБЗ / 4114

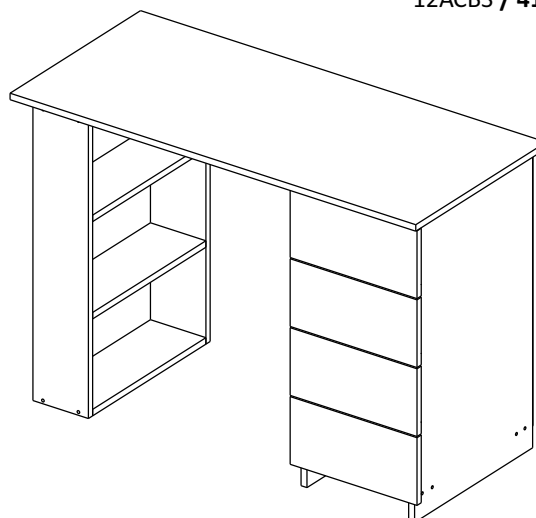
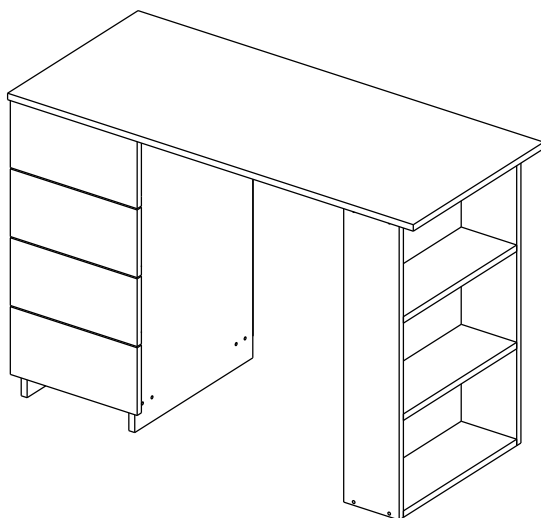

Комплектовочная ведомость / Set package sheet

Упак/ Package	Наименование	Description	Цвет детали/ Décor	Размер / Size, mm	Кол-во/ Quantity	№
1	Крыша	Top	White	1100x506	1	4
	Боковина правая	Side right		734x446	1	3
	Вязка	Connecting element		275x90	1	7
	Панель	Drawer panel		343x167	2	11
	Направл 400 мм		-	-	4	-
	Боковина левая	Side left	White	734x446	1	2
	Вязка	Connecting element		275x90	1	7
	Панель	Drawer panel		343x167	2	11
	Фурнитура	Furniture/Cabinetry hardware	-	-	-	-
	Боковина	Side	White	734x152	1	1
	Вязка наружн	Connecting element external		428x152	2	6
	Боковина ящ прав	Side drawers right		100x400	4	9
	Деталь ящика	Side drawers		100x217	2	10
	Боковина	Side		734x152	1	1
	Вязка внутр	Connecting element internal		428x152	2	5
	Боковина ящ лев	Side drawers left		100x400	4	8
	Деталь ящика	Side drawers		100x217	2	10
	ДВП	Back element		682x303	1	13
	ДВП	Back element		407x249	4	12

(PL) Instrukcja montażu

(CZ) Návod k montáži

(D) Montageanleitung

(GB) Assembly instruction

(F) Model d'emploi

(HU) Szerelési útmutató

(I) Istruzione di montaggio

(NL) Handleiding voor de montage

(RU) Инструкция по монтажу

(RO) Instrucțiuni de montare

(SK) Návod k montáži

(TR) Montaj talimatı

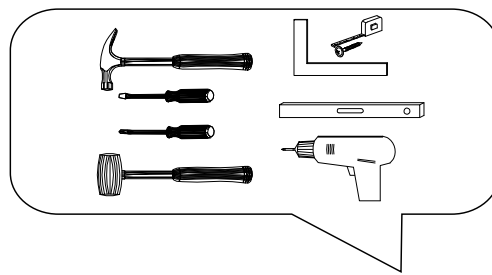



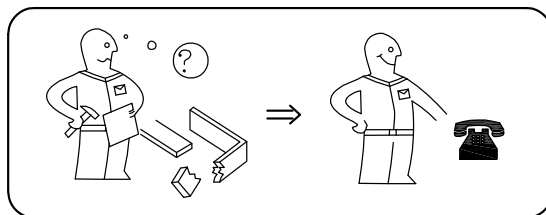
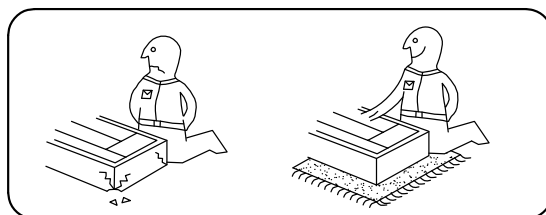



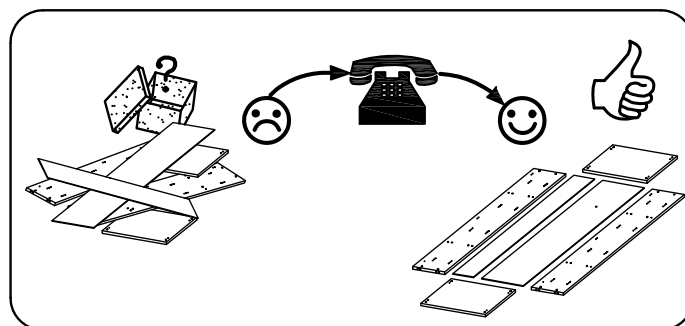
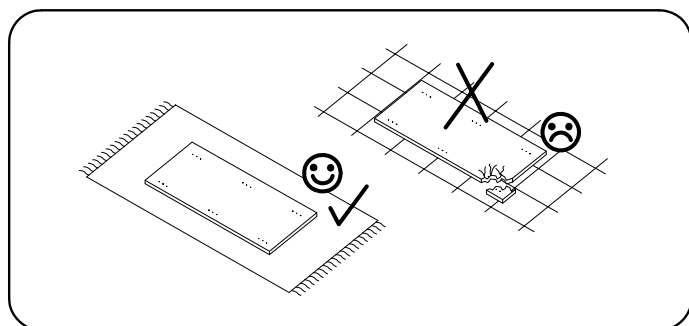
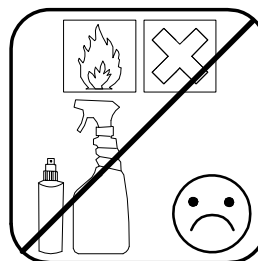
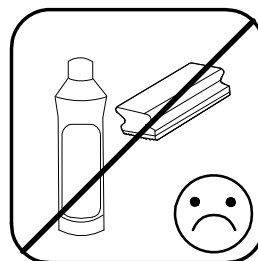
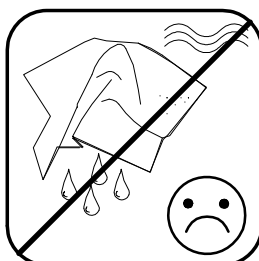
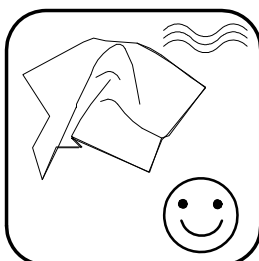
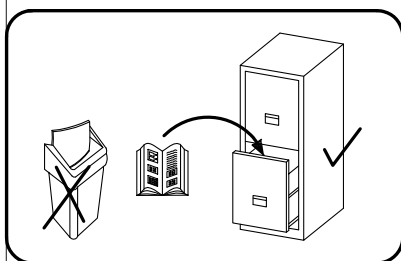

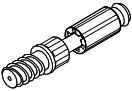
⚠ Uwaga • Upozornění • Achtung • Attention • Caution • Figyelem • Attenzione • Opgelet • Внимание • Atenție • Upozornenie • Dikkat ⚠	
PL	Czyszczenie należy wykonać wyłącznie za pomocą ściereczki lub lekko nawilżonego ręcznika. Nie stosować środków czyszczących do szorowania.
CZ	Čistění je nutné vykonávat výhradně pomocí utěrky nebo lehce navlhčeného ručníku. Nepoužívejte čisticí prostředky obsahující abrazivní částice.
D	Bitte nur mit einem Staubtuch oder leicht feuchtem Lappen reinigen. Keine scheuernden Putzmittel verwenden.
GB	Please only clean with a duster or a damp cloth. Do not use any abrasive cleaners.
F	Le nettoyage se fait uniquement à l'aide d'un torchon ou d'une serviette légèrement mouillée.
HU	A tisztítás kizárólag törölrőruha vagy enyhén nedvesített törölköző segítségével végezhető. Súroló hatású tisztítószerket nem szabad használni.
I	Pulire esclusivamente con un panno o un asciugamano umido.
NL	Reinig alleen met een stofdoek of een lichtjes vochtige doek. Gebruik geen schurende poetsmiddelen.
RU	Очищайте от пыли тряпкой или слегка влажной ветошью. Не допускается применение чистящих средств, не предназначенных для ухода за мебелью.
RO	Curățarea trebuie efectuată numai cu o cârpă sau cu un prosop ușor umezit. Nu utilizați agenți de curățare abrazivi.
SK	Čistení je nutné vykonávať výhradne pomocí utierky alebo ľahko zvlhnutým ručníkom. Nepoužívajte čistiace prostriedky obsahujúci abrazívni častice.
TR	Lütfen sadece bir toz bezilye veya hafif nemli yumuşak bir bezle siliniz. Aşındırıcı temizlik malzemeleri kullanmayınız.

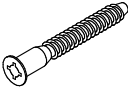

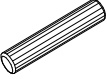
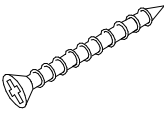
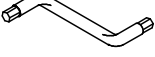
**Karta serwisowa • Servisní list • Service Karte • Service card • Carte de service • Szervizkártya
Scheda di servizio • Service kaart • Сервисная карта • Fisa service • Servisný list • Servis karti**

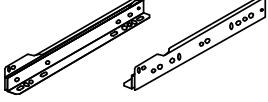
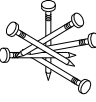

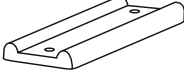
1		2		5	7x50	6	6,3x10,5	7	8x30
									
12 x		12 x		24 x		16 x		12 x	
14	3,5x30	15		18	3,5x15	24	400 mm	48	2x20
									
2 x		1 x		40 x		4 x		30 x	
72		73		76					
									
12 x		24 x		6 x					

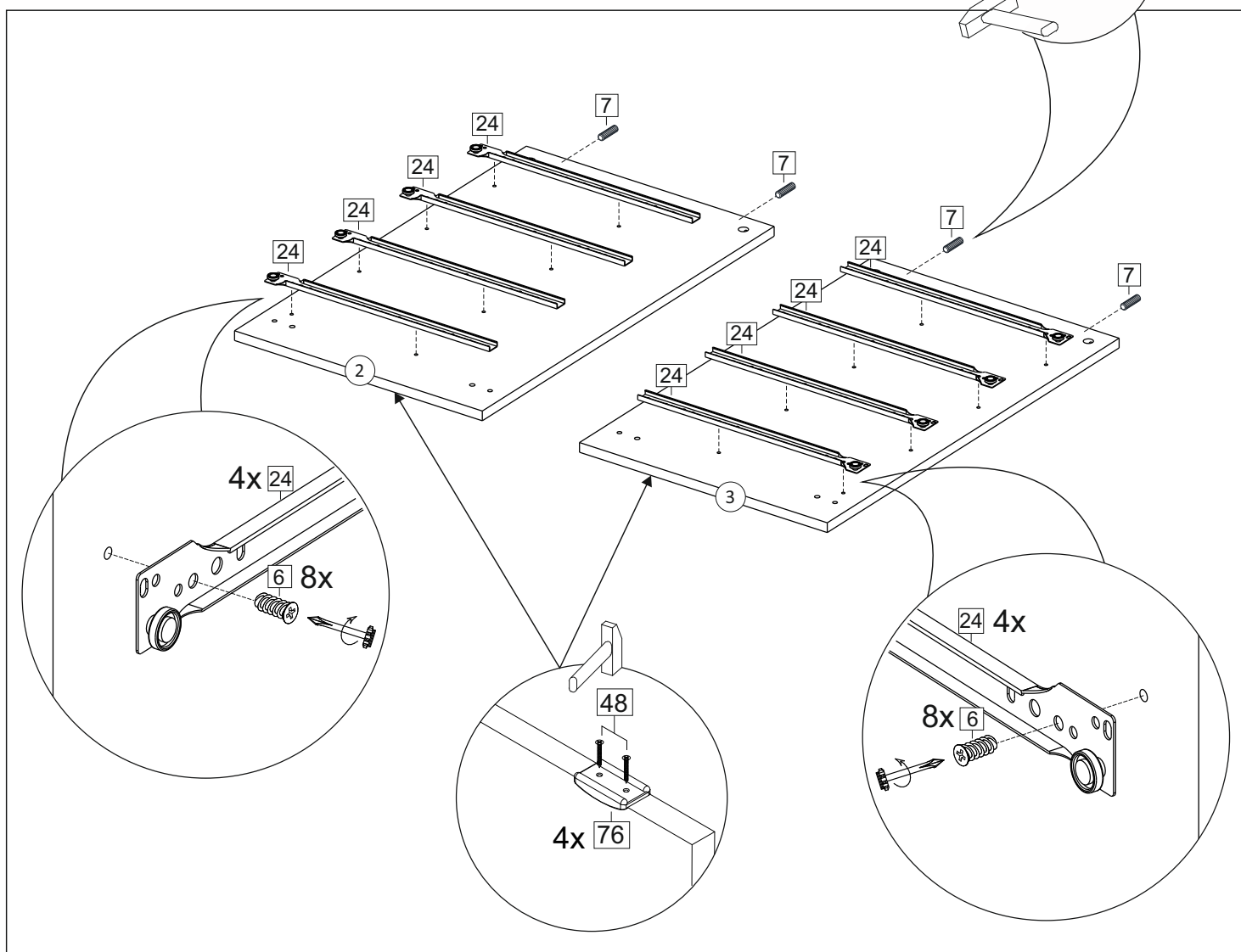

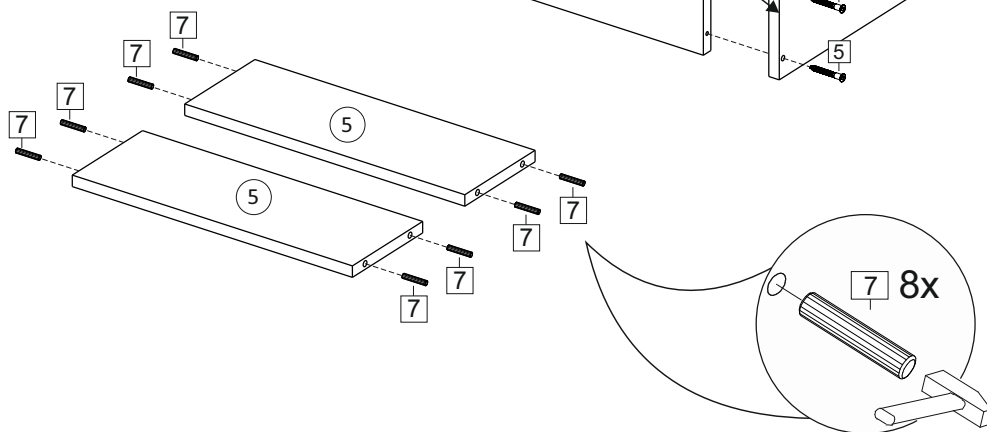
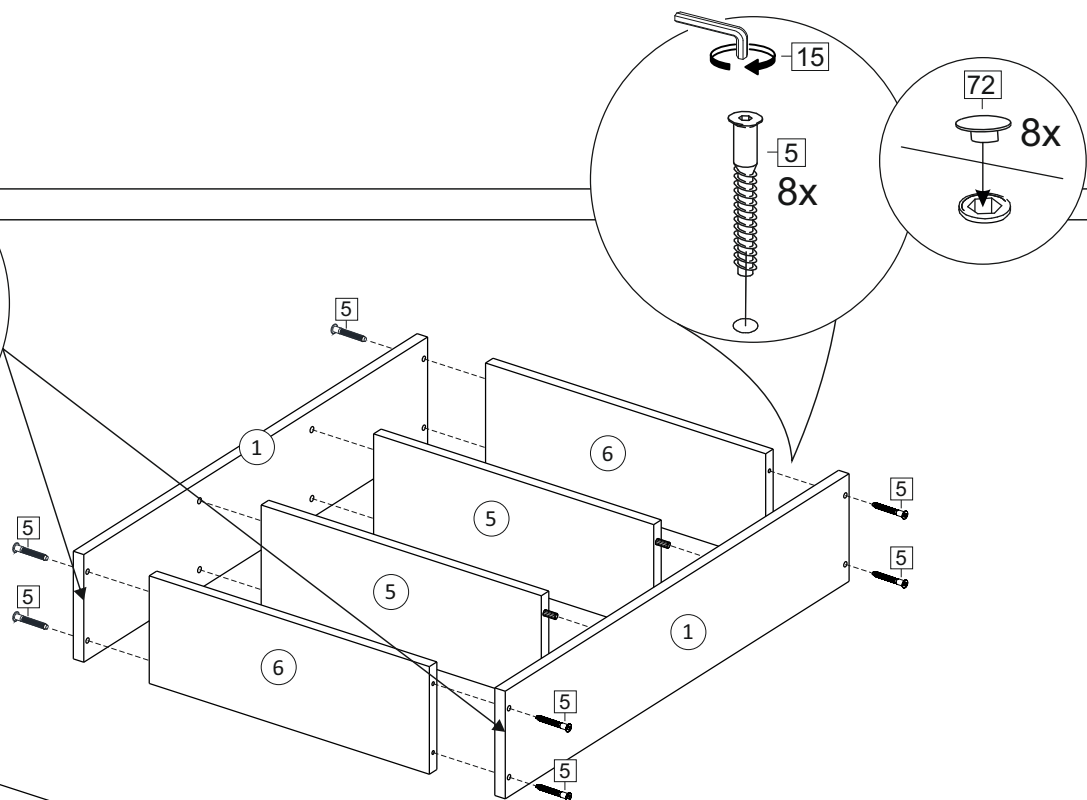
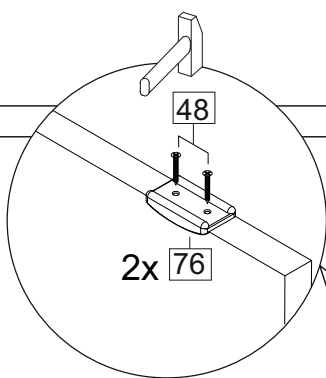
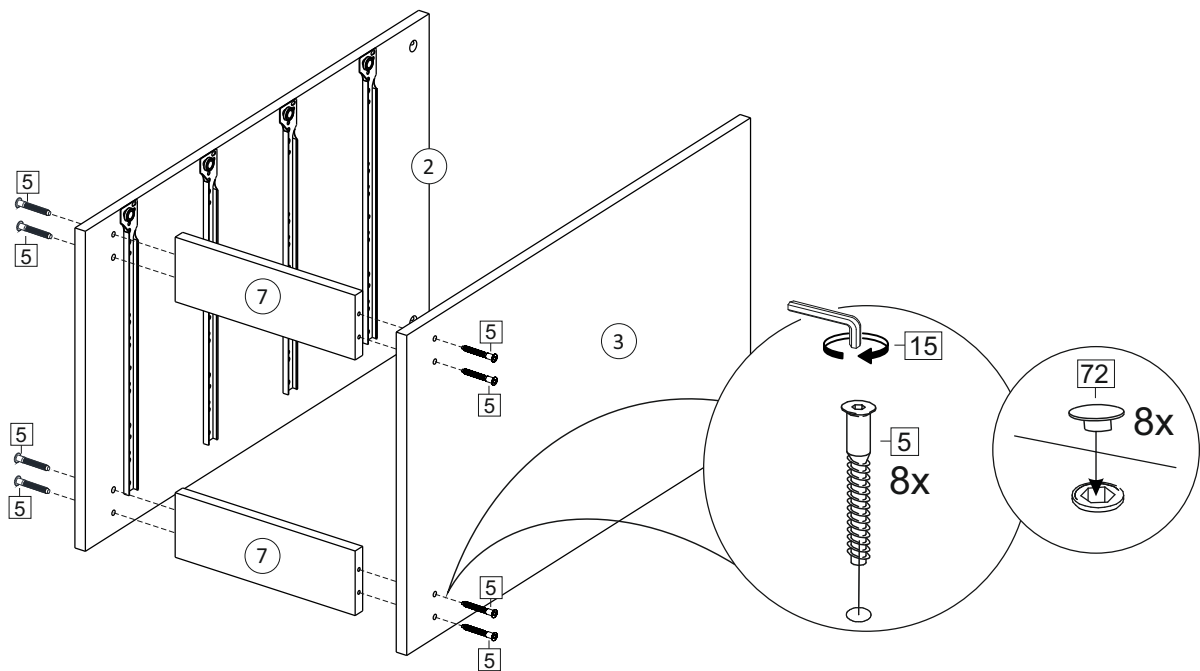

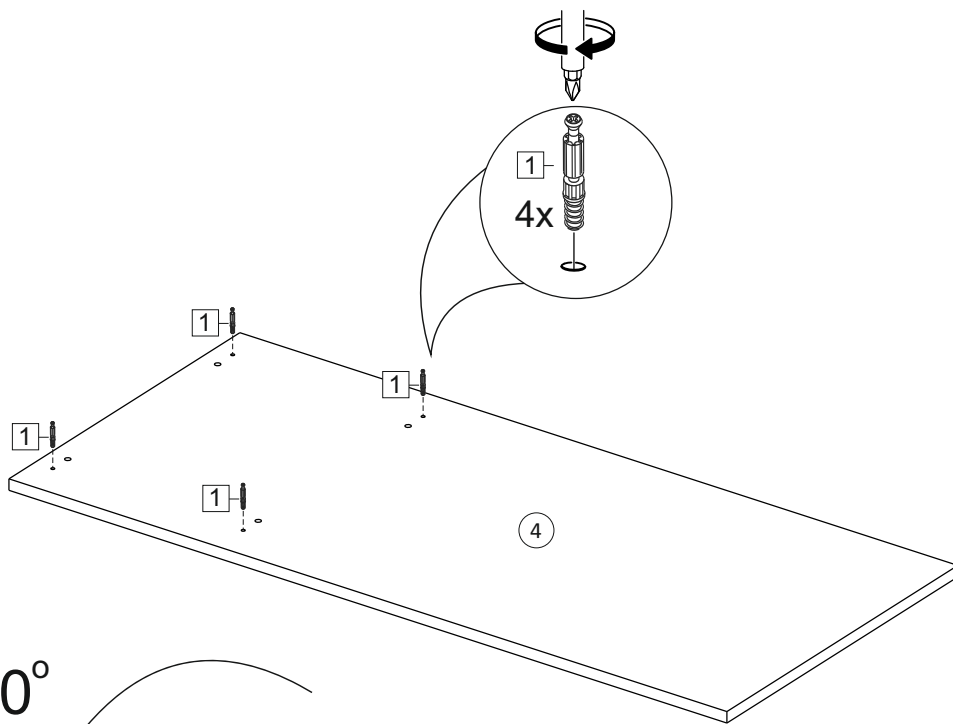

180°

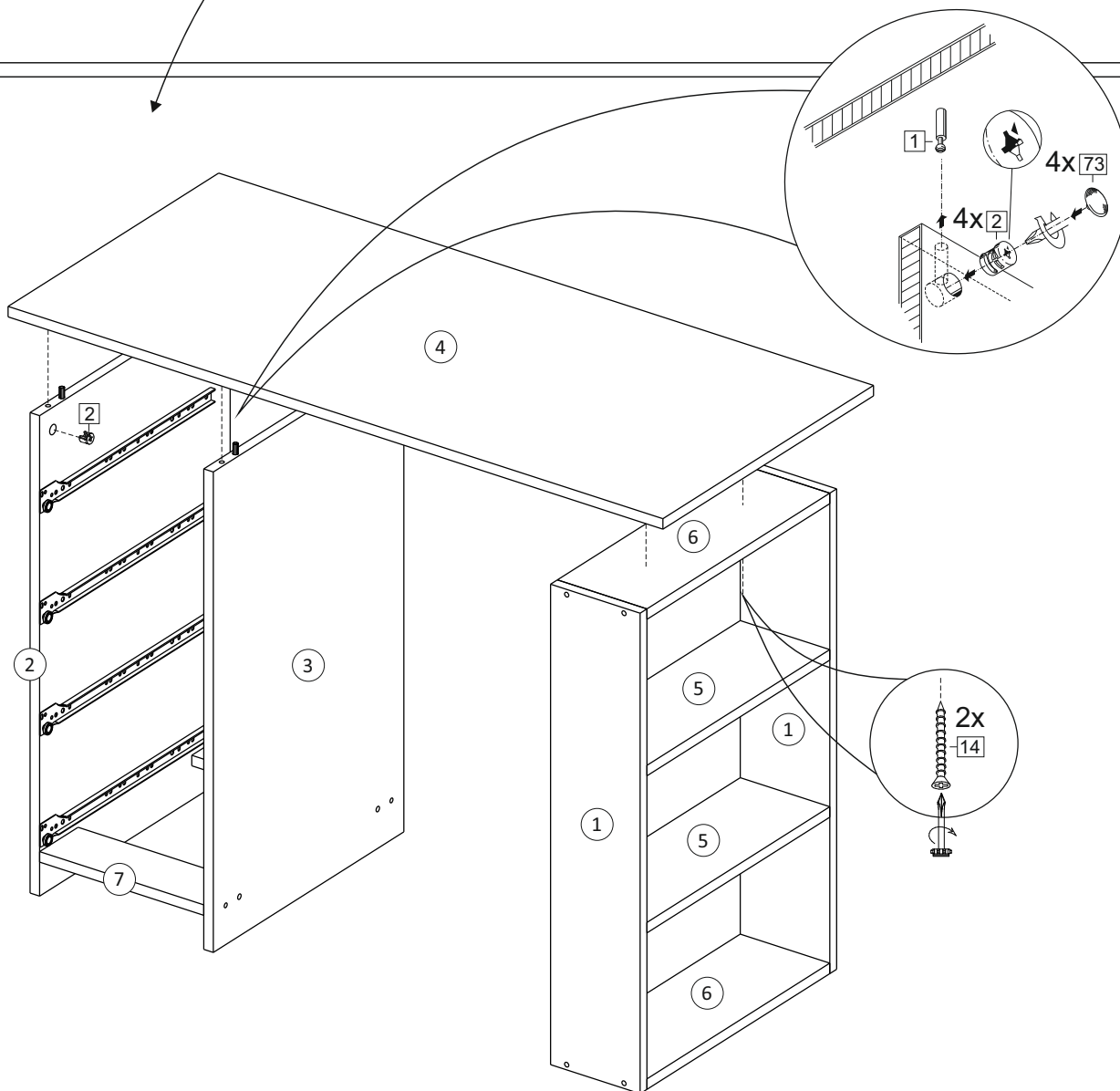

6

