

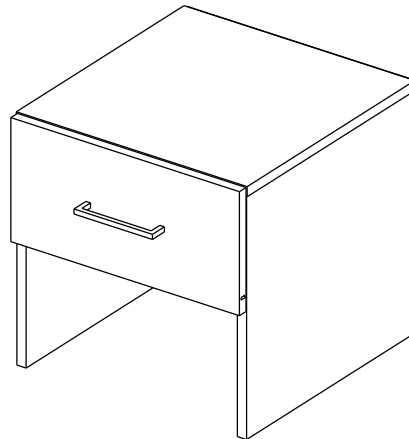



Тумба / bedside table VICTOR

Код ТН ВЭД ЕАЭС

9403 60 100 1
9403 90 300 0

отрезать
и приклеить









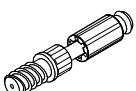

		
400	400	406

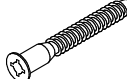
36ТСС / 3415
36ТСБ / 3414
36ТББ / 3412
36ТБЧ / 3413

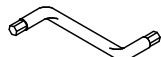
Комплектовочная ведомость / Set package sheet

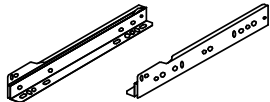
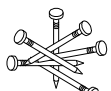
Упак/ Package	Наименование	Description	Цвет детали/ Décor				Размер / Size, mm	Кол-во/ Quantity	№
			Sonoma	Sonoma- White	White	White- Concrete			
1	Крыша	Top					400x406	1	3
	Фурнитура	Furniture/Cabinetry hardware	-	-	-	-	-	1	-
	Вязка	Connecting element	Sonoma	Sonoma	White	White	366x406	1	4
	Деталь ящика	Side drawers					100x400	2	5
	Деталь ящика	Side drawers					100x308	1	6
	Панель ящика	Drawer panel					396x196	1	7
	ДВП	Back element					340x406	1	8
	ДВП	Back element					196x396	1	9
	Боковина левая	Side left					384x406	1	1
	Боковина правая	Side right					384x406	1	2

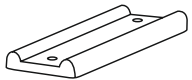
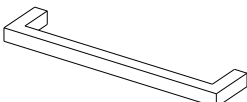
1		2		5	7x50	6	6,3x10,5	15	
									
10 x		10 x		2 x		4 x		1 x	
18	3,5x15	24	400 mm	48	2x20	72		73	
									
15 x		1 x		20 x		2 x		10 x	
76		126	C42 128 mm						
									
4 x		1 x							

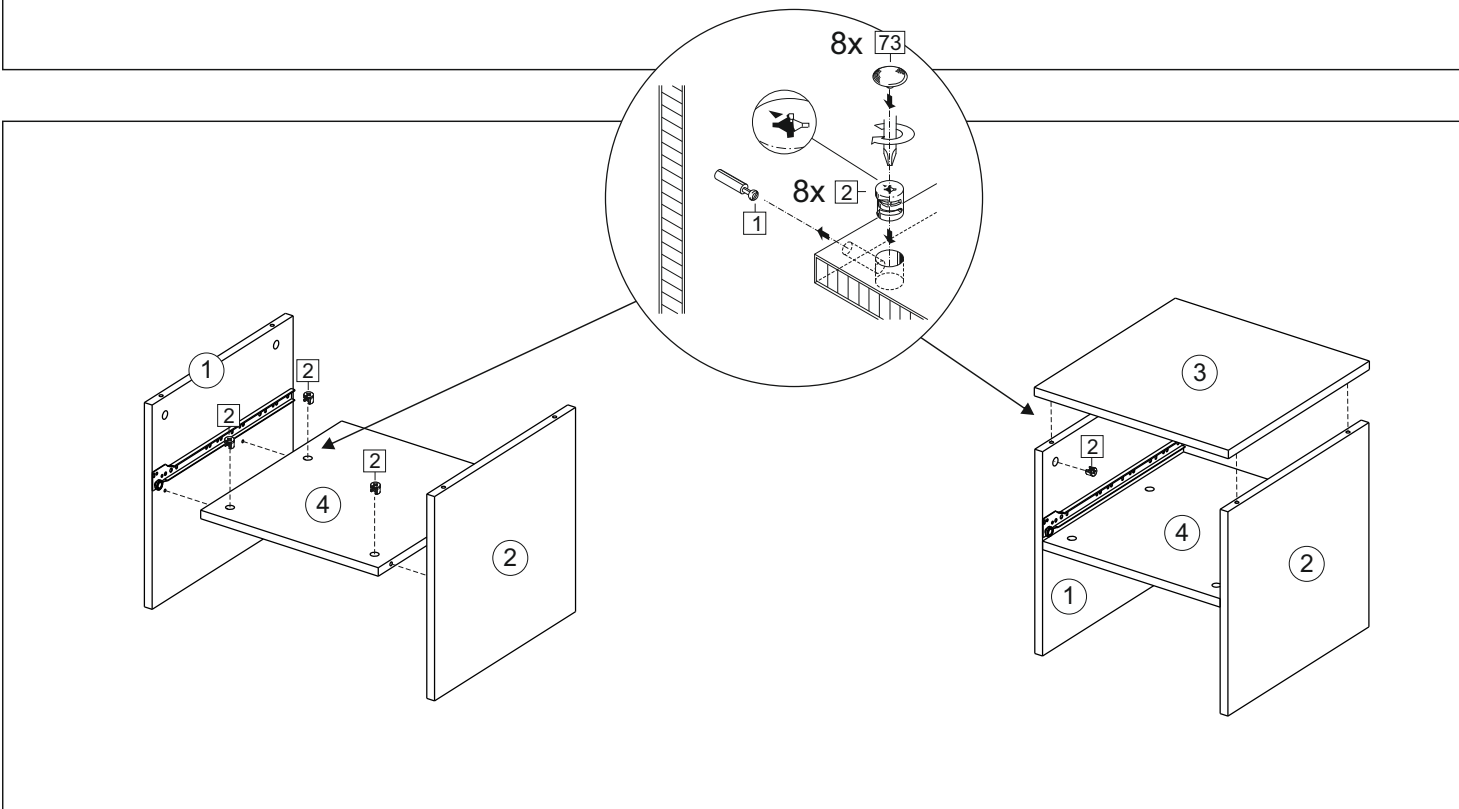
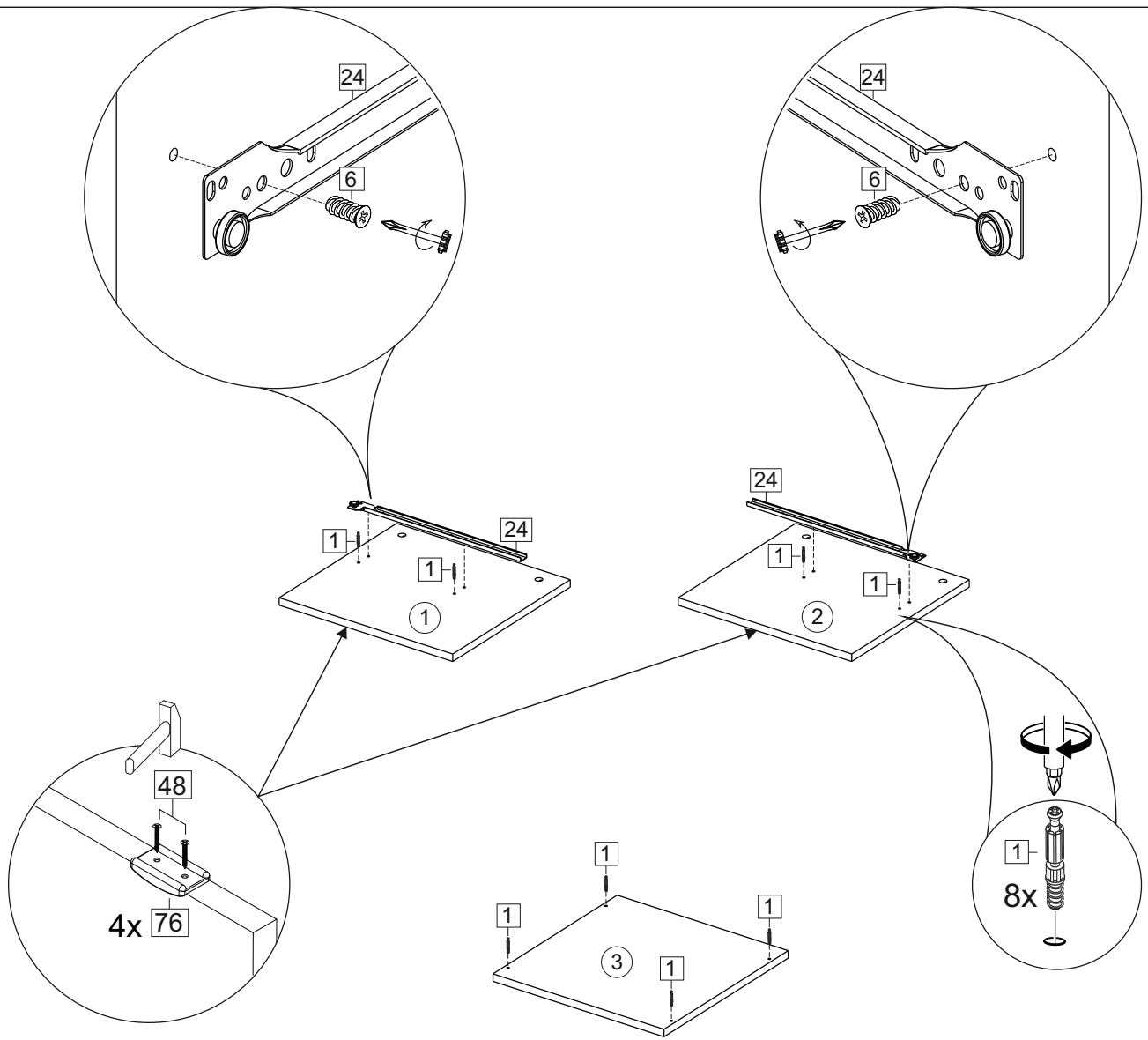

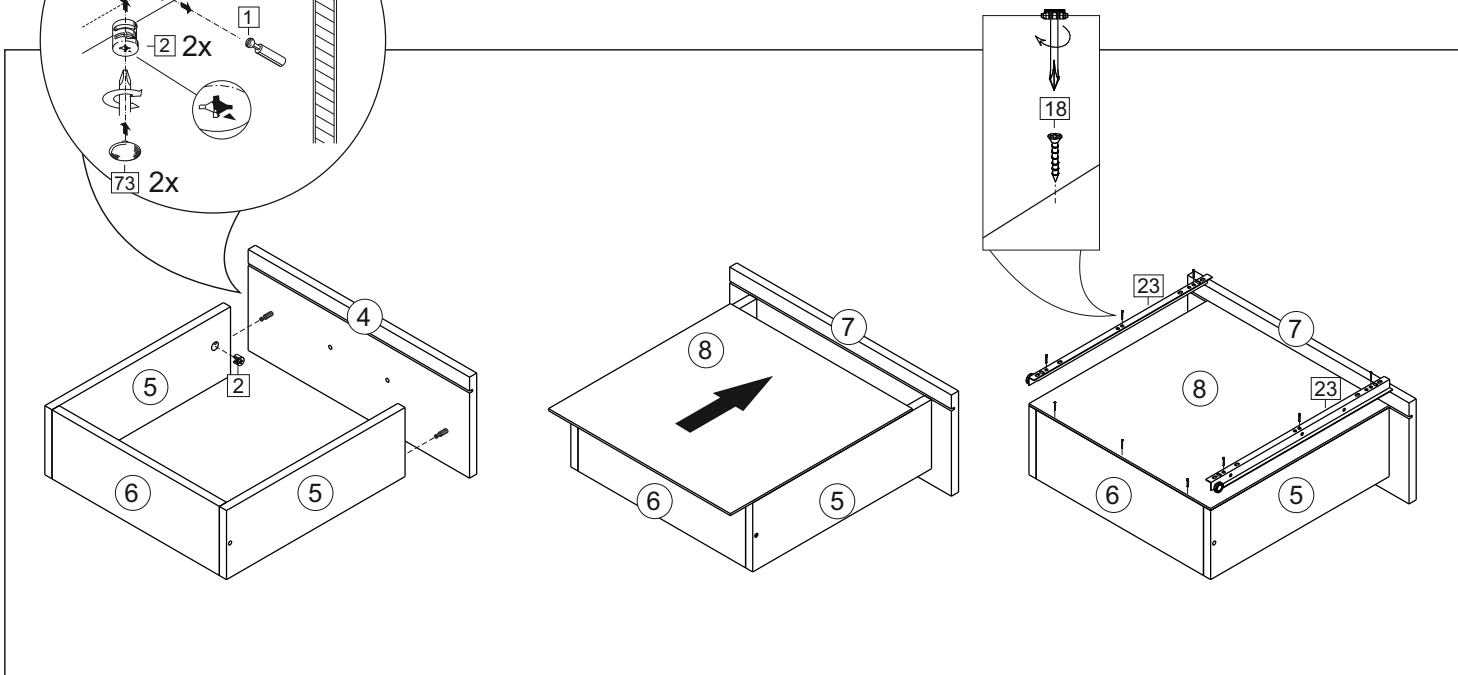
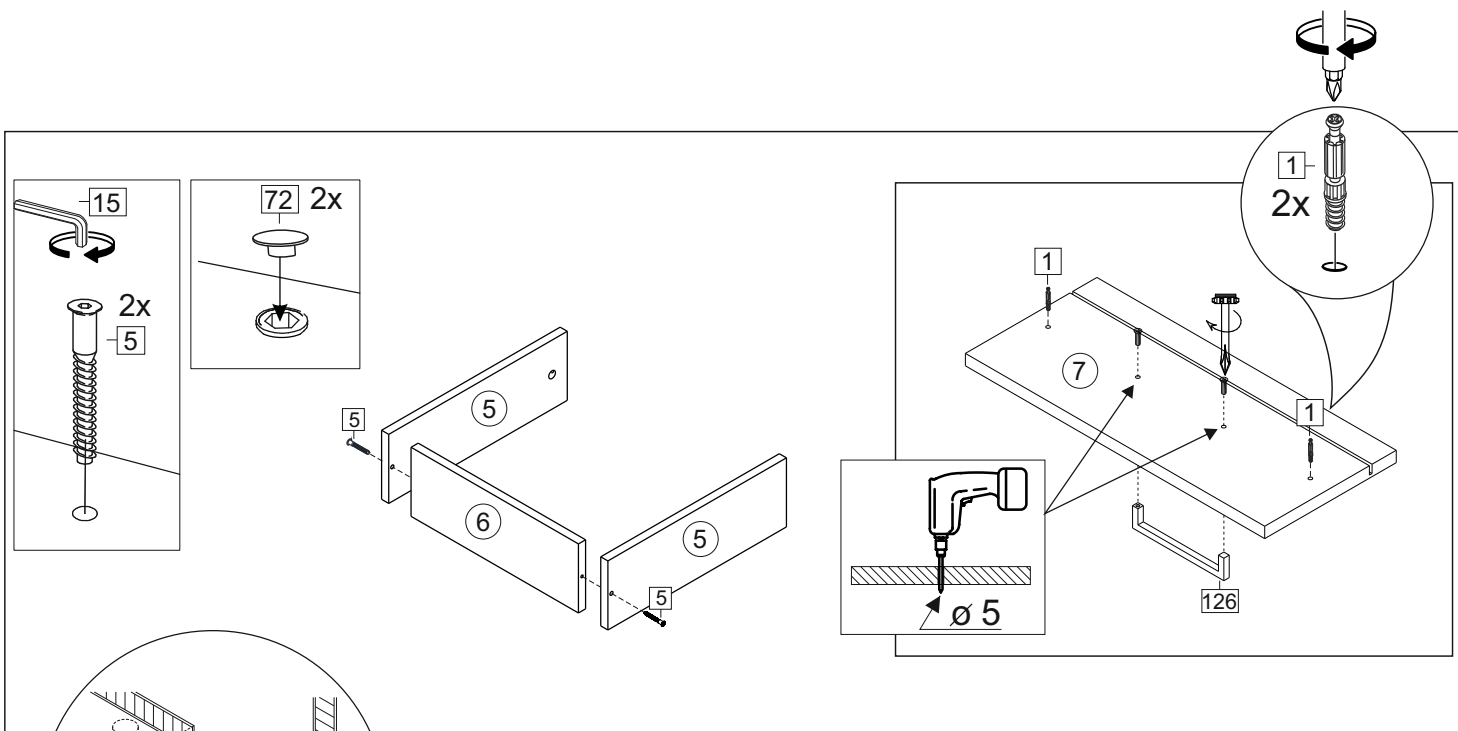
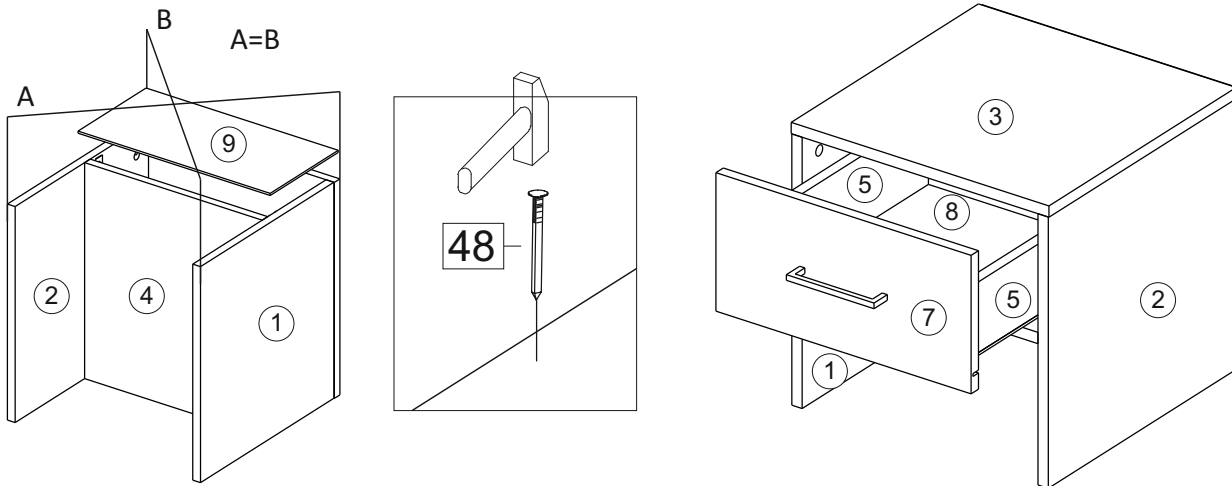

(PL) Instrukcja montażu

(CZ) Návod k montáži

(D) Montageanleitung

(GB) Assembly instruction

(F) Model d'emploi

(HU) Szerelési útmutató

(I) Istruzione di montaggio

(NL) Handleiding voor de montage

(RU) Инструкция по монтажу

(RO) Instrucțiuni de montare

(SK) Návod k montáži

(TR) Montaj talimatı



⚠ Uwaga • Upozornění • Achtung • Attention • Caution • Figyelem • Attenzione • Opgelet • Внимание • Atenție • Upozornenie • Dikkat ⚠

PL	Czyszczenie należy wykonać wyłącznie za pomocą ściereczki lub lekko nawilżonego ręcznika. Nie stosować środków czyszczących do szorowania.
CZ	Čistění je nutné vykonávat výhradně pomocí utěrky nebo lehce navlhčeného ručníku. Nepoužívejte čisticí prostředky obsahující abrazivní částice.
D	Bitte nur mit einem Staubtuch oder leicht feuchtem Lappen reinigen. Keine scheuernden Putzmittel verwenden.
GB	Please only clean with a duster or a damp cloth. Do not use any abrasive cleaners.
F	Le nettoyage se fait uniquement à l'aide d'un torchon ou d'une serviette légèrement mouillée.
HU	A tisztítás kizárólag törölrőruha vagy enyhén nedvesített törölköző segítségével végezhető. Súroló hatású tisztítószerket nem szabad használni.
I	Pulire esclusivamente con un panno o un asciugamano umido.
NL	Reinig alleen met een stofdoek of een lichtjes vochtige doek. Gebruik geen schurende poetsmiddelen.
RU	Очищайте от пыли тряпкой или слегка влажной ветошью. Не допускается применение чистящих средств, не предназначенных для ухода за мебелью.
RO	Curățarea trebuie efectuată numai cu o cârpă sau cu un prosop ușor umezit. Nu utilizați agenți de curățare abrazivi.
SK	Čistení je nutné vykonávať výhradne pomocí utierky alebo ľahko zvlhnutým ručníkom. Nepoužívajte čistiaci prostriedky obsahujúci abrazívni častice.
TR	Lütfen sadece bir toz bezilye veya hafif nemli yumuşak bir bezle siliniz. Aşındırıcı temizlik malzemeleri kullanmayınız.



Karta serwisowa • Servisní list • Service Karte • Service card • Carte de service • Szervizkártya • Scheda di servizio • Service kaart • Сервисная карта • Fisa service • Servisný list • Servis karti

