

## Тумба МИЛАНА / Bedside table MILANA

Код ТН ВЭД ЕАЭС

9403 60 100 1  
9403 90 300 0

отрезать  
и приклеить

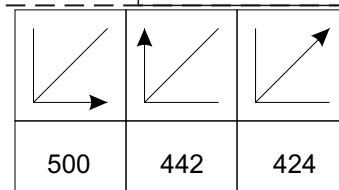

32ТМК2509

32ТМФ2510

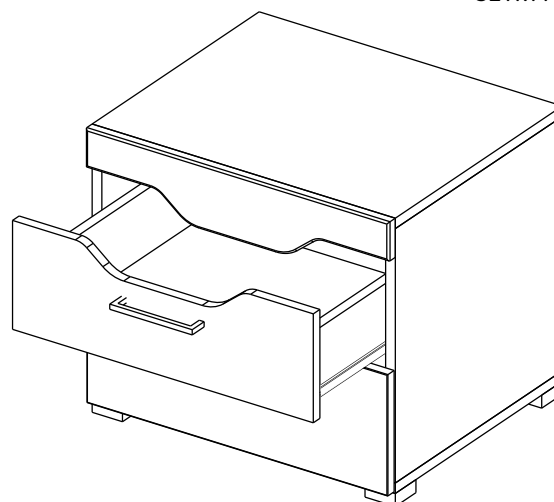
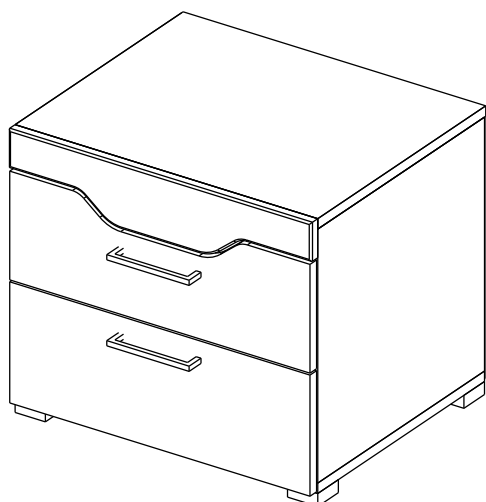

### Комплектовочная ведомость/Set package sheet







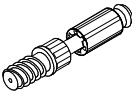

Упак/ Package	Наименование	Description	Цвет детали/ Décor	Размер / Size, mm	Кол-во/ Quantity	№
1	Фурнитура	Furniture/Cabinetry hardware	-	-	-	-
2	Боковина левая	Side left	White	390x405	1	1
	Боковина правая	Side right	White	390x405	1	2
	Крыша нижняя	Top lower	White	500x405	1	4
	Деталь ящика	Side drawers	White	100x400	4	5
	Деталь ящика	Side drawers	White	100x409	2	6
	ДВП	Back element	White	407x441	2	10
	ДВП	Back element	White	404x496	1	11

Продается отдельно/Sold separately

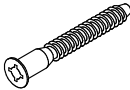
1	Панель (вырез)	Drawer panel (cut)	White	167x496	1	8
	Панель	Drawer panel	White	186x496	1	9
	Крыша МДФ верхняя	Top MDF upper	Pine grand	500x408	1	3
	Планка	Plank	Pine grand	500x100	1	7

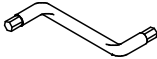
White - Белый

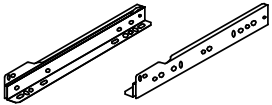
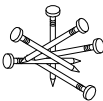
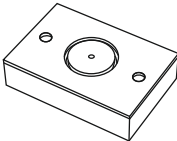
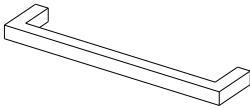
Pine grand - Сосна гранд

1		2		5	7x50	6	6,3x10,5	15	
									
10 x		10 x		8 x		8 x		1 x	
18	3,5x15	24	400 mm	48	2x20	62	80x50x20 mm	126	C42 128 mm
									
32 x		2 x		20 x		4 x		2 x	
72	Белый/White	73	Белый/White						
									
4 x		8 x							

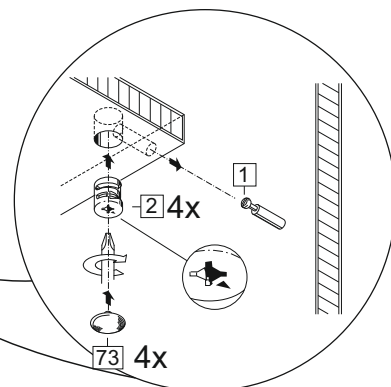
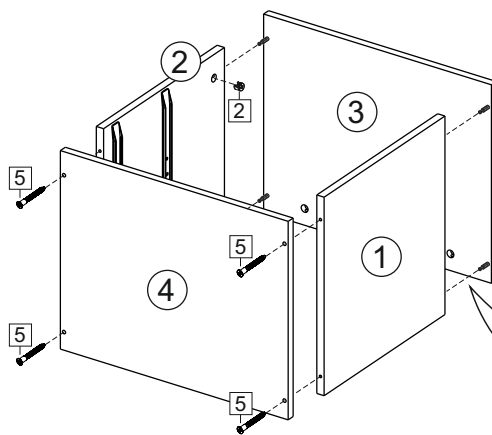
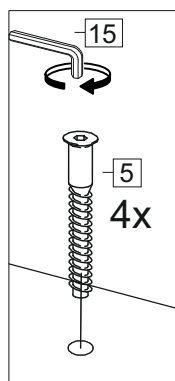
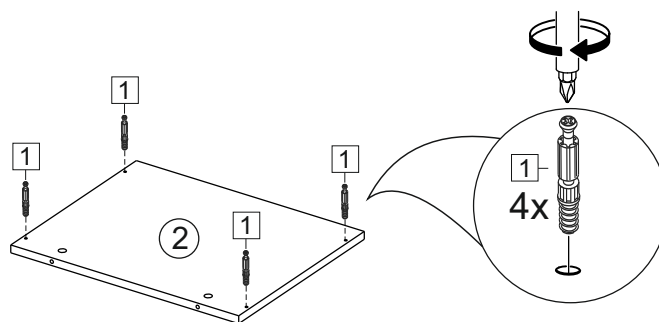
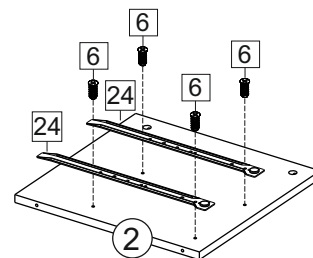
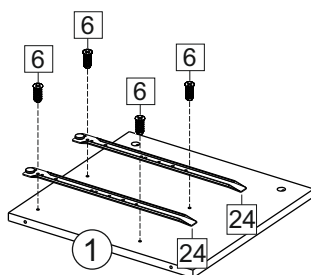
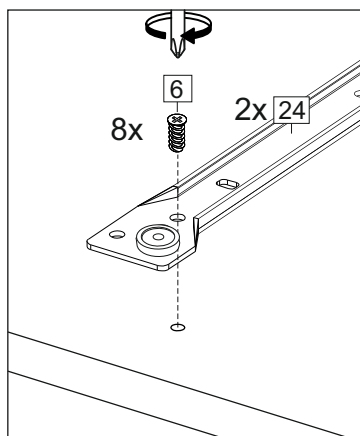

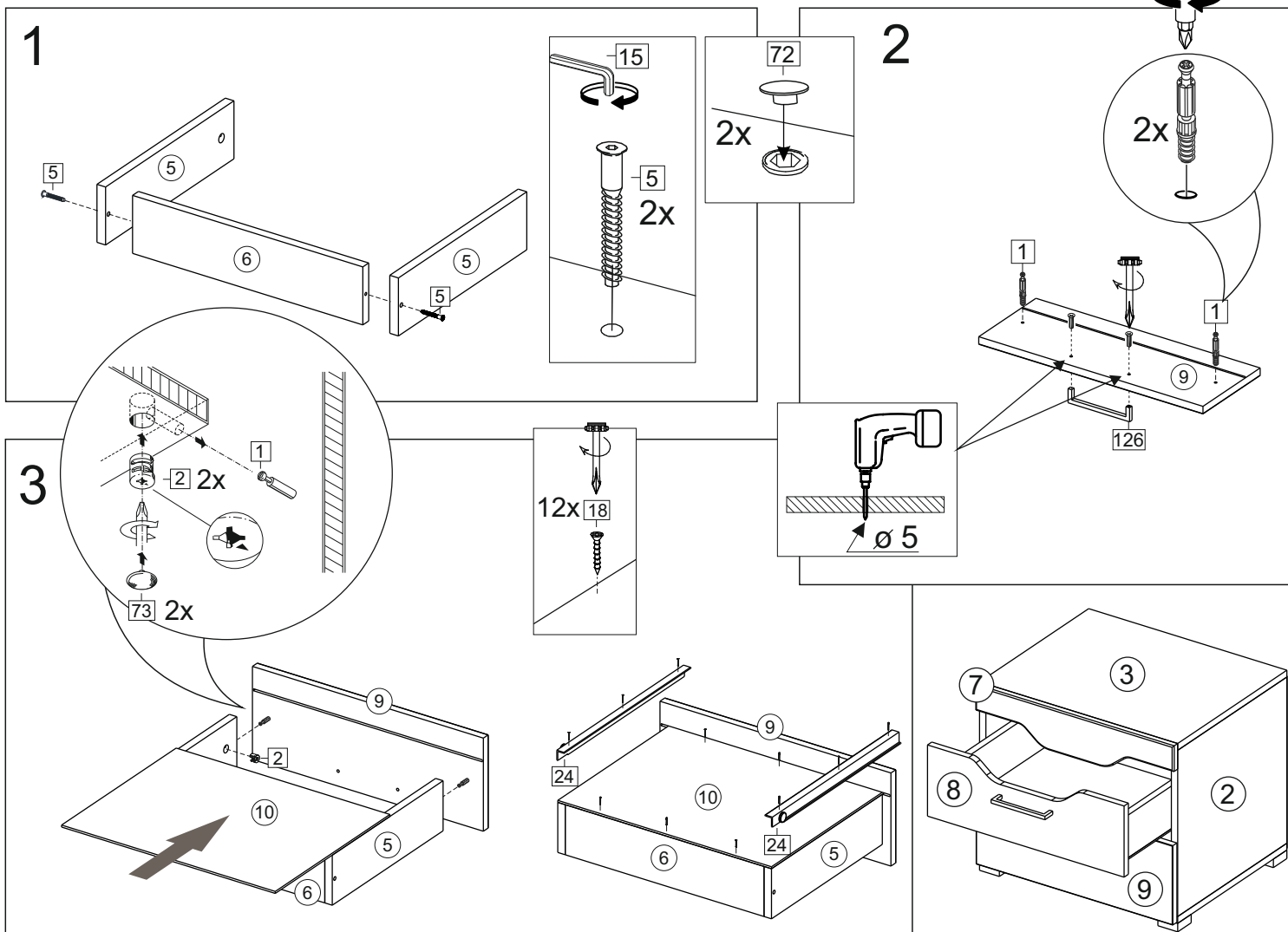
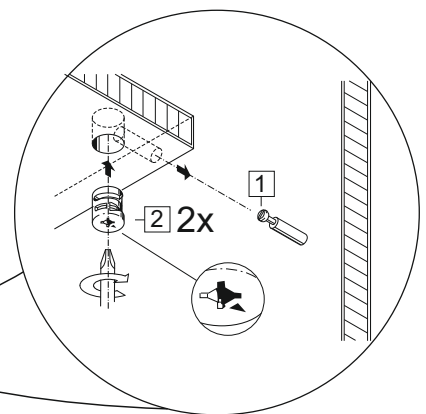
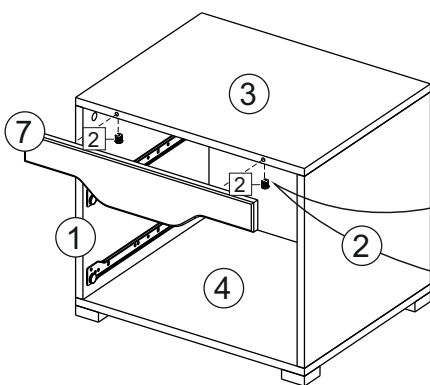
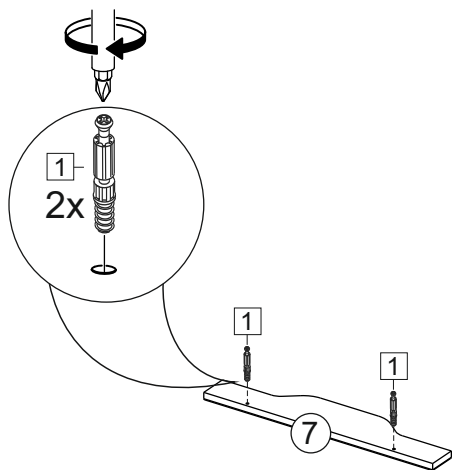
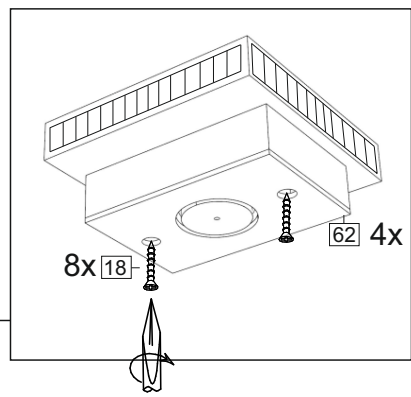
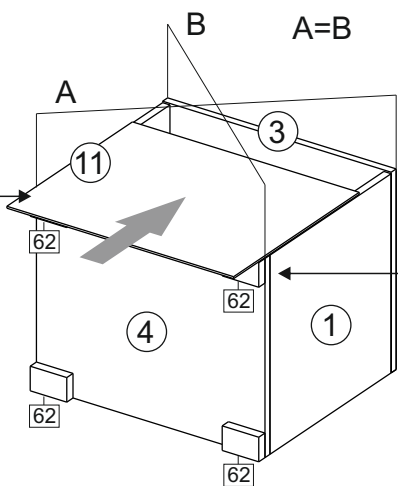
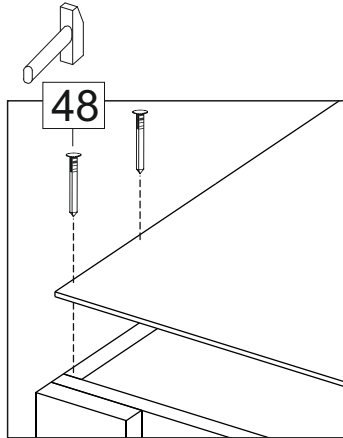

(PL) Instrukcja montażu

(CZ) Návod k montáži

(D) Montageanleitung

(GB) Assembly instruction

(F) Model d'emploi

(HU) Szerelési útmutató

(I) Istruzione di montaggio

(NL) Handleiding voor de montage

(RU) Инструкция по монтажу

(RO) Instrucțiuni de montare

(SK) Návod k montáži

(TR) Montaj talimatı



⚠ Uwaga • Upozornění • Achtung • Attention • Caution • Figyelem • Attenzione • Opgelet • Внимание • Atenție • Upozornenie • Dikkat ⚠	
PL	Czyszczenie należy wykonać wyłącznie za pomocą ściereczki lub lekko nawilżonego ręcznika. Nie stosować środków czyszczących do szorowania.
CZ	Čistění je nutné vykonávat výhradně pomocí utěrky nebo lehce navlhčeného ručníku. Nepoužívejte čisticí prostředky obsahující abrazivní částice.
D	Bitte nur mit einem Staubtuch oder leicht feuchtem Lappen reinigen. Keine scheuernden Putzmittel verwenden.
GB	Please only clean with a duster or a damp cloth. Do not use any abrasive cleaners.
F	Le nettoyage se fait uniquement à l'aide d'un torchon ou d'une serviette légèrement mouillée.
HU	A tisztítás kizárólag törölrőruha vagy enyhén nedvesített törölköző segítségével végezhető. Súroló hatású tisztítószerket nem szabad használni.
I	Pulire esclusivamente con un panno o un asciugamano umido.
NL	Reinig alleen met een stofdoek of een lichtjes vochtige doek. Gebruik geen schurende poetsmiddelen.
RU	Очищайте от пыли тряпкой или слегка влажной ветошью. Не допускается применение чистящих средств, не предназначенных для ухода за мебелью.
RO	Curățarea trebuie efectuată numai cu o cârpă sau cu un prosop ușor umezit. Nu utilizați agenți de curățare abrazivi.
SK	Čistení je nutné vykonávat výhradně pomocí utěrky nebo ľahko zvlhnutým ručníkom. Nepoužívajte čistiace prostriedky obsahujúce abrazívni častice.
TR	Lütfen sadece bir toz bezilye veya hafif nemli yumuşak bir bezle siliniz. Aşındırıcı temizlik malzemeleri kullanmayınız.



**Karta serwisowa • Servisní list • Service Karte • Service card • Carte de service • Szervizkártya  
Scheda di servizio • Service kaart • Сервисная карта • Fisa service • Servisný list • Servis karti**

