

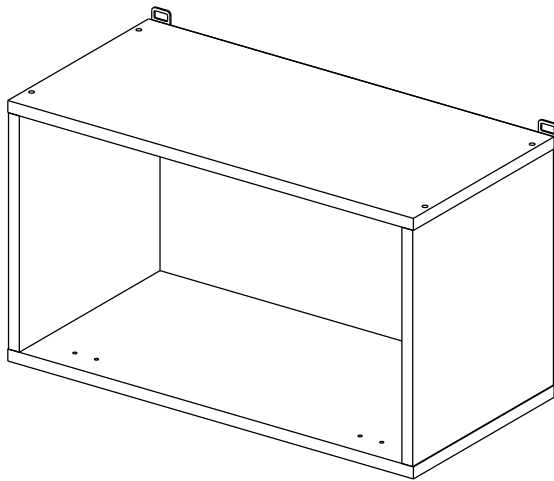



Шкаф газовка 50/60/80
Kitchen cabinet with lift door 50/60/80

Код ТН ВЭД ЕАЭС

9403 40 100 0
9403 90 300 0

отрезать
и приклеить



		
500/600/ 800	345	298

корпус
70Г50Б1611
70Г60Б1612
70Г80Б1613

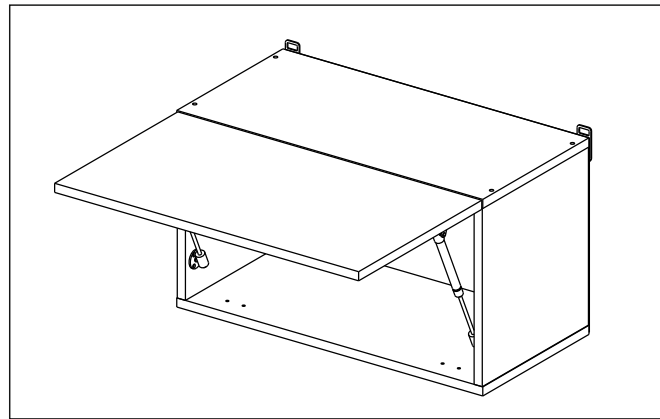

Комплектовочная ведомость / Set package sheet

Упак/ Package	Наименование	Description	Цвет детали/Décor			Размер / Size, mm			Кол-во/ Quantity	№
			-	-	-	50	60	80		
Package case	Фурнитура	Furniture/Cabinetry	-	-	-	-	-	-	1	-
	Бок	Side	Белый	White	313x294	313x294	313x294	2	1	
	Крышка	Top	Белый	White	500x294	600x294	800x294	2	2	

Продается отдельно/Sold separately

Package door/ panel	Створка	Door	см упак/look at the package		341x496	341x596	341x796	1	4
			Белый	White	341x496	341x596	341x796		
	ХДФ	Back element	Белый	White	341x496	341x596	341x796	1	3
	Ручка	Hadle	-	-	-	-	-	1	-

***Внимание!!! Attention!!! Cabinet Handles**

Europe, Polonez, Loft, Lux - C36
Princess, Kameliya - FS 186 096
Vintage - СПА5
Eva - K17

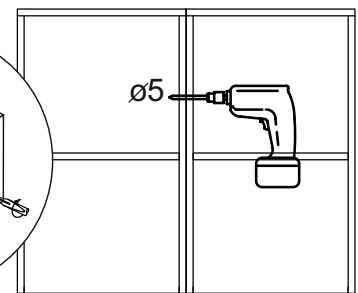
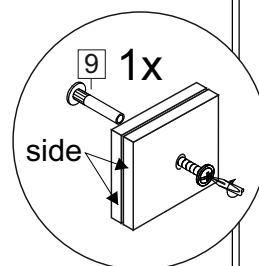

91	A	5	7*50	78	Gas-filled strut	*		53
								
2 x		8 x			500/600 - 1x 800 - 2x	1 x		2 x
3		6	6,3*10,5	18	3,5*15	10	3,5*25	48
								
2 x		4 x		500/600 - 10x 800 - 15x		8 x		20 x
72		9		15				
								
8 x		1 x		1 x				

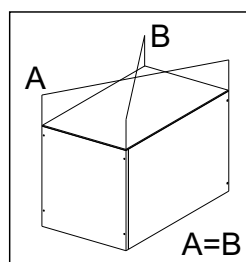
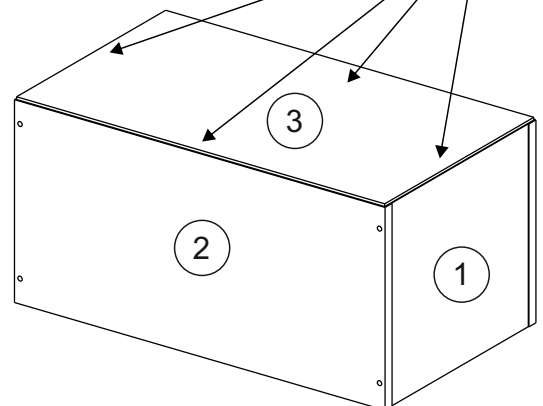
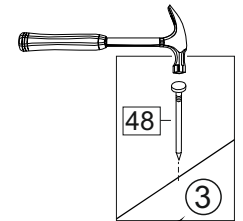
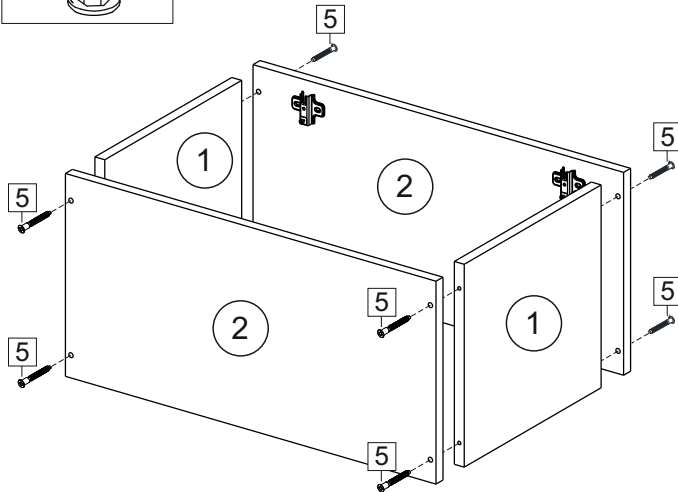
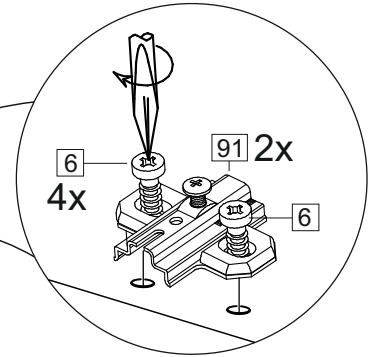
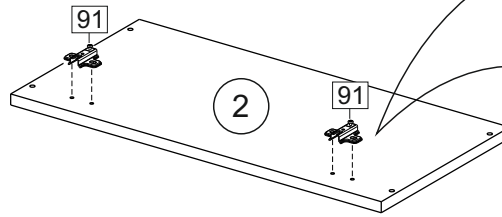

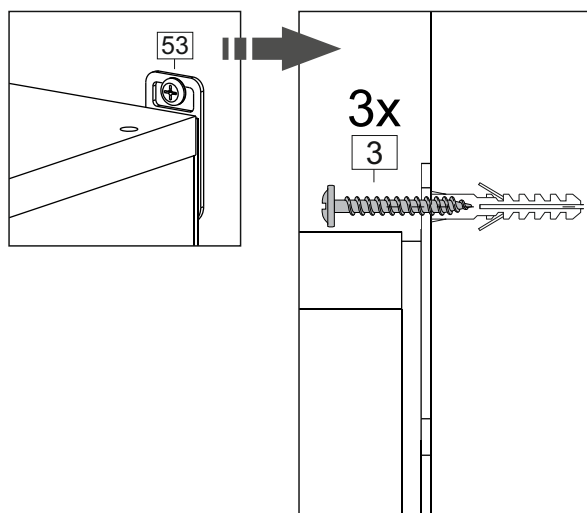
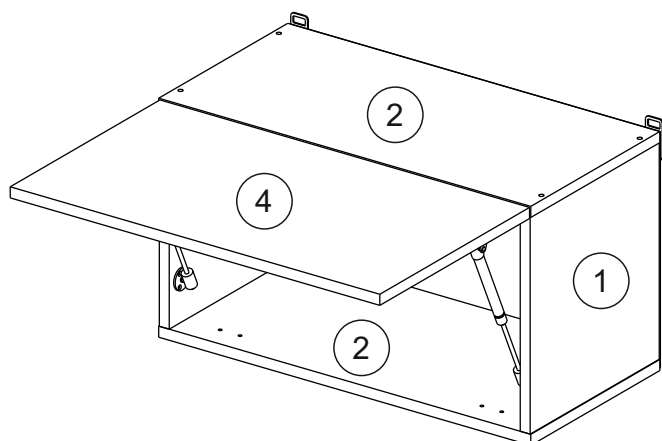
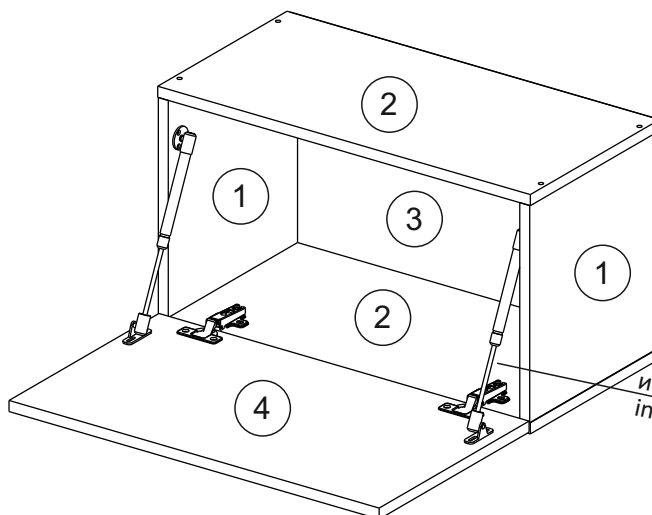
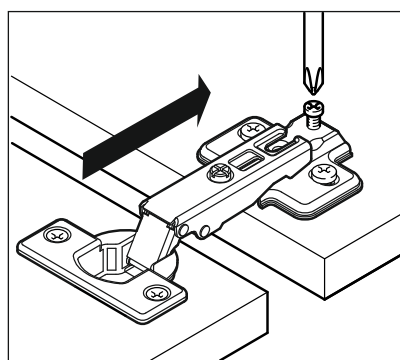
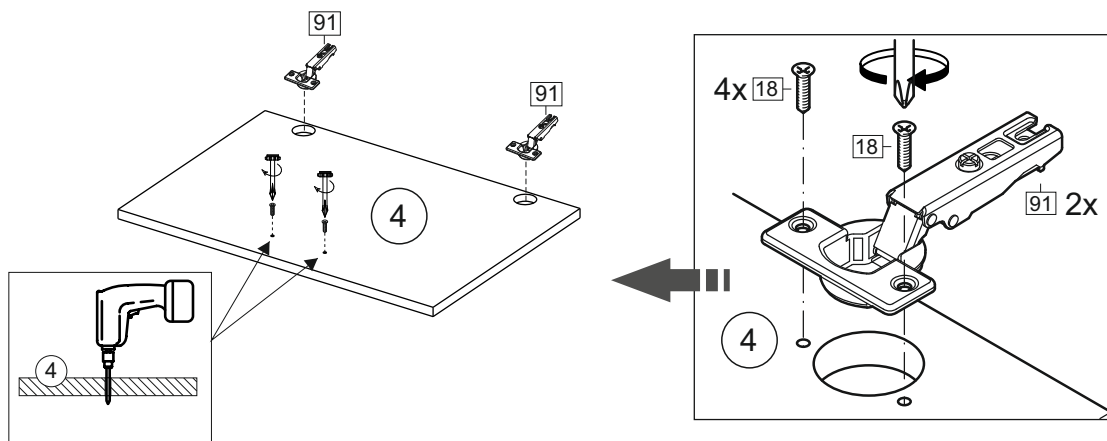
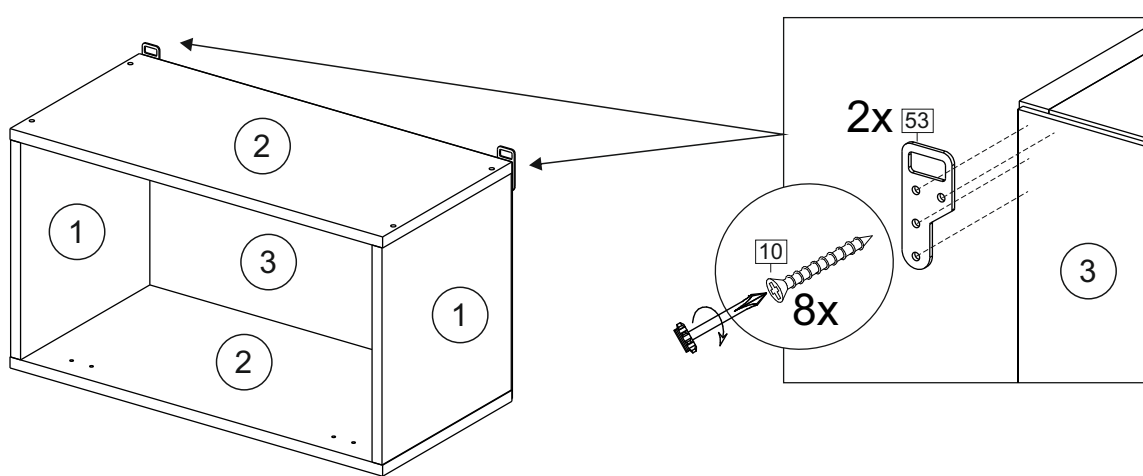

(PL) Instrukcja montażu

(CZ) Návod k montáži

(D) Montageanleitung

(GB) Assembly instruction

(F) Model d'emploi

(HU) Szerelési útmutató

(I) Istruzione di montaggio

(NL) Handleiding voor de montage

(RU) Инструкция по монтажу

(RO) Instrucțiuni de montare

(SK) Návod k montáži

(TR) Montaj talimatı



⚠ Uwaga • Upozornění • Achtung • Attention • Caution • Figyelem • Attenzione • Opgelet • Внимание • Atenție • Upozornenie • Dikkat ⚠

PL	Czyszczenie należy wykonać wyłącznie za pomocą ściereczki lub lekko nawilżonego ręcznika. Nie stosować środków czyszczących do szorowania.
CZ	Čistění je nutné vykonávat výhradně pomocí utěrky nebo lehce navlhčeného ručníku. Nepoužívejte čisticí prostředky obsahující abrazivní částice.
D	Bitte nur mit einem Staubtuch oder leicht feuchtem Lappen reinigen. Keine scheuernden Putzmittel verwenden.
GB	Please only clean with a duster or a damp cloth. Do not use any abrasive cleaners.
F	Le nettoyage se fait uniquement à l'aide d'un torchon ou d'une serviette légèrement mouillée.
HU	A tisztítás kizárólag törölrőruha vagy enyhén nedvesített törölköző segítségével végezhető. Súroló hatású tisztítószerket nem szabad használni.
I	Pulire esclusivamente con un panno o un asciugamano umido.
NL	Reinig alleen met een stofdoek of een lichtjes vochtige doek. Gebruik geen schurende poetsmiddelen.
RU	Очищайте от пыли тряпкой или слегка влажной ветошью. Не допускается применение чистящих средств, не предназначенных для ухода за мебелью.
RO	Curățarea trebuie efectuată numai cu o cârpă sau cu un prosop ușor umezit. Nu utilizați agenți de curățare abrazivi.
SK	Čistení je nutné vykonávať výhradne pomocí utierky alebo ľahko zvlhnutým ručníkom. Nepoužívajte čistiace prostriedky obsahujúci abrazívni častice.
TR	Lütfen sadece bir toz bezilye veya hafif nemli yumuşak bir bezle siliniz. Aşındırıcı temizlik malzemeleri kullanmayınız.



Karta serwisowa • Servisní list • Service Karte • Service card • Carte de service • Szervizkártya • Scheda di servizio • Service kaart • Сервисная карта • Fisa service • Servisný list • Servis karti

