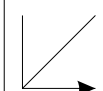
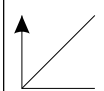
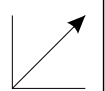

Шкаф-стол под духовку 60
(Kitchen base unit oven 60)

Код ТН ВЭД ЕАЭС

9403 40 100 0
9403 90 300 0

отрезать
и приклеить

		
600	840	430

корпус - 70Д60Б1614

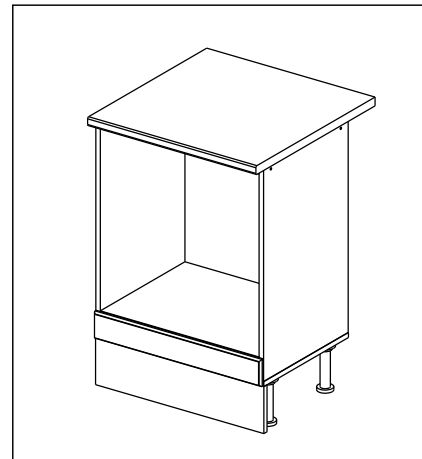
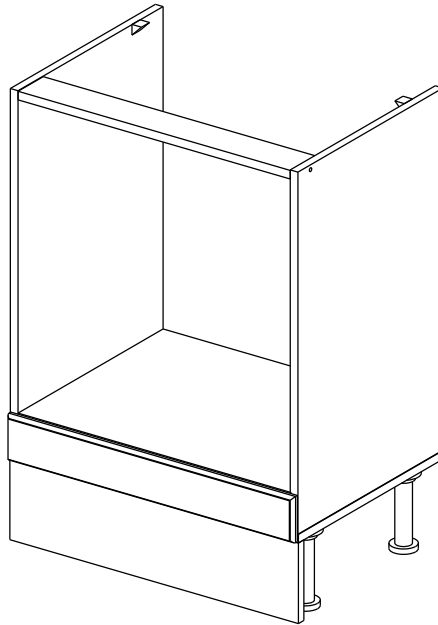





Комплектовочная ведомость / Set package sheet

Упак/ Package	Наименование	Description	Цвет детали/Décor		Размер / Size, mm	Кол-во/ Quantity	№
Package case	Фурнитура	Furniture/Cabinetry hardware	-	-	-	1	-
	Бок левый	Side left	Белый	White	674x426	1	1
	Бок правый	Side right	Белый	White	674x426	1	2
	Вязка	Connecting element	Белый	White	566x74	1	3
	Вязка	Connecting element	Белый	White	566x426	1	7
	Крышка	Top	Белый	White	600x426	1	4
	Цоколь	Socle	Белый	White	152x600	1	6

Продается отдельно/Sold separately

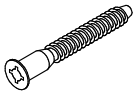
Package	Панель	Panel	см упак/look at the package	86x596	1	5
---------	--------	-------	--------------------------------	--------	---	---

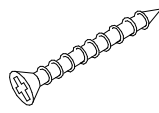
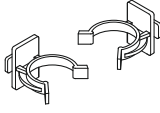
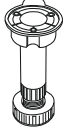
Pack	Столешница	Worktop	см упак/look at the package	600x600	1	8
------	------------	---------	-----------------------------	---------	---	---

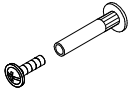
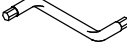
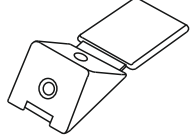
5	7*50	18	3,5*15	14	3,5*30	34	35	H 150 mm
								
10 x		34 x		4 x		2 x	4 x	
72		9		15		44		
								
6 x		2 x		1 x		5 x		

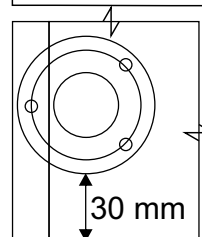
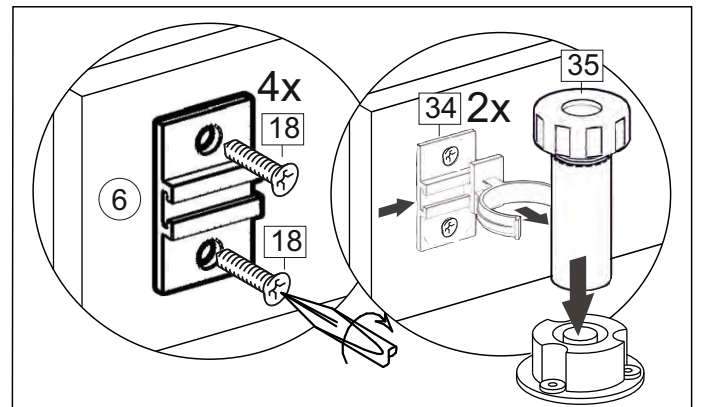
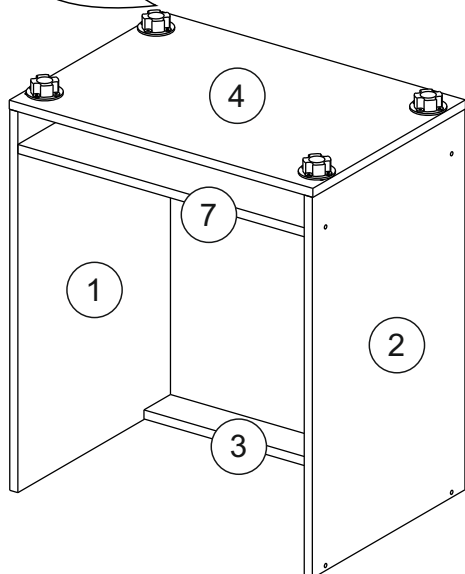
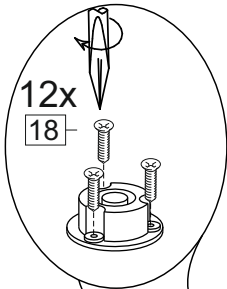
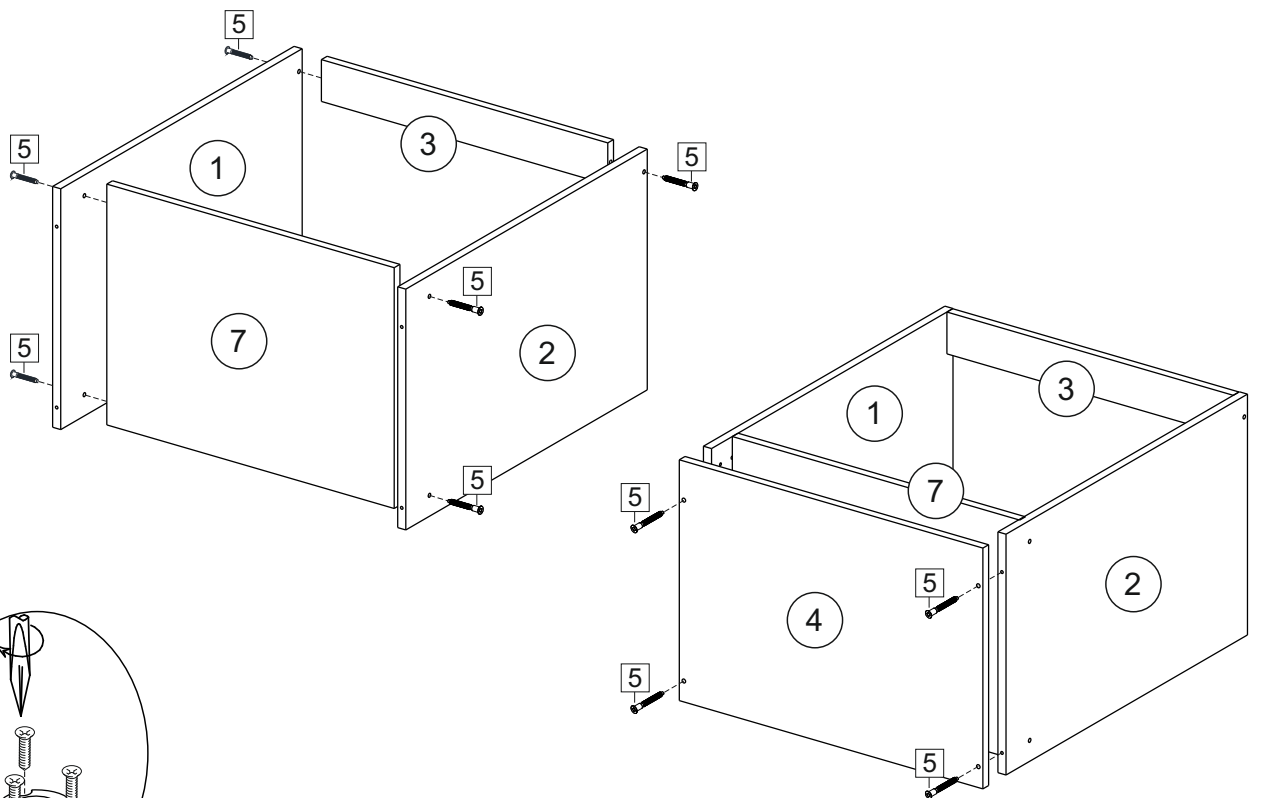
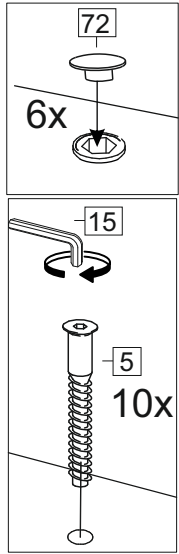

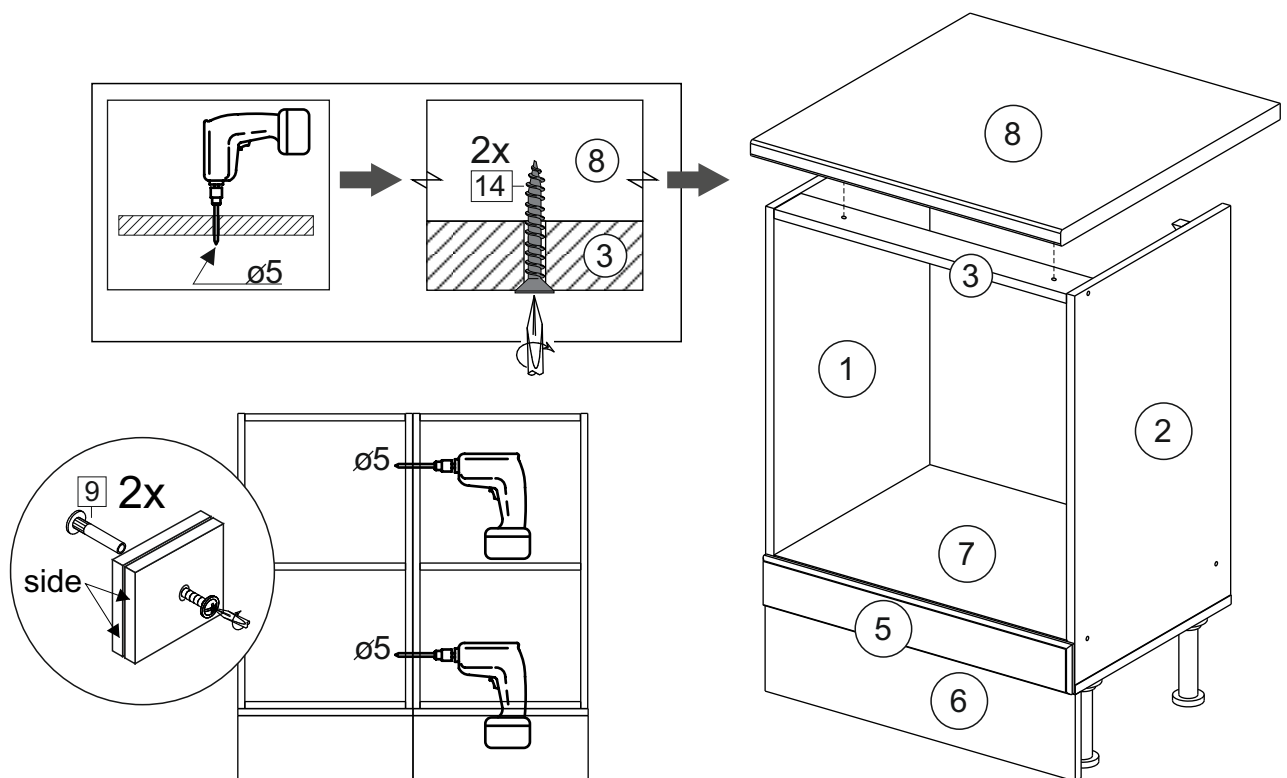
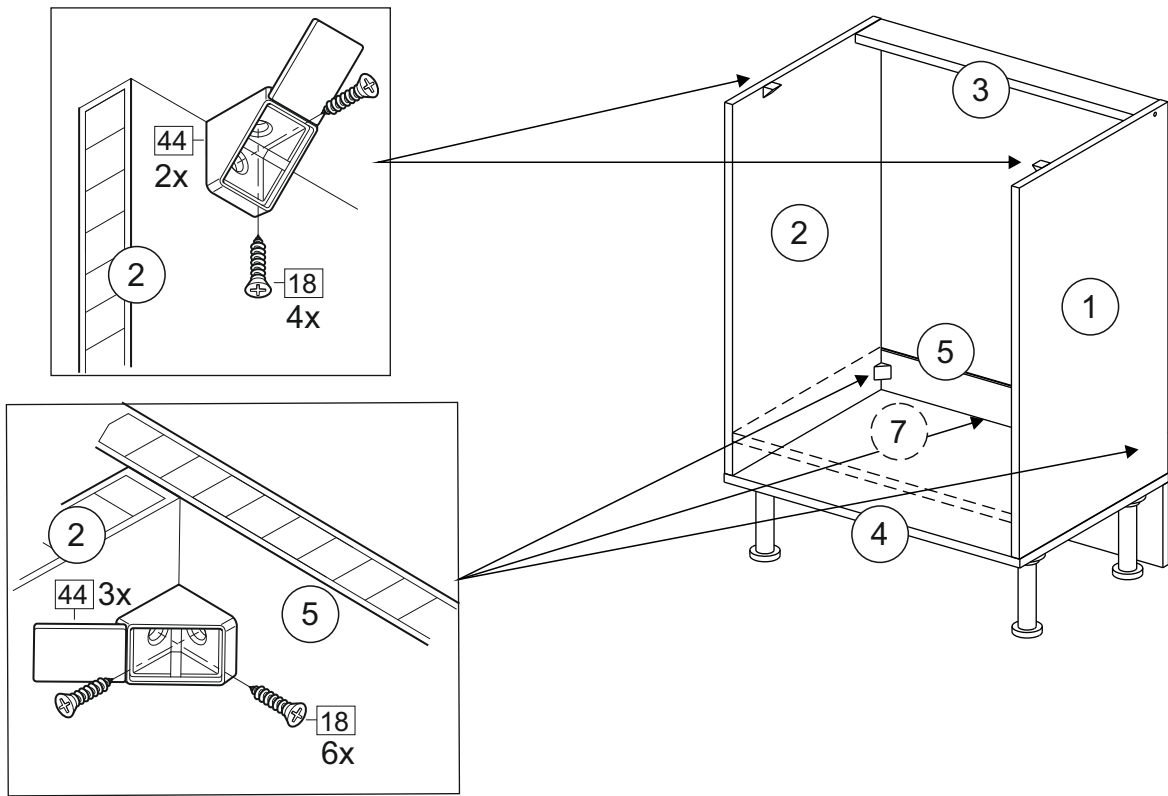

(PL) Instrukcja montażu

(CZ) Návod k montáži

(D) Montageanleitung

(GB) Assembly instruction

(F) Model d'emploi

(HU) Szerelési útmutató

(I) Istruzione di montaggio

(NL) Handleiding voor de montage

(RU) Инструкция по монтажу

(RO) Instrucțiuni de montare

(SK) Návod k montáži

(TR) Montaj talimatı



⚠ Uwaga • Upozornění • Achtung • Attention • Caution • Figyelem • Attenzione • Opgelet • Внимание • Atenție • Upozornenie • Dikkat ⚠

PL	Czyszczenie należy wykonać wyłącznie za pomocą ściereczki lub lekko nawilżonego ręcznika. Nie stosować środków czyszczących do szorowania.
CZ	Čistění je nutné vykonávat výhradně pomocí utěrky nebo lehce navlhčeného ručníku. Nepoužívejte čisticí prostředky obsahující abrazivní částice.
D	Bitte nur mit einem Staubtuch oder leicht feuchtem Lappen reinigen. Keine scheuernden Putzmittel verwenden.
GB	Please only clean with a duster or a damp cloth. Do not use any abrasive cleaners.
F	Le nettoyage se fait uniquement à l'aide d'un torchon ou d'une serviette légèrement mouillée.
HU	A tisztítás kizárólag törölrőruha vagy enyhén nedvesített törölköző segítségével végezhető. Súroló hatású tisztítószereket nem szabad használni.
I	Pulire esclusivamente con un panno o un asciugamano umido.
NL	Reinig alleen met een stofdoek of een lichtjes vochtige doek. Gebruik geen schurende poetsmiddelen.
RU	Очищайте от пыли тряпкой или слегка влажной ветошью. Не допускается применение чистящих средств, не предназначенных для ухода за мебелью.
RO	Curățarea trebuie efectuată numai cu o cârpă sau cu un prosop ușor umezit. Nu utilizați agenți de curățare abrazivi.
SK	Čistení je nutné vykonávať výhradne pomocou utierky alebo ľahko zvlhnutým ručníkom. Nepoužívajte čistiace prostriedky obsahujúce abrazívni častice.
TR	Lütfen sadece bir toz beziyile veya hafif nemli yumuşak bir bezle siliniz. Aşındırıcı temizlik malzemeleri kullanmayınız.

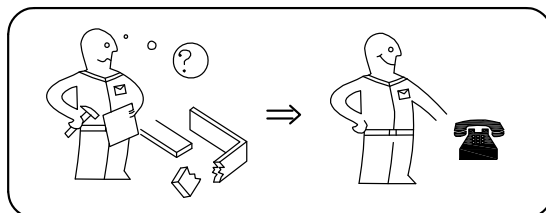
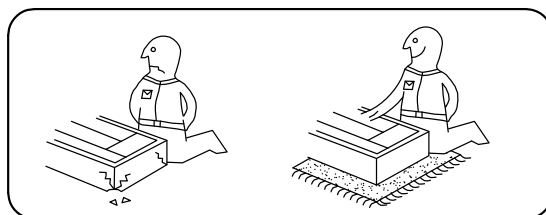

Karta serwisowa • Servisní list • Service Karte • Service card • Carte de service • Szervizkártya • Scheda di servizio • Service kaart • Сервисная карта • Fisa service • Servisný list • Servis karti

