

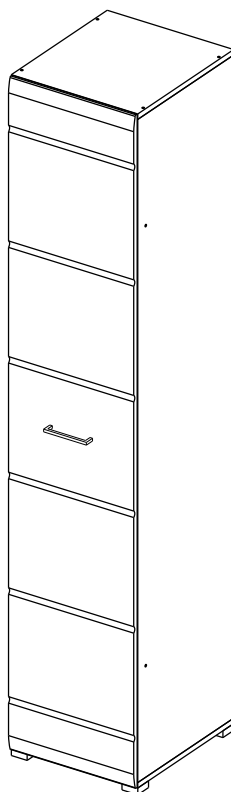



Пенал НЕНСИ / wardrobe NANCY 1 door

Код ТН ВЭД ЕАЭС

9403 60 100 1
9403 90 300 0

отрезать
и приклеить



		
400	2000	466

корпус	39НВП / 2553
	39НЯП / 2575
	39НАН06 / 3427
фасад	39ФБП / 2586
	39ФУП / 2827







Комплектовочная ведомость / Set package sheet

Упак/ Package	Наименование	Description	Décor			Размер/ Size, mm	Кол-во/ Quantity	№
			Wenge	Ash light	Craft gold			
1	Фурнитура	Furniture/Cabinetry hardware	-	-	-	-	1	-
2	Боковина левая	Side left	Wenge	Ash light	Craft gold	1950x446	1	1
	Боковина правая	Side right				1950x446	1	2
	Крыша	Top				400x446	2	3
	Вязка	Connecting element				368x446	2	4
	Полка	Shelves				368x446	2	5
	ХДФ	Back element			White	405x396	2	7
	ХДФ	Back element			White	1164x396	1	8

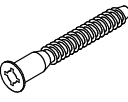
Продается отдельно/Sold separately:

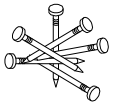
Упак/ Package	Наименование	Description	Décor		Размер/ Size, mm	Кол-во/ Quantity	№
			White gl	Cappuccino gl			
1	Створка	Door	White gl	Cappuccino gl	1980x396	1	6

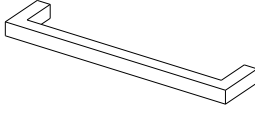
Craft gold - Крафт золотой
Ash light - Ясень светл

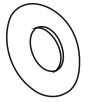
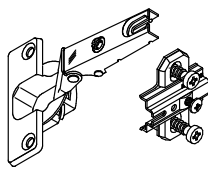
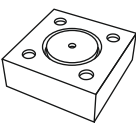
5	7x50	14	3,5x30	18	3,5x15	48	2x20	39
								
16 x		4 x		8 x		40 x		8 x
15		126	C42 128 mm	72		6	6,3x10,5	45
								
1 x		1 x		8 x		8 x		6 x
91	A	38						
								
4 x		4 x						

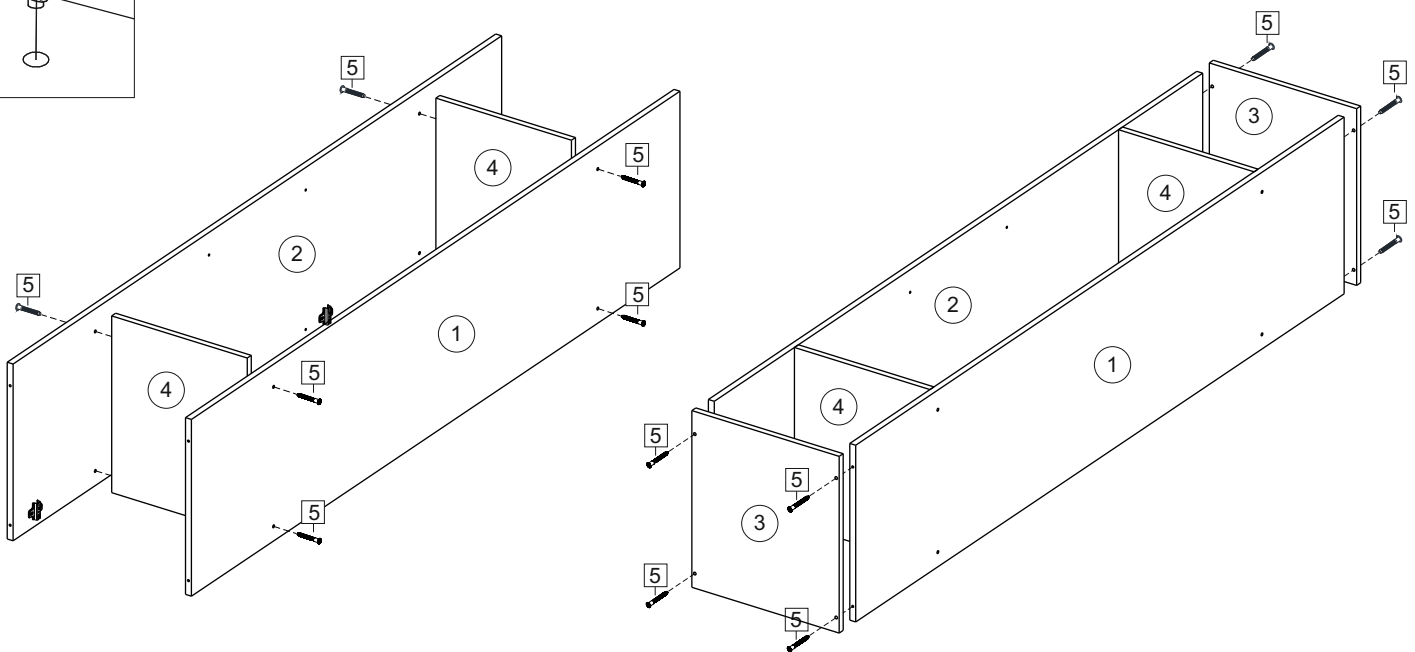
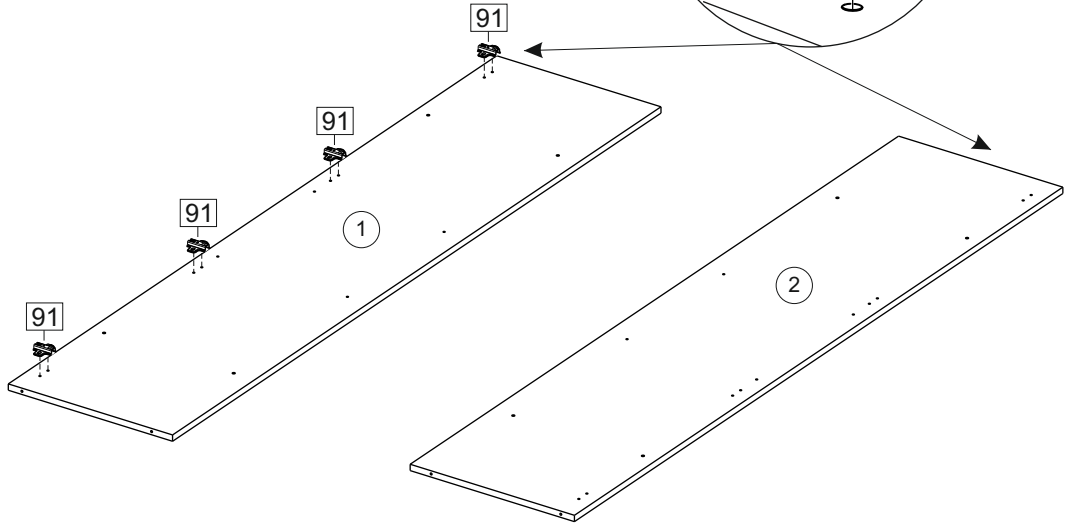
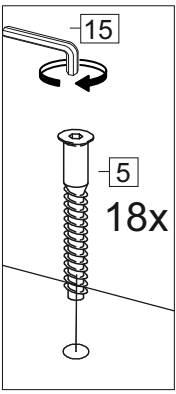
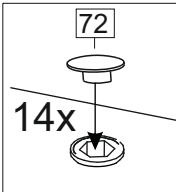
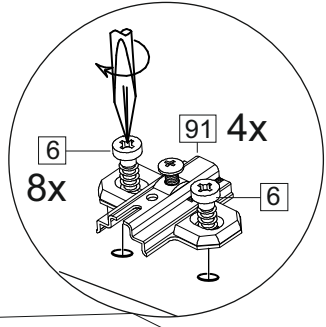

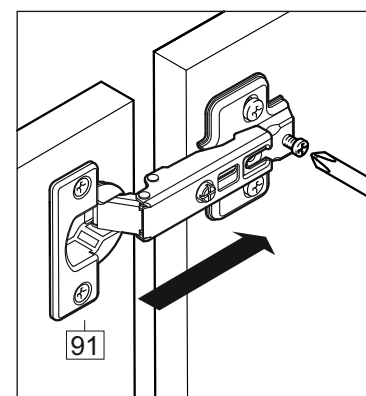
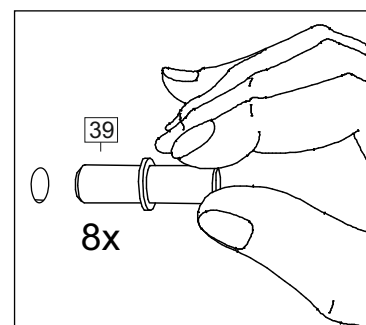
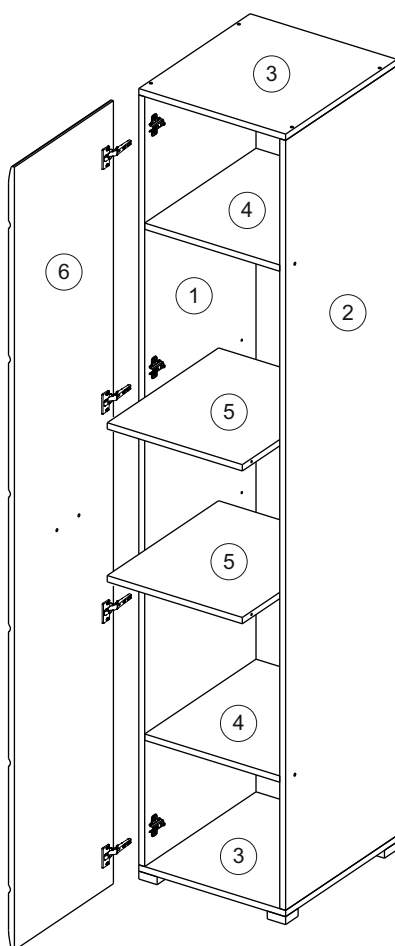
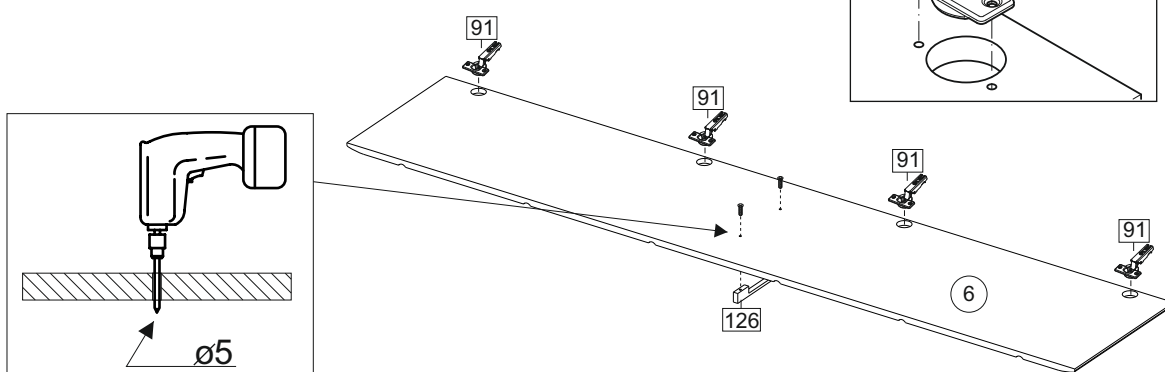
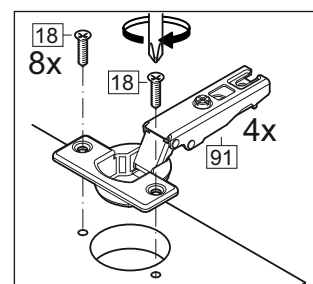
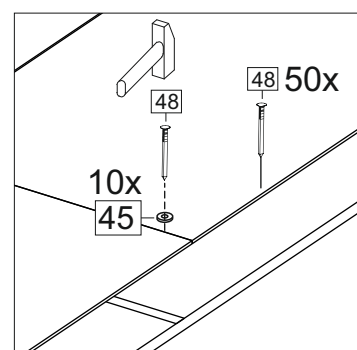
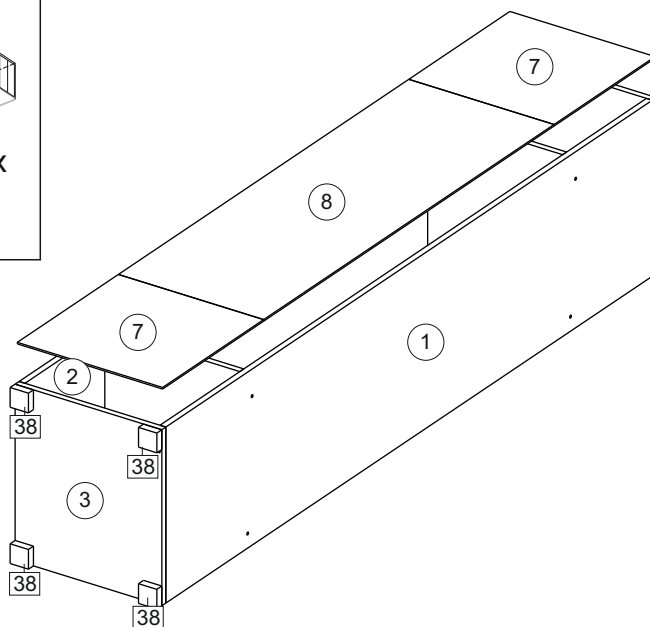
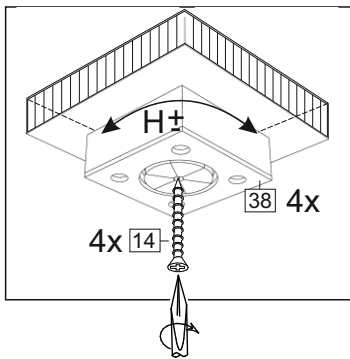

(PL) Instrukcja montażu

(CZ) Návod k montáži

(D) Montageanleitung

(GB) Assembly instruction

(F) Model d'emploi

(HU) Szerelési útmutató

(I) Istruzione di montaggio

(NL) Handleiding voor de montage

(RU) Инструкция по монтажу

(RO) Instrucțiuni de montare

(SK) Návod k montáži

(TR) Montaj talimatı



⚠ Uwaga • Upozornění • Achtung • Attention • Caution • Figyelem • Attenzione • Opgelet • Внимание • Atenție • Upozornenie • Dikkat ⚠	
PL	Czyszczenie należy wykonać wyłącznie za pomocą ściereczki lub lekko nawilżonego ręcznika. Nie stosować środków czyszczących do szorowania.
CZ	Čistění je nutné vykonávat výhradně pomocí utěrky nebo lehce navlhčeného ručníku. Nepoužívejte čisticí prostředky obsahující abrazivní částice.
D	Bitte nur mit einem Staubtuch oder leicht feuchtem Lappen reinigen. Keine scheuernden Putzmittel verwenden.
GB	Please only clean with a duster or a damp cloth. Do not use any abrasive cleaners.
F	Le nettoyage se fait uniquement à l'aide d'un torchon ou d'une serviette légèrement mouillée.
HU	A tisztítás kizárólag törölrőruha vagy enyhén nedvesített törölköző segítségével végezhető. Súroló hatású tisztítószerket nem szabad használni.
I	Pulire esclusivamente con un panno o un asciugamano umido.
NL	Reinig alleen met een stofdoek of een lichtjes vochtige doek. Gebruik geen schurende poetsmiddelen.
RU	Очищайте от пыли тряпкой или слегка влажной ветошью. Не допускается применение чистящих средств, не предназначенных для ухода за мебелью.
RO	Curățarea trebuie efectuată numai cu o cârpă sau cu un prosop ușor umezit. Nu utilizați agenți de curățare abrazivi.
SK	Čistení je nutné vykonávať výhradne pomocou utierky alebo ľahko zvlhnutým ručníkom. Nepoužívajte čistiace prostriedky obsahujúce abrazívni častice.
TR	Lütfen sadece bir toz beziyile veya hafif nemli yumuşak bir bezle siliniz. Aşındırıcı temizlik malzemeleri kullanmayınız.



**Karta serwisowa • Servisní list • Service Karte • Service card • Carte de service • Szervizkártya
Scheda di servizio • Service kaart • Сервисная карта • Fisa service • Servisný list • Servis karti**

