

Prevista Dry WC element object variant

Instructions for Use

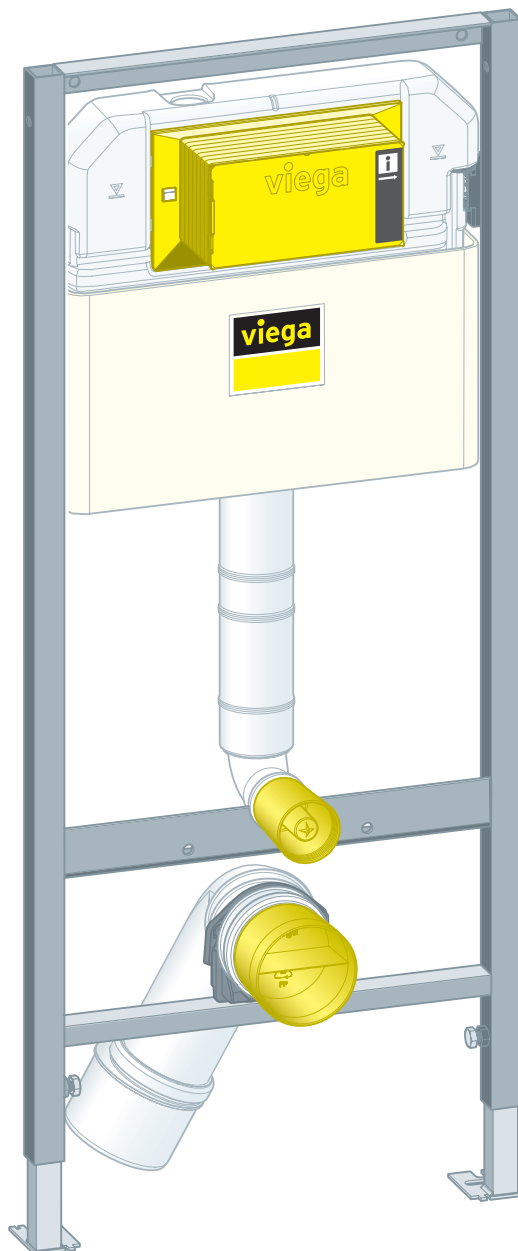

for WC flush plates for Prevista

Model
8524

Year built:
from 09/2018

en_INT



Prevista Dry WC element object variant

2 from 22

Table of contents

1	About these instructions for use	4
1.1	Target groups	4
1.2	Labelling of notes	4
1.3	About this translated version	5
2	Product information	6
2.1	Standards and regulations	6
2.2	Intended use	6
2.2.1	Areas of use	6
2.3	Product description	6
2.3.1	Overview	6
2.3.2	Compatible components	7
2.3.3	Technical data	8
3	Handling	9
3.1	Assembly information	9
3.1.1	Mounting conditions	9
3.1.2	Installation dimensions	10
3.2	Assembly	10
3.2.1	Mounting WC element	10
3.2.2	Connecting concealed cistern	14
3.2.3	Mounting the drain elbow	17
3.2.4	Set and clad the WC element	18
3.2.5	Setting the flush volume	20
3.3	Cleaning and maintenance	22
3.4	Disposal	22

1 About these instructions for use

Trade mark rights exist for this document; for further information, go to viega.com/legal.

1.1 Target groups

The information in this instruction manual is directed at the following groups of people:

- Heating and sanitary professionals and trained personnel
- Drywall builder

Individuals without the abovementioned training or qualification are not permitted to mount, install and, if required, maintain this product. This restriction does not extend to possible operating instructions.

The installation of Viega products must take place in accordance with the general rules of engineering and the Viega instructions for use.

1.2 Labelling of notes

Warning and advisory texts are set aside from the remainder of the text and are labelled with the relevant pictographs.

**DANGER!**

This symbol warns of possible life-threatening injury.

**WARNING!**

This symbol warns of possible serious injury.

**CAUTION!**

This symbol warns of possible injury.

**NOTICE!**

This symbol warns of possible damage to property.



This symbol gives additional information and hints.

1.3 About this translated version

This instruction for use contains important information about the choice of product or system, assembly and commissioning as well as intended use and, if required, maintenance measures. The information about the products, their properties and application technology are based on the current standards in Europe (e.g. EN) and/or in Germany (e.g. DIN/DVGW).

Some passages in the text may refer to technical codes in Europe/ Germany. These should serve as recommendations in the absence of corresponding national regulations. The relevant national laws, standards, regulations, directives and other technical provisions take priority over the German/European directives specified in this manual: The information herein is not binding for other countries and regions; as said above, they should be understood as a recommendation.

2 Product information

2.1 Standards and regulations

The following standards and regulations apply to Germany / Europe and are provided as a support feature.

Regulations from section: Fields of application / Mounting conditions

Scope / Notice	Regulations applicable in Germany
Suitable masonry walls	EN 1996-1-1
Suitable concreted walls	DIN 1045
Suitable support profiles	DIN 18183

2.2 Intended use

2.2.1 Areas of use

The Prevista Dry WC element is suitable for mounting on masonry wall constructions and support profiles pursuant to the regulations in section [↗](#) „Regulations from section: Fields of application / Mounting conditions“ on page 6.

2.3 Product description

2.3.1 Overview

The WC element is equipped as follows:

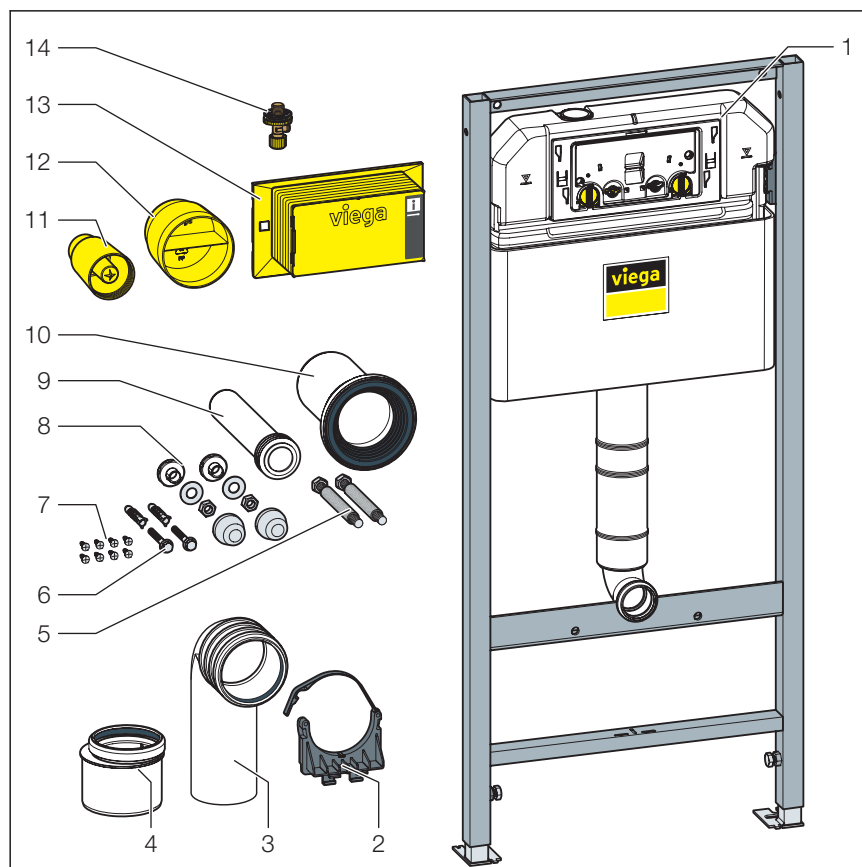

Fig. 1: Components

- 1 3H concealed cistern
- 2 Holder for drain elbow
- 3 Drain elbow
- 4 Reducer
- 5 Threaded rods for fixing sanitary objects (gauges for bore hole 180 mm)
- 6 Screws and dowels for fixing in the floor
- 7 Screws for fixing in support profile
- 8 Mounting set for WC ceramic
- 9 Flushing pipe
- 10 WC connection socket with lip seal
- 11 Protective plug for flushing pipe elbow
- 12 Protective plug for drain elbow DN90
- 13 Revision shaft cover
- 14 Corner valve

2.3.2 Compatible components

The WC element is compatible with all common WC ceramics, even with larger projection (barrier-free).

The WC element can be extended by the following compatible components:

- Prevista Dry fixing element
- Prevista Dry fixing set model 8573

- Fixing set model 8180.73
- Accessory set connection electronic model 8655.11

Mount the components in accordance with the respective instructions for use.

2.3.3 Technical data

Flush volume

Small flush volume	Factory setting	approx. 3 l
	Setting range	approx. 2–4 l
Large flush volume	Factory setting	approx. 6 l
	Setting range	approx. 3.5–7.5 l

3 Handling

3.1 Assembly information

3.1.1 Mounting conditions

Suitable walls

- Masonry walls
- Concreted walls
- Metal support profiles

The wall constructions must comply with the regulations in section  „Regulations from section: Fields of application / Mounting conditions“ on page 6.

The WC element may only be mounted on even wall surfaces.

Construction height

With the construction height, the marked height of the upper edge of the finished floor must be observed.

Installation depth

The installation depth is maximum 200 mm.

WC ceramic

The WC element can only be used in combination with wall-hung WCs (fixing gauges for bore hole 180 mm).

Water connection

The WC element has an R ½ inch water connection.

Actuation versions

The WC element can be extended by a remote flush actuation or by an electronic actuation, as well as by sensitive flush plates. The cables for these electrical actuation versions must be laid in front of the cladding.

The corresponding empty pipe is required when preparing the remote flush actuation.

3.1.2 Installation dimensions

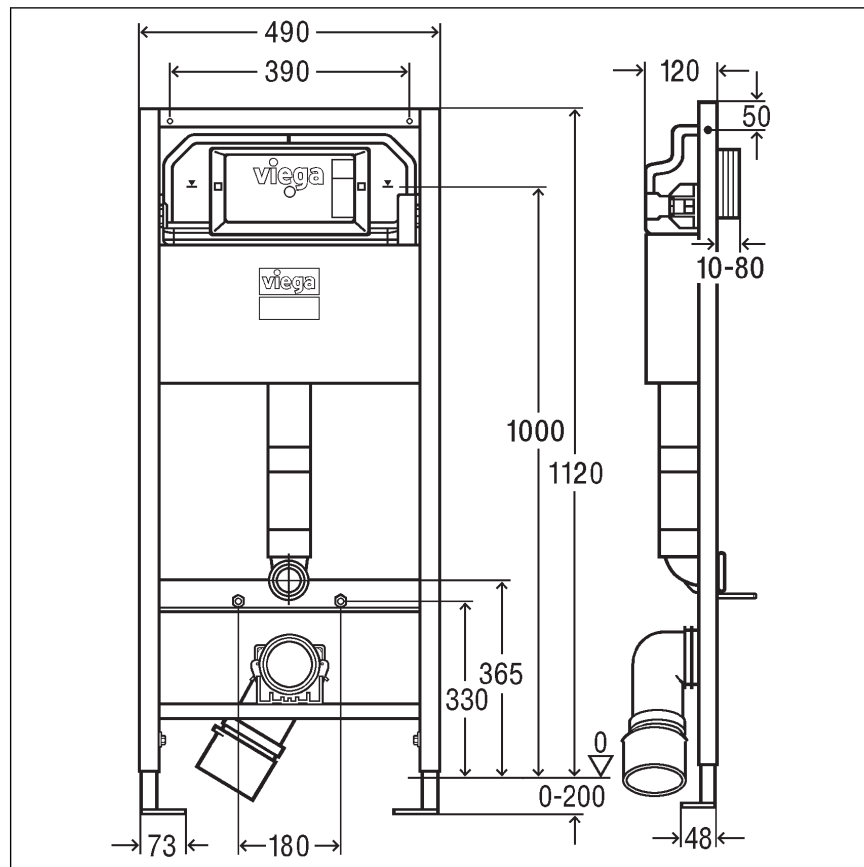

Fig. 2: Dimensional drawing

3.2 Assembly

3.2.1 Mounting WC element



Masonry and concreted walls

When mounting multiple WC elements with an interval of > 500 mm, Viega recommends the use of a Prevista Dry support bracket (model 8570.48). Observe the instructions for use of the support bracket when mounting.

Mounting to a masonry wall



For mounting, Viega recommends to use the fixing set (model 8180.73).

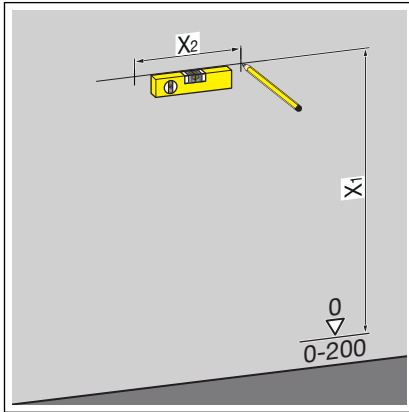

► Determine and mark the fixing points.

- X1: 1100 mm
- X2: 390 mm

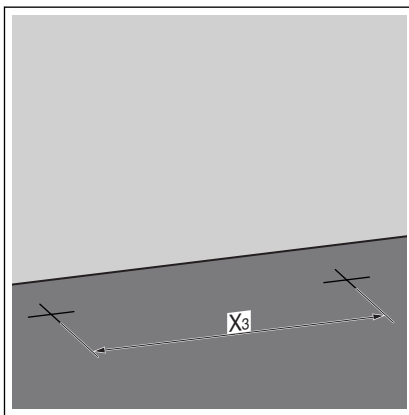

► Determine and mark the fixing points on the floor.

- X3: 400 mm

► Drill the holes.

► Insert the dowels.

INFO! Mount the fixing set (model 8180.73) pursuant to the instructions for use for the fixing set.

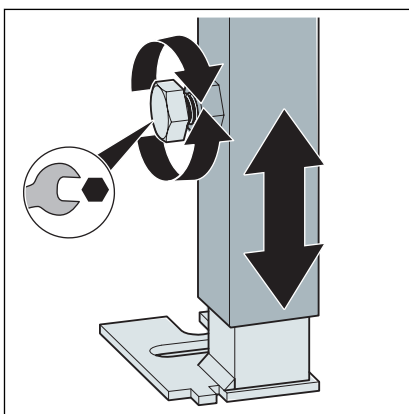

► Loosen the feet of the element using a fork spanner.

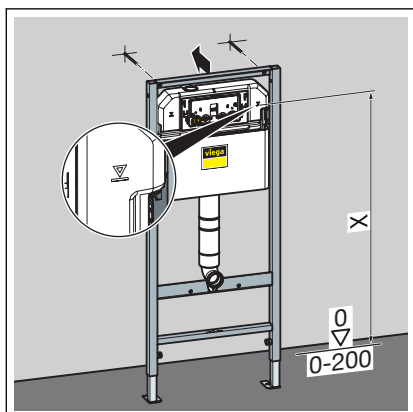

► Adjust the construction height of the element in accordance with the on-site marking of the upper edge of the finished floor.

■ X: 1000 mm

► Tighten the feet of the element using a fork spanner.

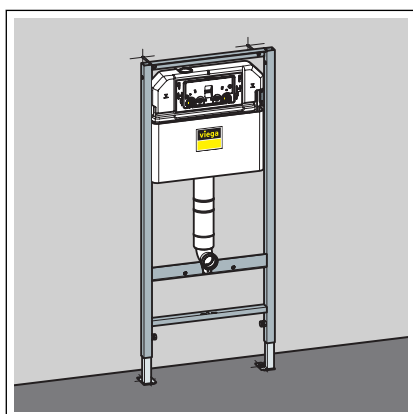

⇒ The element is attached to the wall.

Mounting in metal support profile

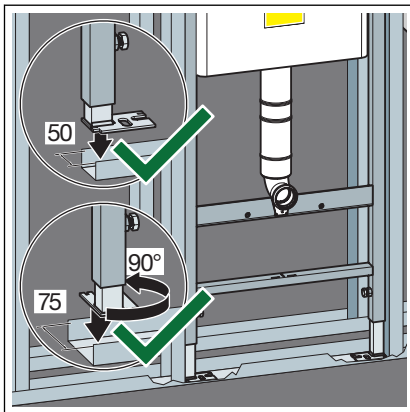

- Position the element on the floor rail.
- If necessary, adjust the foot depth from 50 mm (pre-mounted) to 75 mm.
- Loosen and pull out the foot plates.
- Turn the foot plates through 90°.
- Screw the feet together with the support profile.

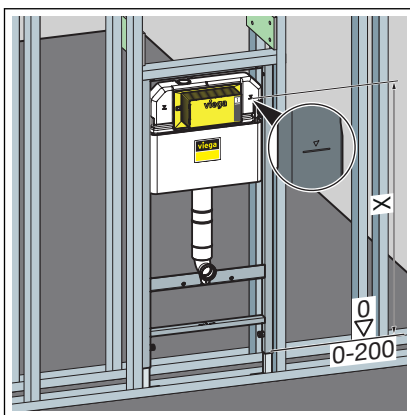

- Adjust the construction height of the element in accordance with the on-site marking of the upper edge of the finished floor.
 - X: 1000 mm

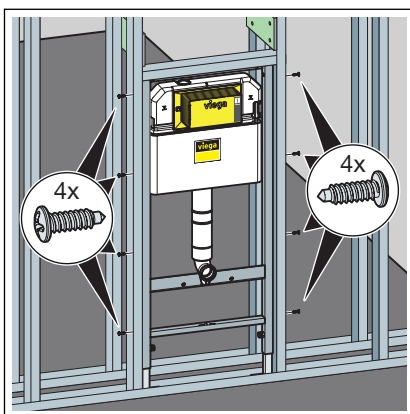

- Attach the element to the support profiles using the screws supplied.

3.2.2 Connecting concealed cistern

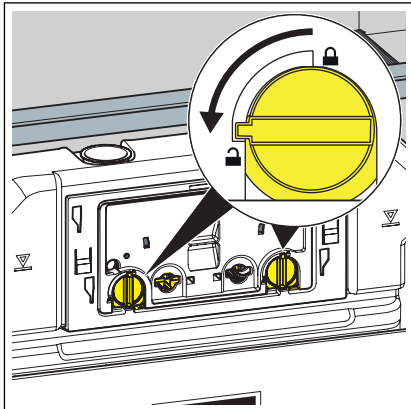

- Turn the cover plate lock 90° in anti-clockwise direction.

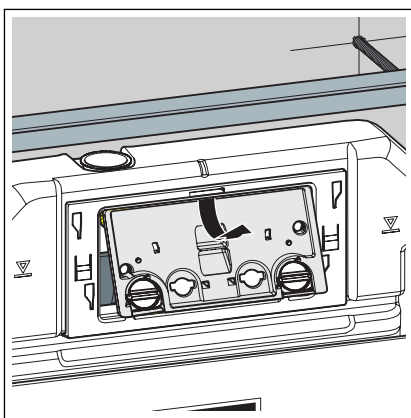

- Remove the cover plate.

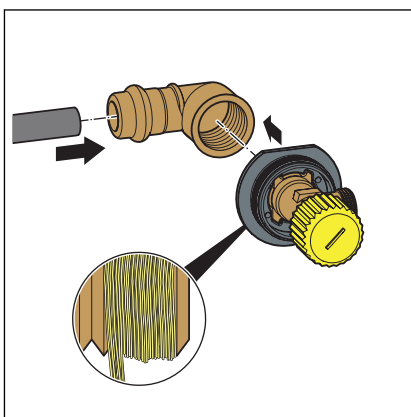

- Place the press connector on the water inlet.
- Press the connection.
- Seal the threaded connectors of the corner valve.
- Screw the corner valve into the thread side of the Steptec rail connector.

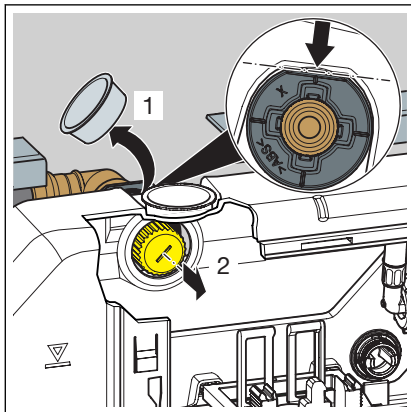

- Remove the plug.
- Insert the corner valve into the cistern.

INFO! Ensure the corner valve is correctly seated.

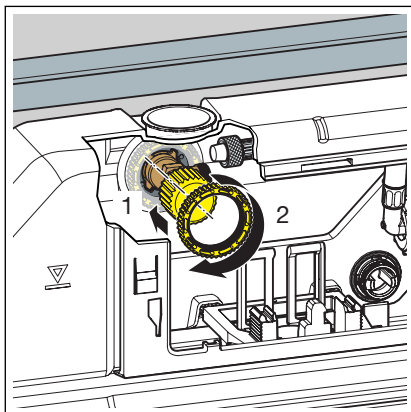

- Use the lock nut to screw the corner valve and the cistern to one another.

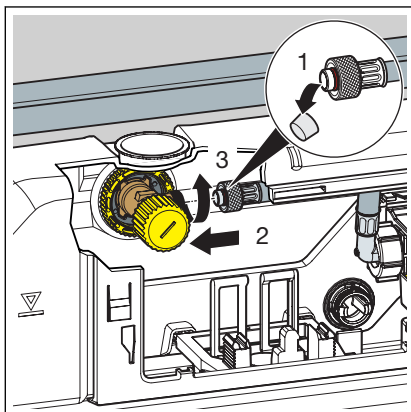

- Remove the protective cap from the water supply hose.
- Screw the water supply hose and the corner valve to one another.

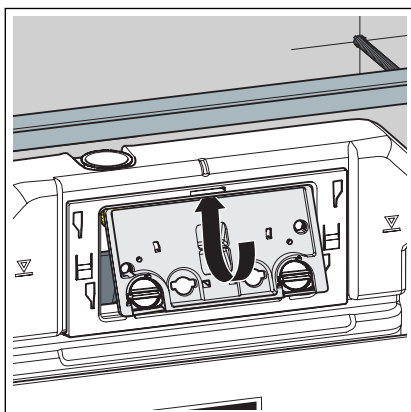

- Insert the cover plate into the cistern.

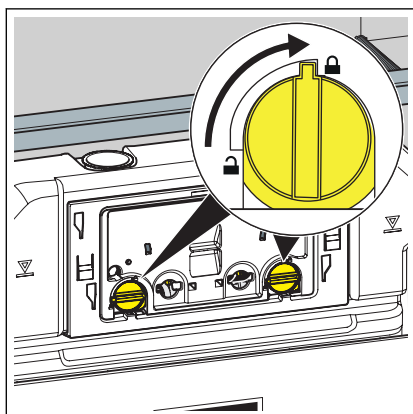

► Turn the cover plate lock by 90° in a clockwise direction.

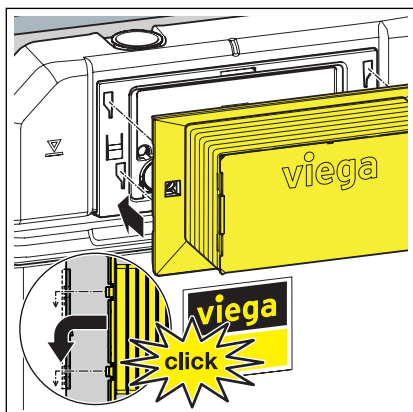

► Place the revision shaft on the cover plate.

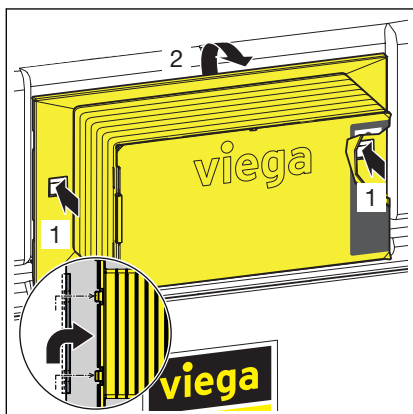

To remove the revision shaft, press in the fixing clips at the side.

3.2.3 Mounting the drain elbow

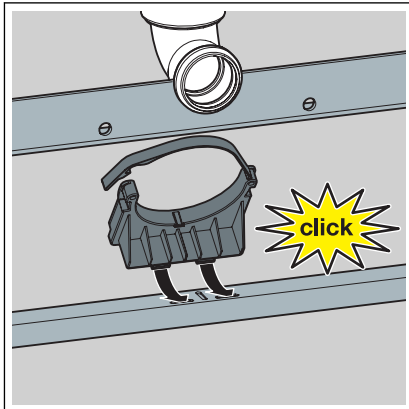

- Insert the mounting bracket for the drain elbow.

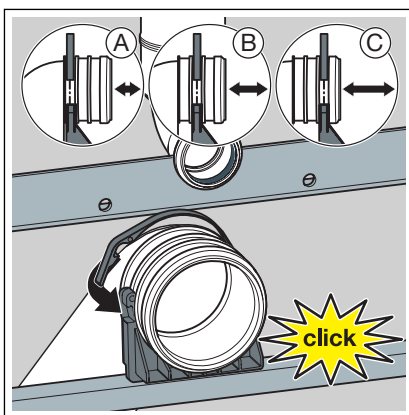

- Insert the drain elbow to the desired depth.
- Secure the drain elbow using the bow.

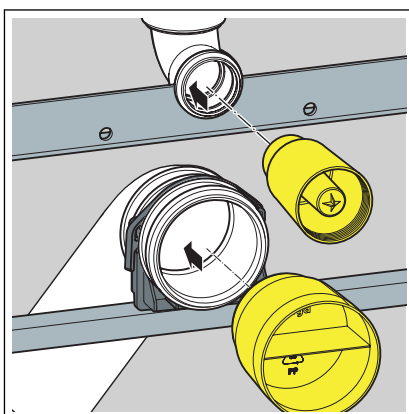

- Attach the protective plug of the flushing pipe elbow.
- Put the protective plug of the drain elbow on.

3.2.4 Set and clad the WC element

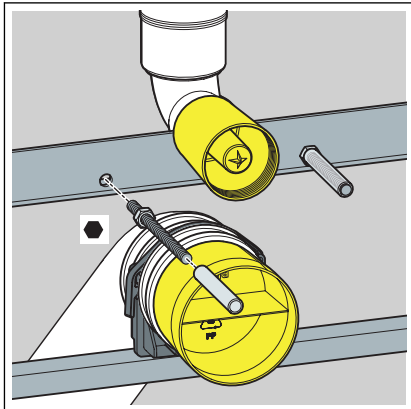

- Turn in the threaded rods by hand.
For 180 mm gauge for bore hole: Counter the threaded rods in front of the element with a nut.
- Place the protective caps on the threaded rods.

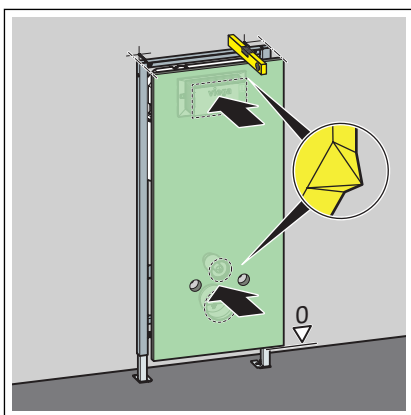

- Corn the gypsum cardboard cladding panel at the revision shaft and at the site protection by applying gentle pressure.

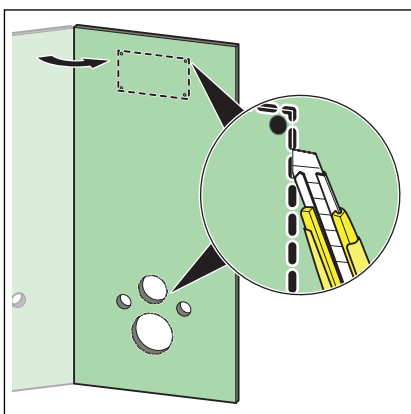

- Cut out the recesses for the site protection, the revision shaft and the threaded rods.

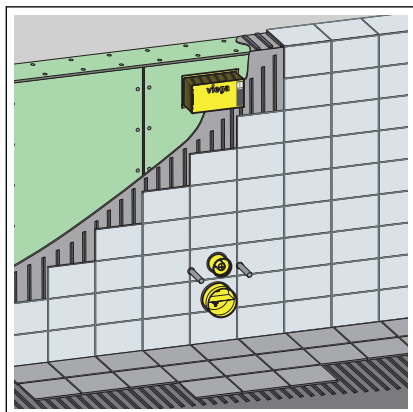

- Clad the element with suitable gypsum cardboard cladding panels.

3.2.5 Setting the flush volume

Requirements:

- The cistern is freely accessible.
- The water supply has been shut off.
- The ceramic has been mounted.
- Fold the tabs forward.

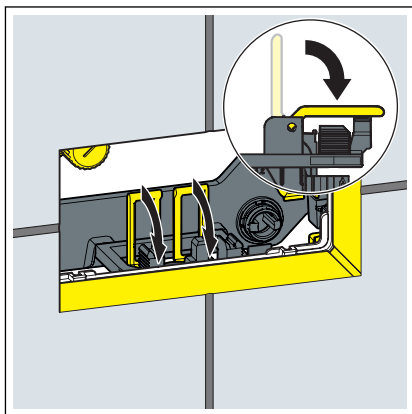

- Lift the drain valve.

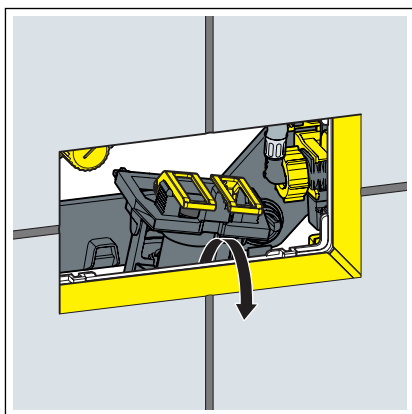

- Remove the drain valve through the revision opening.

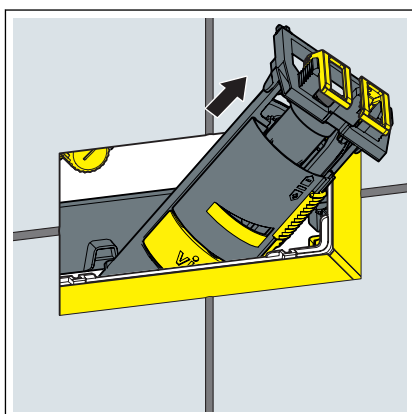

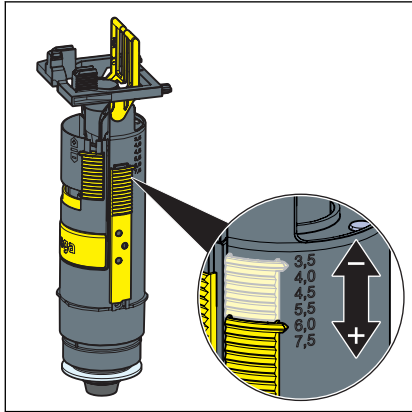

► Set the large flush volume at the drain valve.

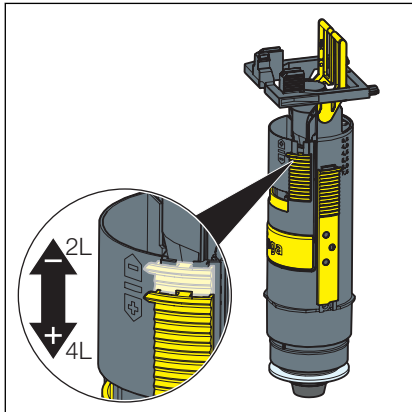

► Set the small flush volume at the drain valve.

Setting the flush flow

Requirements:

- The drain valve has been dismantled.
- The flushing throttle has been removed.
- Unlock the flushing throttle.
- Set the flush flow at the throttle.

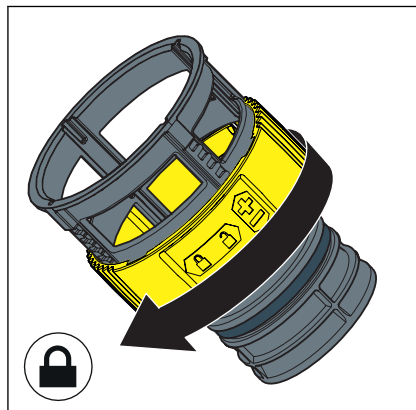
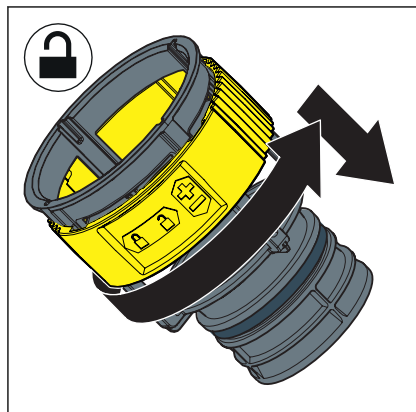

- Lock the flushing throttle.

3.3 Cleaning and maintenance

Cleaning and maintenance of the concealed cistern

The concealed cistern is constantly under mechanical, chemical, and physical stress. For this reason, the components must be cleaned as required, and the drain and filling valve seals renewed.

In areas or regions with hard water due to high concentration of calcium or magnesium salts, there is the risk of limescale deposits developing on the inlet and drain valves. The valves may have to be replaced, depending on the extent of the deposits.

3.4 Disposal

Separate the product and packaging materials (e. g. paper, metal, plastic or non-ferrous metals) and dispose of in accordance with valid national legal requirements.