

Обувница ТАНГО (СМАРТ) XXL/ Shoes cupboard TANGO (SMART) XXL

Код ТН ВЭД ЕАЭС

9403 60 100 1
9403 90 300 0

отрезать
и приклеить

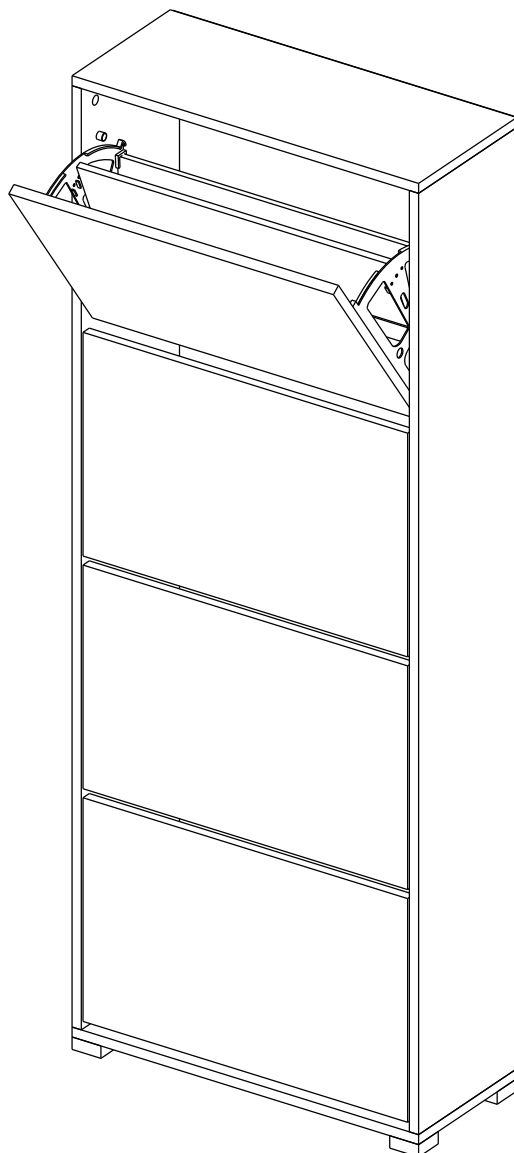









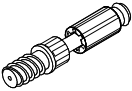

600	1567	250

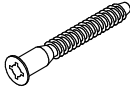
47ПТ51348

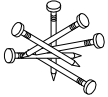
46ПТ31343

Комплектовочная ведомость/ Set package sheet

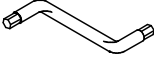
Упаковка/ Package	Наименование	Description	Décor		Размер/ Size, mm	Кол-во/ Quantity	№
			Canter - Sonoma	Oak cantri- Oak Provence			
1	Фурнитура	Furniture/Cabinetry hardware	-	-	-	1	-
	Бок левый	Side left	Canter	Oak cantri	1515x250	1	1
	Бок правый	Side right	Canter	Oak cantri	1515x250	1	2
	Крышка низ	Top low	Canter	Oak cantri	600x250	1	3
	Крышка верх	Top high	Canter	Oak cantri	600x250	1	4
	Полка 10 мм	Shelves 10 mm	Sonoma	Sonoma	552x135	8	5
	Полка 10 мм	Shelves 10 mm	Sonoma	Sonoma	552x87	4	6
	ДВП	Back element	Sonoma	Sonoma	385x596	4	8
	Соед. Элемент	Connecting back element	-	-	566 mm	3	9
	Фасад	Door	Sonoma	Oak Provence	360x562	4	7

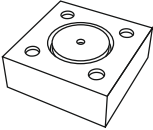
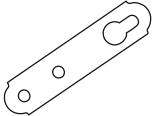
1		2		5	7x50	6	6,3x10,5	48	
									
4 x		4 x		4 x		24 x		30 x	
80	Shoe rack fitting	18	3,5x15	14	3,5x30	15		73	
									
4 x		28 x		4 x		0 x		4 x	
38		27							
									
4 x		2 x							

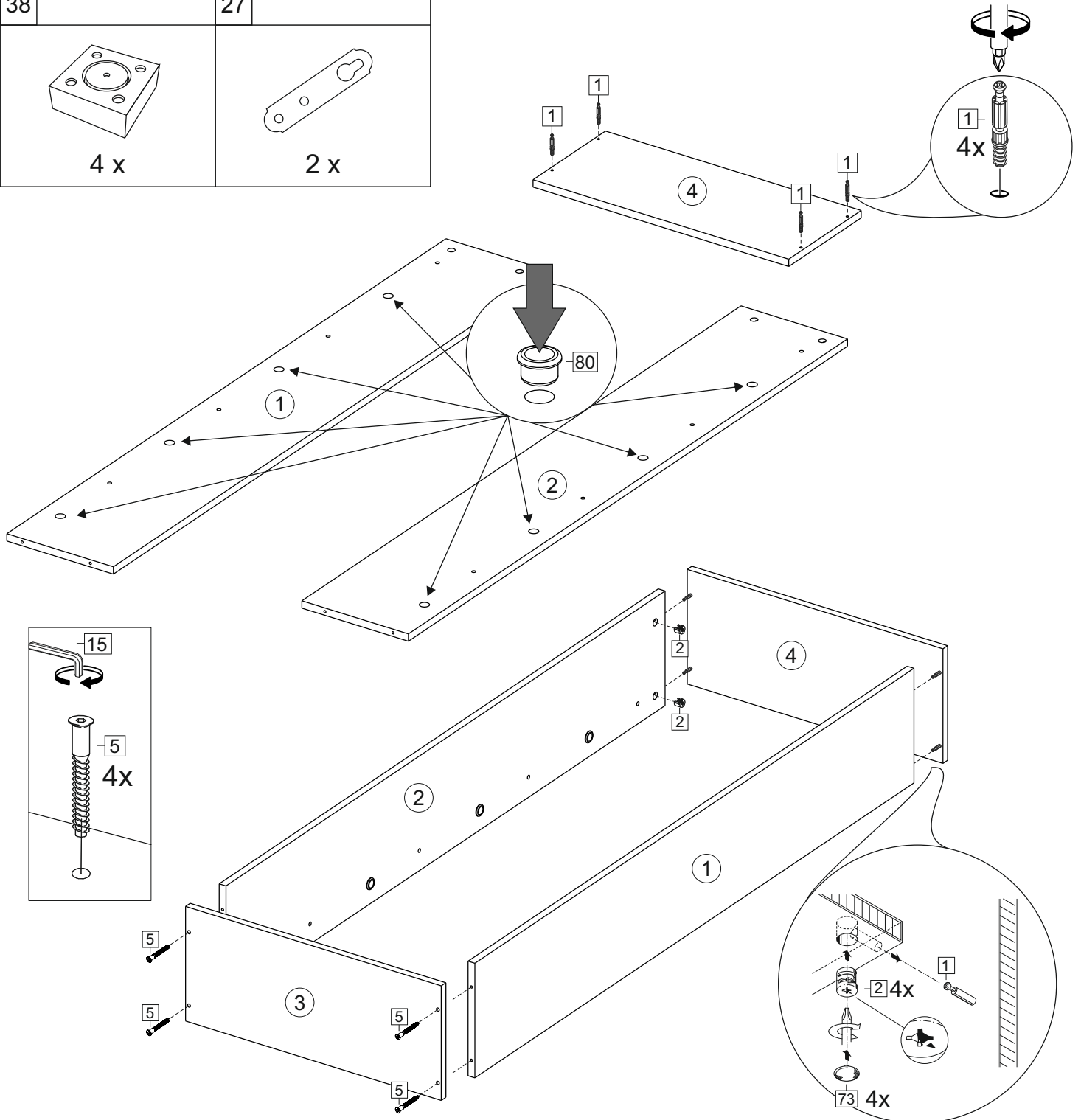

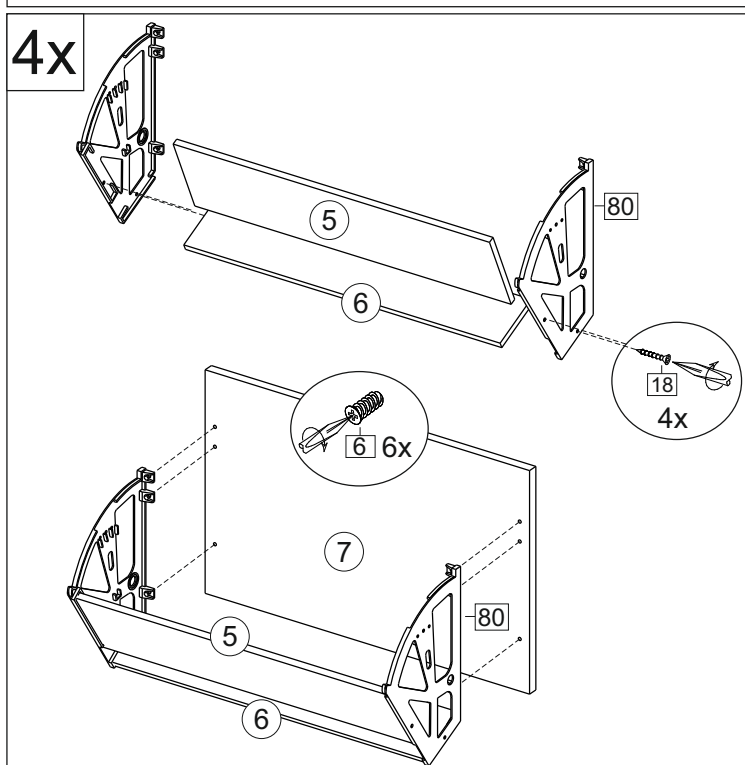
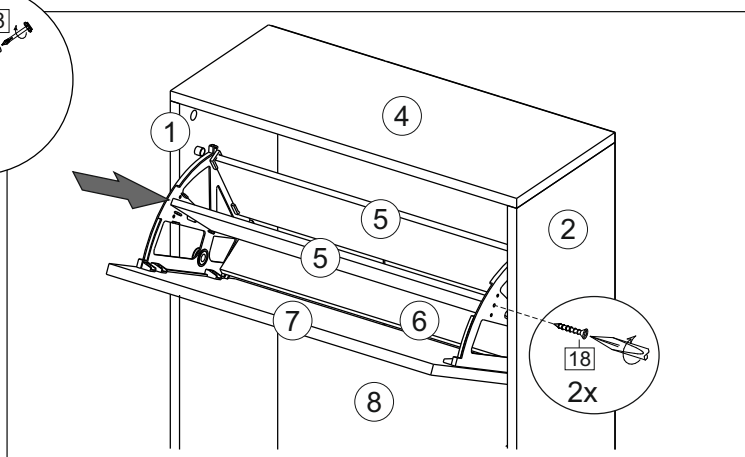
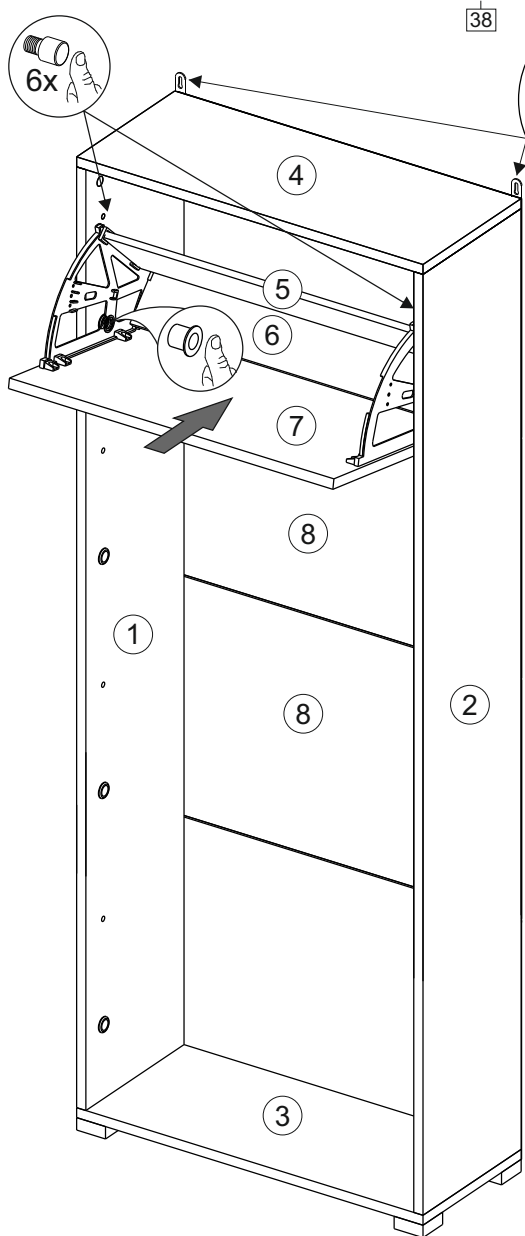
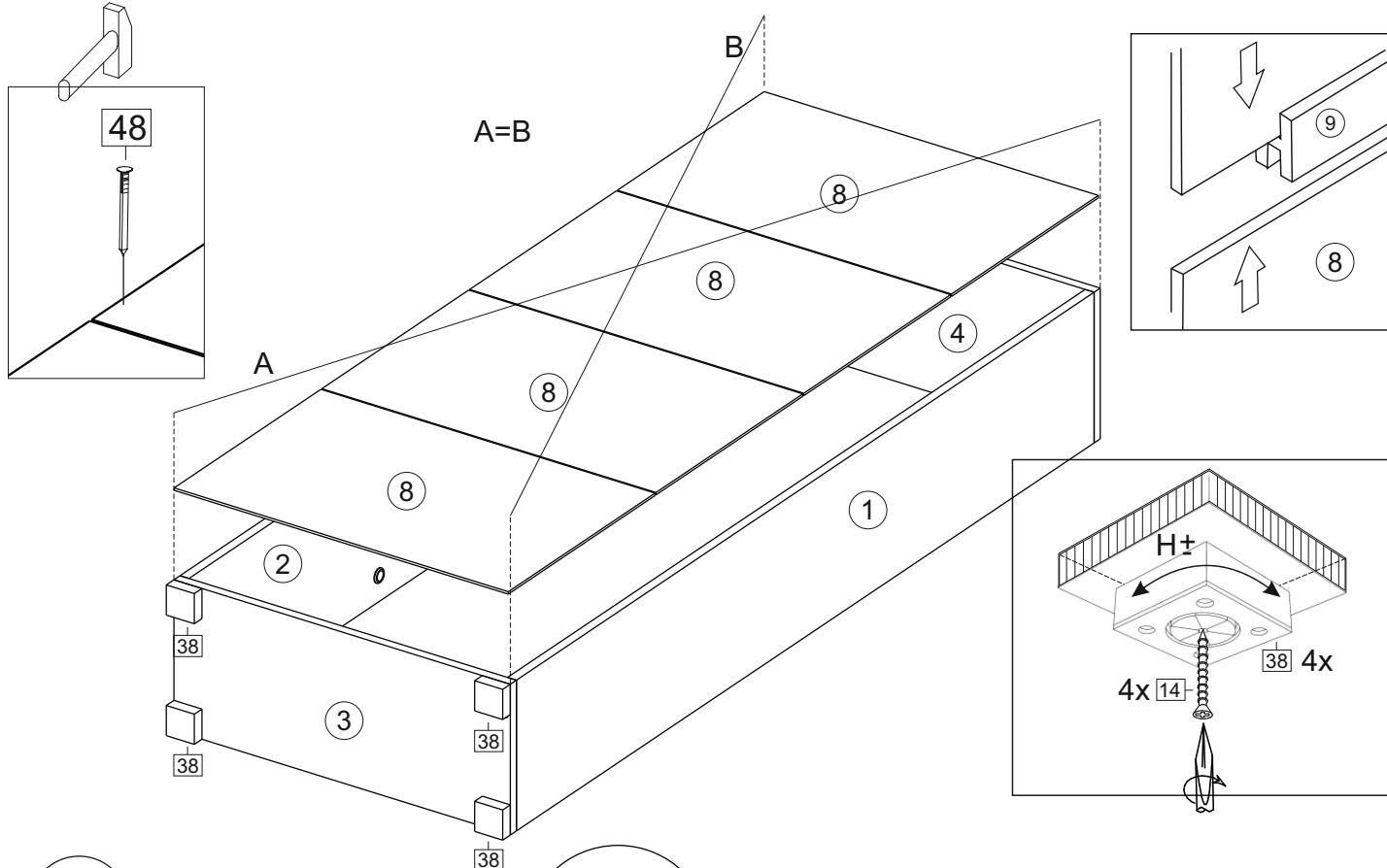

(PL) Instrukcja montażu

(CZ) Návod k montáži

(D) Montageanleitung

(GB) Assembly instruction

(F) Model d'emploi

(HU) Szerelési útmutató

(I) Istruzione di montaggio

(NL) Handleiding voor de montage

(RU) Инструкция по монтажу

(RO) Instrucțiuni de montare

(SK) Návod k montáži

(TR) Montaj talimatı



⚠ Uwaga • Upozornění • Achtung • Attention • Caution • Figyelem • Attenzione • Opgelet • Внимание • Atenție • Upozornenie • Dikkat ⚠

PL	Czyszczenie należy wykonać wyłącznie za pomocą ściereczki lub lekko nawilżonego ręcznika. Nie stosować środków czyszczących do szorowania.
CZ	Čistění je nutné vykonávat výhradně pomocí utěrky nebo lehce navlhčeného ručníku. Nepoužívejte čisticí prostředky obsahující abrazivní částice.
D	Bitte nur mit einem Staubtuch oder leicht feuchtem Lappen reinigen. Keine scheuernden Putzmittel verwenden.
GB	Please only clean with a duster or a damp cloth. Do not use any abrasive cleaners.
F	Le nettoyage se fait uniquement à l'aide d'un torchon ou d'une serviette légèrement mouillée.
HU	A tisztítás kizárólag törölrőruha vagy enyhén nedvesített törölköző segítségével végezhető. Súroló hatású tisztítószereket nem szabad használni.
I	Pulire esclusivamente con un panno o un asciugamano umido.
NL	Reinig alleen met een stofdoek of een lichtjes vochtige doek. Gebruik geen schurende poetsmiddelen.
RU	Очищайте от пыли тряпкой или слегка влажной ветошью. Не допускается применение чистящих средств, не предназначенных для ухода за мебелью.
RO	Curățarea trebuie efectuată numai cu o cârpă sau cu un prosop ușor umezit. Nu utilizați agenți de curățare abrazivi.
SK	Čistení je nutné vykonávať výhradne pomocou utierky alebo ľahko zvlhnutým ručníkom. Nepoužívajte čistiace prostriedky obsahujúce abrazívni častice.
TR	Lütfen sadece bir toz bezilye veya hafif nemli yumuşak bir bezle siliniz. Aşındırıcı temizlik malzemeleri kullanmayınız.



Karta serwisowa • Servisní list • Service Karte • Service card • Carte de service • Szervizkártya • Scheda di servizio • Service kaart • Сервисная карта • Fisa service • Servisný list • Servis karti

